



ALTACOM

/2021
Made in Italy

ALTACOM, IL “FARE” E L’ORIGINALITÀ DEL “MADE IN ITALY”.
ALTACOM, LE “SAVOIR-FAIRE” ET L’ORIGINALITÉ DU “MADE IN ITALY”.
ALTACOM, PRAGMATIC SPIRIT AND THE ORIGINALITY OF THE “MADE IN ITALY”.

Comprendere il movimento, il meccanismo attraverso cui un oggetto può trasformarsi da consolle a tavolo di 3 metri è il frutto di una ricerca costante, di profonde conoscenze tecnico-costruttive ed è alla base di ciascun prodotto Altacom. Se la funzionalità e la semplicità di utilizzo sono determinanti per il successo di un prodotto, altrettanto lo è la capacità “inventiva e interpretativa”: ed è questo che fa la differenza tra un oggetto d’arredo qualunque e quello pensato per voi. Altacom realizza i suoi prodotti per voi, e non per un generico mercato del mobile di complemento: lo fa poiché la sua vocazione è ispirata dal “saper fare” dell’artigiano che sperimenta e produce mettendoci mano, cervello ed elevata tecnologia senza distinzione, facendo nascere da questo connubio le idee migliori, quelle che ci hanno portato ad essere produttori appassionati, partner affidabili, cultori di un design made in Italy applicato alla funzione. Altacom, “versatili” per vocazione.

Comprendre le mouvement, le mécanisme par lequel un objet peut se transformer de simple console à table de repas de 3 mètres est le résultat d’une recherche constante, de profonde connaissance technique-constructive et c’est la base de chaque produit Altacom. Si la fonctionnalité et la facilité d’utilisation sont cruciales pour le succès d’un produit, également on peut dire pour la capacité « inventive et d’interprétation », qui est ce qui fait la différence entre un meuble quelconque et un pensé pour vous. Altacom fabrique ses produits pour vous, et non pour un marché du meuble générique: on le fait parce que notre vocation est inspirée par le « savoir-faire » de l’artisan qui expérimente et produit en y mettant mains, cerveau et technologies à l’avant-garde sans distinction, ce qui fait naître de ce mariage les meilleures idées, celles qui nous ont amenés à être des producteurs passionnés, des partenaires fiables, des amateurs du design italien appliqué à la fonction. Altacom, “versatiles” par vocation.

Understanding the movement, the mechanism through which an object can be transformed from a simple console to a 3 meters’ dining table is the result of constant research, profound technical and constructive knowledge and is the basis of each Altacom product. If functionality and easiness of use are crucial to the success of a product, so is the “inventive and interpretative” ability and this is what makes the difference between any piece of furniture and what is designed for you. Altacom makes its products for you, not for a generic furnishing market: we do so because our vocation is inspired by the “know-how” of the artisan who experiences and produces by putting hands, brain and high technology without distinction, originating from this union the best ideas, the ones having led us to be passionate producers, reliable partners, enthusiasts of a “made in Italy” design applied to the function. Altacom, “versatile” by vocation.

TAVOLI TRASFORMABILI

pg 06

TAVOLI REGOLABILI IN ALTEZZA GRAZIE AD UN MECCANISMO A GAS. PIANO ALLUNGABILE O FISSO, CON ALLUNGHE INTEGRATE O A PARTE.

Tables réglables en hauteur par vérin-gaz. Plateau extensible ou fixe, avec rallonges intégrées ou à part.

Height adjustable tables, with a gas lifting mechanism. Fix or extendable top, with integrated or separate extensions.

CONSOLLE ESTENSIBILI

pg 190

CONSOLLE ALLUNGABILI, CON SISTEMI DI SCORRIMENTO E ALLUNGHE PER IL PIANO

Consoles extensibles, avec mécanique télescopique et rallonges.

Extending console tables, with telescopic mechanism and extensions.

TAVOLI DA PRANZO

pg 262

TAVOLI FISSI O ALLUNGABILI CON DIVERSI SISTEMI DI SCORRIMENTO E ALLUNGHE INTEGRATE O A PARTE.

Tables fixes ou extensibles avec différents systèmes d'ouverture et rallonges intégrées ou à part.

Fix or extendable tables with different opening systems and integrated or separate extensions.

SEDIE

pg 392

SEDIE FISSE O PIEGHEVOLI, IN LEGNO, METALLO E IMBOTTITE.

Chaises fixes ou pliantes, en bois, métal et rembourrées.

Fix or folding chairs, in wood, in metal and upholstered.

TAVOLINI & SGABELLI

pg 402

TAVOLINI E SGABELLI REGOLABILI IN ALTEZZA E COORDINABILI

Tables réglables en hauteur et tabourets coordonnés.

Height adjustable tables and matching stools.

ALTEZZA E LUNGHEZZA VARIABILI

HAUTEUR ET LONGUEUR VARIABLES
VARIABLE HEIGHT AND LENGTH

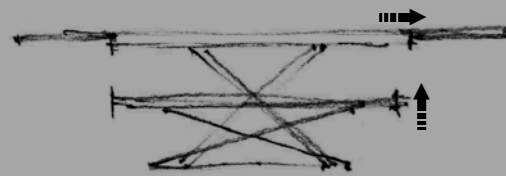

LUNGHEZZA VARIABILE

LONGUEUR VARIABLE
VARIABLE LENGTH

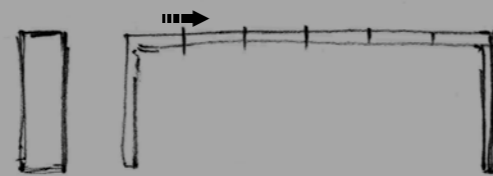

LUNGHEZZA VARIABILE

LONGUEUR VARIABLE
VARIABLE LENGTH

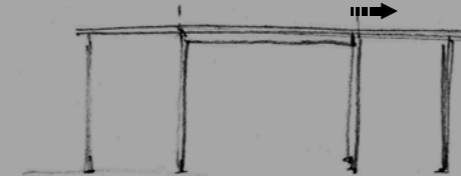

FISSE, PIEGHEVOLI

FIXES, PLIANTES
FIXED, FOLDING



REGOLABILI IN ALTEZZA

REGLABLES EN HAUTEUR
HEIGHT ADJUSTABLE

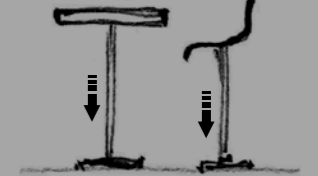

ARES FOLD
ARES GLASS
ARES MEGA
ARES WING
ASSIST
BESSY
CALYPSO
CIAK
COMPACT
DIARIO
DOUBLE
ETOILE
FEBO
FENICE
GENIALE
GINGILLO
HELIOS
ICARO
LEVANTE
LOTUS
SAKURA
TAVOLETTO
ULISSE
UNIVERSE

COMBI
DAVID
DAVINCI
FLAP
GENESI
QUAD
SQUARE
TREK

ARGON
CELSIUS
COMPASSO
FAHRENHEIT
FAHRENHEIT ROUND
GIADA
MERIDIANO
PICK-UP
RIBOT
RIBOT WOOD
SINTESI
SIPARIO
STORM
SUN
TEOREMA
TOWER MAXI
TRINITY

DANDY
ERIKA
HIPPO
JOLIE
JOLIE WOOD
MARIANNA
MOLLY
NANETTE

CENTER/PROFILO
OUTLINE/DROP
ITACA



Made in Italy

INDEX

TAVOLI TRASFORMABILI

HELIOS
pg 08

LEVANTE
pg 16

CALYPSO
pg 24

ULISSE
pg 32

ASSIST
pg 40

FEBO
pg 50

COMPACT
pg 58

DOUBLE
pg 64

ARES FOLD
pg 70

ARES WING
pg 78

ARES GLASS
pg 86

ARES MEGA
pg 94

TAVOLETTO
pg 102

ICARO
pg 112

LOTUS
pg 120

FENICE
pg 128

BESSY
pg 134

CIAK
pg 140

SAKURA
pg 148

UNIVERSE
pg 154

GINGILLO
pg 160

GENIALE
pg 168

ETOILE
pg 174

DIARIO
pg 182

CONSOLLE ESTENSIBILI

GENESI
pg 192

DAVINCI
pg 202

TREK
pg 212

QUAD
pg 220

DAVID
pg 228

SQUARE
pg 238

COMBI
pg 246

FLAP
pg 254

TAVOLI DA PRANZO

SINTESI
pg 264

TRINITY
pg 272

CELSIUS
pg 278

FAHRENHEIT
ROUND
pg 284

SUN
pg 290

GIADA
pg 298

FAHRENHEIT
pg 306

MERIDIANO
pg 314

RIBOT
pg 320

RIBOT WOOD
pg 328

SIPARIO
pg 336

PICK-UP
pg 346

ARGON
pg 354

TEOREMA
pg 362

STORM
pg 370

COMPASSO
pg 376

TOWER MAXI
pg 384

SEDIE

JOLIE
pg 394

JOLIE WOOD
pg 395

NANETTE
pg 396

MARIANNA
pg 397

DANDY
pg 398

MOLLY
pg 399

ERIKA
pg 400

HIPPO
pg 401

TAVOLINI & SGABELLI

CENTER / PROFILO
pg 404

OUTLINE / DROP
pg 408

ITACA
pg 414

MATERIALI

FINITURE
pg 418

TAVOLI TRASFORMABILI

HELIOS
pg 08

LEVANTE
pg 16

CALYPSO
pg 24

ULISSE
pg 32

ASSIST
pg 40

FEBO
pg 50

COMPACT
pg 58

DOUBLE
pg 64

ARES FOLD
pg 70

ARES WING
pg 78

ARES GLASS
pg 86

ARES MEGA
pg 94

TAVOLETTO
pg 102

ICARO
pg 112

LOTUS
pg 120

FENICE
pg 128

BESSY
pg 134

CIAK
pg 140

SAKURA
pg 148

UNIVERSE
pg 154

GINGILLO
pg 160

GENIALE
pg 168

ETOILE
pg 174

DIARIO
pg 182

HELIOS

HELIOS É UN TAVOLO DAL PIANO CIRCOLARE, ESTREMAMENTE VERSATILE NELLE FUNZIONI E NELL'ESTETICA. IL MECCANISMO É OPPORTUNAMENTE STUDIATO PER TRASFORMARSI DA SEDUCENTE TAVOLINO DA SALOTTO A TAVOLO DA PRANZO ALLUNGANDOSI CON ESTREMO COMFORT PER ABITANTI E OSPITI. LA STRUTTURA SOTTOSTANTE IN METALLO SI INCROCIA IN UN PIACEVOLE E SUGGESTIVO GIOCO DI LINEE.

Helios est une table avec un plateau rond, très versatile pour sa fonction et son esthétique. La mécanique est bien conçue pour une séduisante table basse qui se transforme en table de repas, qui s'allonge avec un confort extrême pour tous. La structure en métal en dessous se croise dans un intéressant jeu de lignes.

Helios, with its round top, is an extremely versatile table both in function and in design. The mechanism has been conveniently studied to transform from an alluring coffee table to a dining table, extending with ease for the family and guests. The metal base crossbreeds in a suggestive and pleasant linear visual effect.





HELIOS



HELIOS



FINITURE PIANO FINITIONS PLATEAU TOP FINISHES

NOBILITATO / MÉLAMINE / MELAMINE

N20	Natural halifax oak
N23	Cemento
N24	Ardesia
N25	Vintage chiaro
N30	Morera
N33	Resina silver
N34	Resina grigio cenere
N35	Rovere nodato caramel
N36	Olmo moka
N40	Noce Canaletto
N42	Rovere nero
N43	Bianco spatolato
N44	Bianco statuario venato
N45	Diamond cream
N46	Pietra grey

LEGNO IMPIALLACCIATO / PLACAGE BOIS / VENEER WOOD

W02	Rovere grigio
W03	Rovere tabacco
W04	Rovere nodato
W06	Rovere juta
W07	Rovere fumé
W10	Noce Canaletto

VETRO / VERRE / GLASS

G01	Bianco lucido
G02	Tortora lucido
G03	Nero lucido
G04	Bianco acidato
G05	Tortora acidato
G06	Nero acidato

LACCATO / LAQUÉ / LACQUERED

Poro aperto / Pores ouverts / Open pore

L31	Bianco luce
L32	Bianco panna
L33	Bianco vela
L34	Grigio corda
L35	Grigio canapa
L39	Rosso aragosta
L40	Tortora

CERAMICA / CÉRAMIQUE / CERAMIC

K01	Fokos Sale
K02	Fokos Terra
K03	Fokos Piombo
K04	Noir Desir lucido
K05	Bianco Statuario venato lucido
K06	Diamond Cream lucido
K07	Pietra Grey lucida
K09	Oxide Nero
K10	Oxide Bianco
K11	Pietra Savoia Antracite
K12	Pietra di Savoia Perla
K13	Calacatta Gold lucido
K14	Emperador lucido
K15	Noir Desir opaco
K16	Pietra Grey opaco
K17	Calacatta Gold opaco
K18	Bianco Statuario venato opaco
K19	Diamond Cream opaco
K20	Emperador opaco

EFFETTO MALTA / EFFET-BÉTON / MORTAR-LOOK

E04	Metalli vissuti nichel
E06	Beton tortora
E07	Beton nero
E08	Beton grigio scuro
E09	Beton grigio chiaro
E15	Pietra spatolata travertino metallizzato bianco
E19	Bianco assoluto
E20	Gros carruba
E21	Gros ciocco
E22	Ruggine
E23	Rock silver
E24	Rock copper
E25	Rock cemento

Tavolino trasformabile in tavolo da pranzo, base in metallo, meccanismo a gas, regolabile in altezza al millimetro da cm 36 a cm 75, piano rotondo in nobilitato, legno, vetro, effetto malta e ceramica, prolunga interna a libro. Ruote a scomparsa.

Table relevable en table de repas, piétement en métal, haussement par vérin-gaz, réglable en hauteur au millimètre de cm 36 à cm 75, plateau rond en mélamine, bois, verre, effet-béton et céramique, rallonge intégrée porte-feuille. Roulettes intégrées.

Transforming coffee table, it turns into a dining table. Metal frame, gas lifting device, millimetre-adjustable height from cm 36 to cm 75, melamine, stained wood, glass, mortar-look and ceramic round top, inside folded extension. Under-base wheels.

FINITURE BASE FINITIONS PIÉTEMENT BASE FINISHES

METALLO / MÉTAUX / METALS

M02	Verniciato grisou goffrato
M04	Verniciato nero opaco
M11	Verniciato grafite goffrato
M12	Verniciato tortora opaco
M19	Verniciato bronzo goffrato
M24	Verniciato bianco goffrato

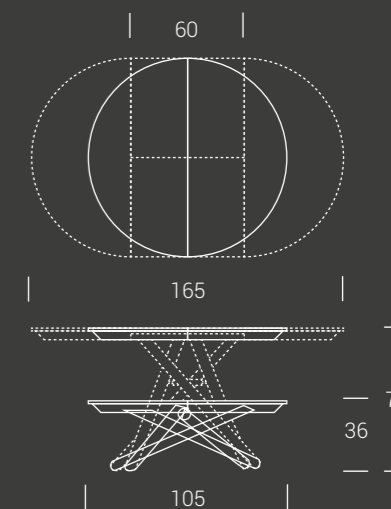

LEVANTE

LEVANTE È UN TAVOLINO TRASFORMABILE CHE INTEGRA LA PARTICOLARITÀ DELLA STRUTTURA METALLICA AD INTRECCIO ALLA SOLIDITÀ DI UN PIANO AD ALTO SPESSORE PROPOSTA IN ROVERE MASSICCIO, UN CONCEPT CHE ABBRACCIA LA MODERNITÀ DELLA FUNZIONE SENZA RINUNCIARE A QUEL RICHIAMO ALLA NATURA COSÌ AMATA DAGLI ESTIMATORI DEL BELLO.

Levante est une table relevable qui combine la particularité de sa structure en métal et la solidité de son plateau épais en chêne vieux. Ce concept embrasse la modernité de la fonction, sans renoncer à l'appel de la nature, si chère à ceux qui aiment la beauté.

Levante is a transforming table that integrates the peculiarity of its bound metal structure with an old oak thick top. This concept embraces the modernity of the function without renouncing to a touch of much appreciated nature.





LEVANTE



LEVANTE



Tavolino trasformabile in tavolo da pranzo, base in metallo, meccanismo a gas, regolabile in altezza al millimetro da cm 36 a cm 75, piano quadrato in nobilitato, legno e effetto malta, due prolunghe interne. Ruote a scomparsa.

Table relevable en table de repas, piétement en métal, haussement par vérin-gaz, réglable en hauteur au millimètre de cm 36 à cm 75, plateau carré en mélamine, bois, effet-béton, deux rallonges internes. Roulettes intégrées.

Transforming coffee table, it turns into a dining table. Metal frame, gas lifting device, millimetre-adjustable height from cm 36 to cm 75, melamine, stained wood, mortar-look square top, two inside extensions. Under-base wheels.

FINITURE PIANO FINITIONS PLATEAU TOP FINISHES

NOBILITATO / MÉLAMINE / MELAMINE

N20	Natural halifax oak
N23	Cemento
N24	Ardesia
N25	Vintage chiaro
N30	Morera
N33	Resina silver
N34	Resina grigio cenere
N35	Rovere nodato caramél
N36	Olmo moka
N40	Noce Canaletto
N42	Rovere nero
N43	Bianco spatolato
N44	Bianco statuario venato
N45	Diamond cream
N46	Pietra grey

LACCATO / LAQUÉ / LACQUERED

Poro aperto / Pores ouverts / Open pore

L31	Bianco luce
L32	Bianco panna
L33	Bianco vela
L34	Grigio corda
L35	Grigio canapa
L39	Rosso aragosta
L40	Tortora

LEGNO IMPIALLACCIATO / PLACAGE BOIS / VENEER WOOD

W02	Rovere grigio
W03	Rovere tabacco
W04	Rovere nodato
W06	Rovere juta
W07	Rovere fumé
W10	Noce Canaletto

LEGNO MASSICCIO / BOIS MASSIF / SOLID WOOD

W21	Rovere vecchio massiccio termotrattato
W32	Rovere vecchio massiccio naturale
W33	Rovere vecchio massiccio grigio

EFFETTO MALTA / EFFET-BÉTON / MORTAR-LOOK

E04	Metalli vissuti nichel
E06	Beton tortora
E07	Beton nero
E08	Beton grigio scuro
E09	Beton grigio chiaro
E15	Pietra spatolata travertino metallizzato bianco
E19	Bianco assoluto
E20	Gros carruba
E21	Gros ciocco
E22	Ruggine
E23	Rock silver
E24	Rock copper
E25	Rock cemento

FINITURE BASE FINITIONS PIÉTEMENT BASE FINISHES

METALLO / MÉTAUX / METALS

M02	Verniciato grisou gofrato
M04	Verniciato nero opaco
M11	Verniciato grafite gofrato
M12	Verniciato tortora opaco
M19	Verniciato bronzo gofrato
M24	Verniciato bianco gofrato

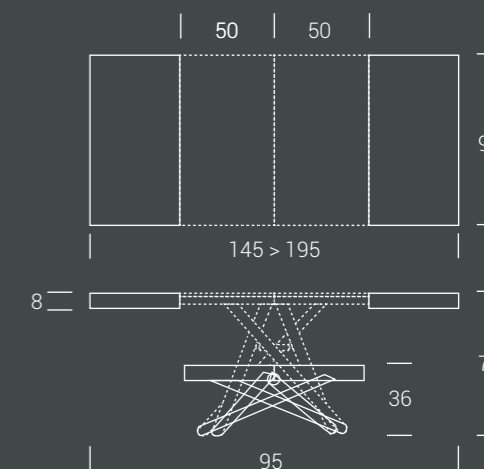

CALYPSO

SEMPRE PRONTO E IN POCHE MOSSE C'È POSTO PER TUTTI. ELEGANZA E QUALITÀ TROVANO IN QUESTO TAVOLO TRASFORMABILE UN CONNUBIO PERFETTO. L'AMPIO SPESSORE DEL PIANO CUSTODISCE GLI ELEMENTI PER ALLUNGARE IL TAVOLO, FINO AL DOPPIO DELLA SUA LUNGHEZZA.

Toujours prête et, en quelques gestes, il y a de la place pour tout le monde. Élégance et qualité se fondent parfaitement dans cette table relevable. Le plateau de forte épaisseur cache les éléments pour agrandir la table, jusqu'au double de sa longueur.

Calypso is always ready and in few moves it can host everyone. Elegance and quality find a perfect match in this transforming table. The thickness of the top guards the elements to extend the table up to the double of its length.

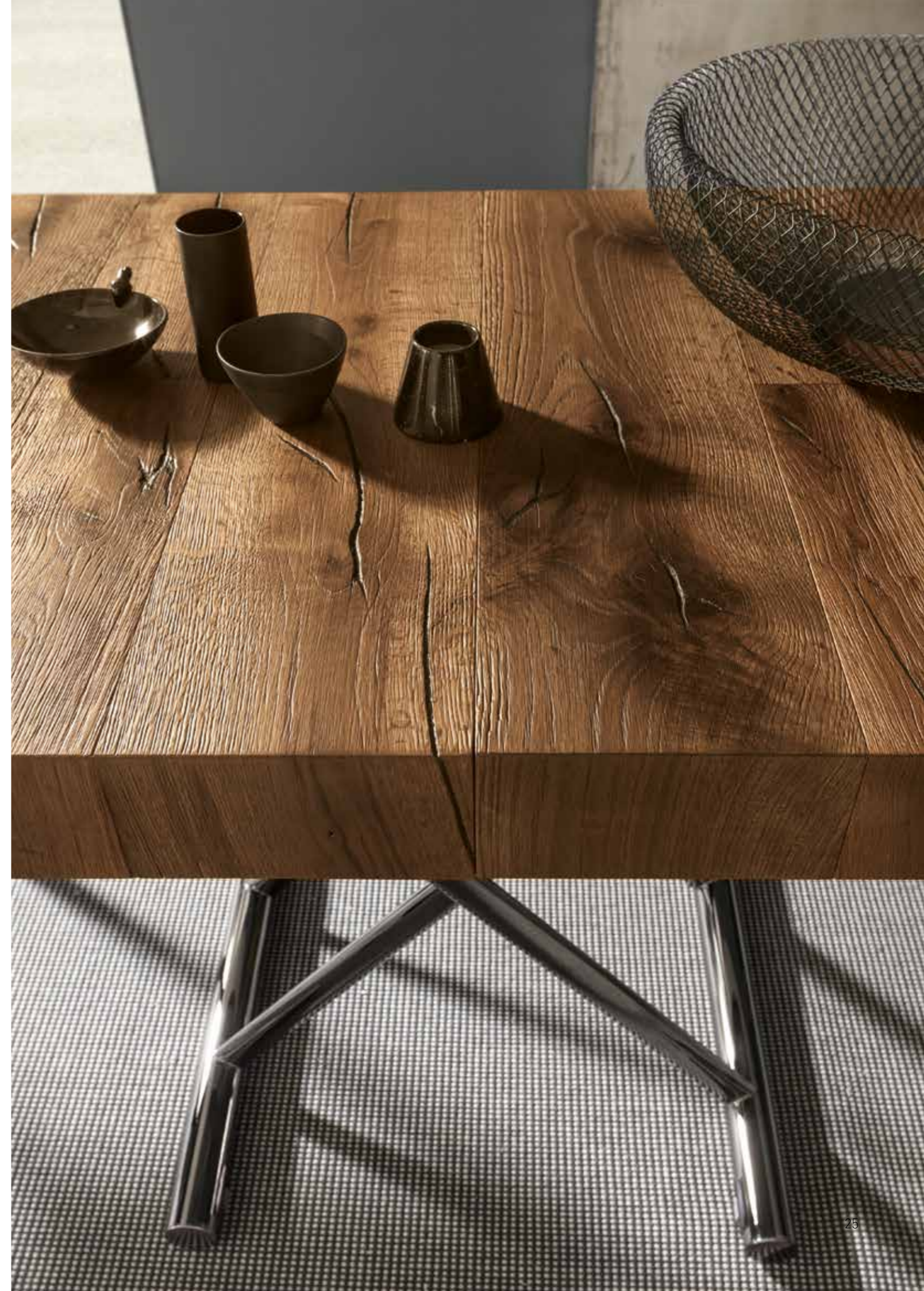

CALYPSO



CALYPSO

DA MOLTO GRANDE A MOLTO PICCOLO: CALYPSO NON DELUDE MAI. REGOLABILE ANCHE IN ALTEZZA RAPPRESENTA UN VALIDO COMPLEMENTO D'ARREDO PER SPAZI DA VIVERE CON STILE.

Dans sa version grande et dans sa version petite, Calypso ne déçoit jamais. Réglable en hauteur également, cette table est un précieux complément pour des espaces à vivre avec style.

From very big to very small Calypso never disappoints. It is adjustable also in height and represents a valid furniture piece for places to live with style.



CALYPSO



FINITURE PIANO FINITIONS PLATEAU TOP FINISHES

NOBILITATO / MÉLAMINE / MELAMINE

N20	Natural halifax oak
N23	Cemento
N24	Ardesia
N25	Vintage chiaro
N30	Morera
N33	Resina silver
N34	Resina grigio cenere
N35	Rovere nodato caramel
N36	Olmo moka
N40	Noce Canaletto
N42	Rovere nero
N43	Bianco spatolato
N44	Bianco statuario venato
N45	Diamond cream
N46	Pietra grey

LACCATO / LAQUÉ / LACQUERED

Poro aperto / Pores ouverts
/ Open pore

L31
L32
L33
L34
L35
L39
L40

Opaco / Mat
/ Matt

L51 Bianco luce
L52 Bianco panna
L53 Bianco vela
L54 Grigio corda
L55 Grigio canapa
L59 Rosso aragosta
L60 Tortora

LEGNO IMPIALLACCIATO / PLACAGE BOIS / VENEER WOOD

W02	Rovere grigio
W03	Rovere tabacco
W04	Rovere nodato
W06	Rovere juta
W07	Rovere fumé
W10	Noce Canaletto

LEGNO MASSICCIO / BOIS MASSIF / SOLID WOOD

W21	Rovere vecchio massiccio termotrattato
W32	Rovere vecchio massiccio naturale
W33	Rovere vecchio massiccio grigio

EFFETTO MALTA / EFFET-BÉTON / MORTAR-LOOK

E04	Metalli vissuti nichel
E06	Beton tortora
E07	Beton nero
E08	Beton grigio scuro
E09	Beton grigio chiaro
E15	Pietra spatolata travertino metallizzato bianco
E19	Bianco assoluto
E20	Gros carruba
E21	Gros ciocco
E22	Ruggine
E23	Rock silver
E24	Rock copper
E25	Rock cemento

Tavolino trasformabile in tavolo da pranzo, base in metallo, meccanismo a gas, regolabile in altezza al millimetro da cm 27 a cm 81, piano rettangolare in nobilitato, laccato, legno o effetto malta, 2 prolunghe interne. Ruote a scomparsa.

Table relevable en table de repas, piétement en acier, haussement par vérin-gaz, réglable en hauteur au millimètre de cm 27 à cm 81, plateau rectangulaire en mélamine, laqué, bois ou effet-béton, 2 rallonges internes. Roulettes intégrées.

Metal frame transforming coffee table, it turns into a dining table, gas lifting device, millimetre-adjustable height from cm 27 to cm 81, melamine, lacquered, wood or mortar-look rectangular top, 2 inside extensions. Under-base wheels.

FINITURE BASE FINITIONS PIÉTEMENT BASE FINISHES

METALLO / MÉTAUX / METALS

M02	Vern. Grisou goffrato
M04	Vern. Nero opaco
M05	Cromo lucido
M09	Cromo nero lucido
M11	Vern. Grafite goffrato
M12	Vern. Tortora opaco
M19	Vern. Bronzo goffrato
M24	Vern. Bianco goffrato

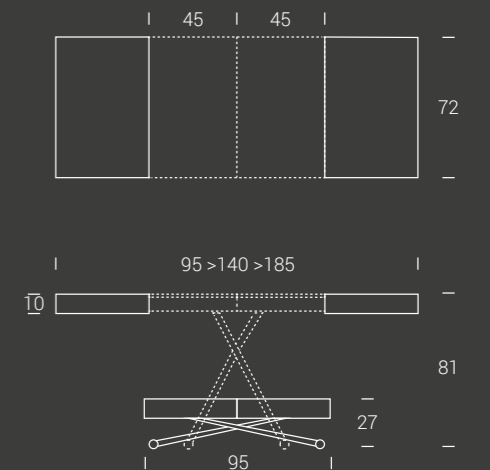

U L I S S E

UN TAVOLINO DALLE LINEE "MINIMAL" CON MECCANISMO A GAS, SI TRASFORMA ALL'OCCORRENZA IN UN TAVOLO DA PRANZO CON SEMPLICI MOVIMENTI DELLA MANO. RAFFINATA LA FINITURA IN NOBILITATO EFFETTO MARMO.

Une table aux lignes « minimales » avec haussement par vérin gaz, se transforme si besoin dans une table de repas avec des gestes simples. Très raffinée la finition melamine effet marbre du plateau.

A table with "minimal" lines and a gas lifting mechanism, it turns, if necessary, into a dining table with a few simple movements. Definitely refined the marble-style melamine finish.





U L I S S E



U L I S S E



Tavolino trasformabile in tavolo da pranzo, base in metallo, meccanismo a gas, regolabile in altezza al millimetro da cm 25 a cm 88, piano rettangolare in nobilitato, laccato, legno, effetto malta, 2 prolunghe interne. Ruote a scomparsa.

Table relevable en table de repas, piétement en acier, haussement par vérin-gaz, réglable en hauteur au millimètre de cm 25 à cm 88, plateau rectangulaire en mélamine, laqué, bois, effet-béton, 2 rallonges internes. Roulettes intégrées.

Transforming coffee table, it turns into a dining table. Metal frame, gas lifting device, millimetre-adjustable height from cm 25 to cm 88, melamine, lacquered, wood, mortar-look rectangular top, 2 inside extensions. Under-base wheels.

FINITURE PIANO FINITIONS PLATEAU TOP FINISHES

NOBILITATO / MÉLAMINE / MELAMINE

N20	Natural halifax oak
N23	Cemento
N24	Ardesia
N25	Vintage chiaro
N30	Morera
N33	Resina silver
N34	Resina grigio cenere
N35	Rovere nodato caramel
N36	Olmo moka
N40	Noce Canaletto
N42	Rovere nero
N43	Bianco spatolato
N44	Bianco statuario venato
N45	Diamond cream
N46	Pietra grey

LACCATO / LAQUÉ / LACQUERED

Poro aperto / Pores ouverts / Open pore	Opaco / Mat / Matt	Lucido / Brilliant / High gloss	
L31	L51	L01	Bianco luce
L32	L52		Bianco panna
L33	L53		Bianco vela
L34	L54		Grigio corda
L35	L55		Grigio canapa
L39	L59		Rosso aragosta
L40	L60		Tortora

LEGNO IMPIALLACCIATO / PLACAGE BOIS / VENEER WOOD

W02	Rovere grigio
W03	Rovere tabacco
W04	Rovere nodato
W06	Rovere juta
W07	Rovere fumé
W10	Noce Canaletto

LEGNO MASSICCIO / BOIS MASSIF / SOLID WOOD

W21	Rovere vecchio massiccio termotrattato
W32	Rovere vecchio massiccio naturale
W33	Rovere vecchio massiccio grigio

EFFETTO MALTA / EFFET-BÉTON / MORTAR-LOOK

E04	Metalli vissuti nichel
E06	Beton tortora
E07	Beton nero
E08	Beton grigio scuro
E09	Beton grigio chiaro
E15	Pietra spatolata travertino metallizzato bianco
E19	Bianco assoluto
E20	Gros carruba
E21	Gros ciocco
E22	Ruggine
E23	Rock silver
E24	Rock copper
E25	Rock cemento

FINITURE BASE FINITIONS PIÉTEMENT BASE FINISHES

METALLO / MÉTAUX / METALS

M02	Verniciato grisou goffrato
M04	Verniciato nero opaco
M05	Cromo lucido
M09	Cromo nero lucido
M11	Verniciato grafite goffrato
M12	Verniciato tortora opaco
M19	Verniciato bronzo goffrato
M24	Verniciato bianco goffrato

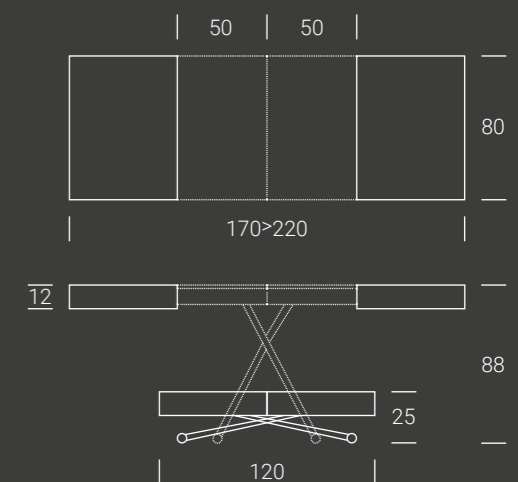

ASSIST

UN TAVOLINO DA SOGGIORNO DALLE PRESTAZIONI STRAORDINARIE, CHE SI TRASFORMA IN UN TAVOLO DA PRANZO CHE PERMETTE DI OSPITARE COMODAMENTE FINO A 14 PERSONE. ASSIST È STATO REALIZZATO PER SODDISFARE LA VOGLIA DI PERSONALIZZARE AL MASSIMO GLI SPAZI DI CASA GIOCANDO CON L'ARREDAMENTO, DIVERTENDOSI.

Des performances extraordinaires pour cette table relevable en table de repas, dont l'extension permet d'accueillir à table jusqu'à 14 personnes en tout confort. Assist permet de personnaliser au maximum les espaces de la maison, en jouant avec le décor, en s'amusant.

A coffee table with extraordinary performance, that turns into a dining table which can host up to 14 people. Assist has been conceived to satisfy the need of fully personalizing the home space by playing with furniture and having fun.











FINITURE PIANO
FINITIONS PLATEAU
TOP FINISHES

NOBILITATO
/ MÉLAMINE
/ MELAMINE

N20	Natural halifax oak
N23	Cemento
N24	Ardesia
N25	Vintage chiaro
N30	Morera
N33	Resina silver
N34	Resina grigio cenere
N35	Rovere nodato caramel
N36	Olmo moka
N40	Noce Canaletto
N42	Rovere nero
N43	Bianco spatolato
N44	Bianco statuario venato
N45	Diamond cream
N46	Pietra grey

LACCATO
/ LAQUÉ
/ LACQUERED

Poro aperto / Pores ouverts / Open pore	Opaco / Mat / Matt	Lucido / Brilliant / High gloss	
L31	L51	L01	Bianco luce
L32	L52		Bianco panna
L33	L53		Bianco vela
L34	L54		Grigio corda
L35	L55		Grigio canapa
L39	L59		Rosso aragosta
L40	L60		Tortora

LEGNO IMPIALLACCIATO
/ PLACAGE BOIS
/ VENEER WOOD

W02	Rovere grigio
W03	Rovere tabacco
W04	Rovere nodato
W06	Rovere juta
W07	Rovere fumé
W10	Noce Canaletto

LEGNO MASSICCIO
/ BOIS MASSIF
/ SOLID WOOD

W21	Rovere vecchio massiccio termotrattato
W32	Rovere vecchio massiccio naturale
W33	Rovere vecchio massiccio grigio

EFFETTO MALTA
/ EFFET-BÉTON
/ MORTAR-LOOK

E04	Metalli vissuti nichel
E06	Beton tortora
E07	Beton nero
E08	Beton grigio scuro
E09	Beton grigio chiaro
E15	Pietra spatolata travertino metallizzato bianco
E19	Bianco assoluto
E20	Gros carruba
E21	Gros ciocco
E22	Ruggine
E23	Rock silver
E24	Rock copper
E25	Rock cemento

Tavolino trasformabile in tavolo da pranzo, base in metallo, meccanismo a gas, regolabile in altezza al millimetro da cm 25 a cm 76, piano rettangolare in nobilitato, laccato, legno, effetto malta, 2 prolunghe interne e 2 prolunghe esterne. Ruote a scomparsa. Gambe pieghevoli di supporto.

Table relevable en table de repas, piétement central en métal, haussement par vérin-gaz, réglable en hauteur au millimètre de cm 25 à cm 76, plateau rectangulaire en mélamine, laqué, bois, effet-béton, 2 rallonges internes et 2 rallonges externes. Roulettes intégrées. Pieds pliables à support des rallonges.

Transforming coffee table, it turns into a dining table. Metal frame, gas lifting device, millimetre-adjustable height from cm 25 to cm 76, melamine, lacquered, stained wood, mortar-look rectangular top, 2 inside extensions and 2 external extensions. Under-base wheels. Supporting folding legs.

FINITURE BASE
FINITIONS PIÉTEMENT
BASE FINISHES

METALLO
/ MÉTAUX
/ METALS

M02	Verniciato grisou gofrato
M04	Verniciato nero opaco
M05	Cromo lucido
M09	Cromo nero lucido
M11	Verniciato grafite gofrato
M12	Verniciato tortora opaco
M19	Verniciato bronzo gofrato
M24	Verniciato bianco gofrato

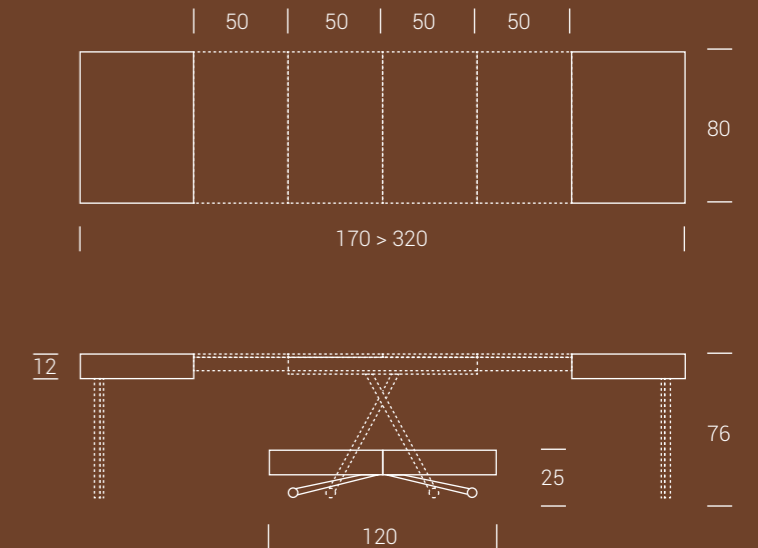

F E B O

DA PICCOLO TAVOLINO DA SALOTTO A GRANDE TAVOLO DA PRANZO. ECCO FEBO, DALLE LINEE ELEGANTI E DAL SAPORE PURO E SOLIDO; SI ADATTA AD OGNI STILE, DA QUELLO PIÙ ESSENZIALE A QUELLO PIÙ RICCO, COMPLETANDO IL DESIGN DI TUTTA LA CASA.

De table basse a table de repas, voici Febo, ces lignes elegantes englobent saveur et solidite, elle s'adapte a chaque style passant par l'essentiel au luxe et s'adapte completement au design de toute la maison.

From small coffee table to a big dining table. Here it goes, Febo, with elegant profiles but with a pure and robust taste; it adapts to every style, from the more essential to the richer one, completing the design of the whole house.









Tavolino trasformabile in tavolo da pranzo, base in metallo, meccanismo a gas regolabile in altezza al millimetro da cm 28 a 80, piano rettangolare in nobilitato, legno o effetto malta. Apertura sincronizzata, con 2 prolunghe a libro. Ruote a scomparsa.

Table relevable en table de repas, piétement en métal, haussement par vérin-gaz, réglable en hauteur au millimètre de cm 28 à cm 80, plateau rectangulaire en mélamine, bois, effet-béton. Ouverture synchronisée avec deux rallonges internes à portefeuille. Roulettes intégrées.

Transforming coffee table, which turns into a dining table. Metal frame, gas lifting mechanism. Millimetre-adjustable height from cm 28 to cm 80, melamine, stained wood, lacquered or mortar-look rectangular top. Synchronized opening mechanisms with two folded extension. Under-base wheels.

FINITURE PIANO
FINITIONS PLATEAU
TOP FINISHES

NOBILITATO
/ MÉLAMINE
/ MELAMINE

- N20 Natural halifax oak
- N23 Cemento
- N24 Ardesia
- N25 Vintage chiaro
- N30 Morera
- N33 Resina silver
- N34 Resina grigio cenere
- N35 Rovere nodato caramel
- N36 Olmo moka
- N40 Noce Canaletto
- N42 Rovere nero
- N43 Bianco spatolato
- N44 Bianco statuario venato
- N45 Diamond cream
- N46 Pietra grey

LACCATO
/ LAQUÉ
/ LACQUERED

Poro aperto / Pores ouverts / Open pore
Opaco / Mat / Matt

- | | | |
|-----|-----|----------------|
| L31 | L51 | Bianco luce |
| L32 | L52 | Bianco panna |
| L33 | L53 | Bianco vela |
| L34 | L54 | Grigio corda |
| L35 | L55 | Grigio canapa |
| L39 | L59 | Rosso aragosta |
| L40 | L60 | Tortora |

LEGNO IMPIALLACCIATO
/ PLACAGE BOIS
/ VENEER WOOD

- W02 Rovere grigio
- W03 Rovere tabacco
- W04 Rovere nodato
- W06 Rovere juta
- W07 Rovere fumé
- W10 Noce Canaletto

LEGNO MASSICCIO
/ BOIS MASSIF
/ SOLID WOOD

- W21 Rovere vecchio massiccio termotrattato
- W32 Rovere vecchio massiccio naturale
- W33 Rovere vecchio massiccio grigio

EFFETTO MALTA
/ EFFET-BÉTON
/ MORTAR-LOOK

- E04 Metalli vissuti nichel
- E06 Beton tortora
- E07 Beton nero
- E08 Beton grigio scuro
- E09 Beton grigio chiaro
- E15 Pietra spatolata travertino metallizzato bianco
- E19 Bianco assoluto
- E20 Gros carruba
- E21 Gros ciocco
- E22 Ruggine
- E23 Rock silver
- E24 Rock copper
- E25 Rock cemento

FINITURE BASE
FINITIONS PIÉTEMENT
BASE FINISHES

METALLO
/ MÉTAUX
/ METALS

- M02 Vern. Grisou goffrato
- M04 Vern. Nero opaco
- M05 Cromo lucido
- M09 Cromo nero lucido
- M11 Vern. Grafite goffrato
- M12 Vern. Tortora opaco
- M19 Vern. Bronzo goffrato
- M24 Vern. Bianco goffrato

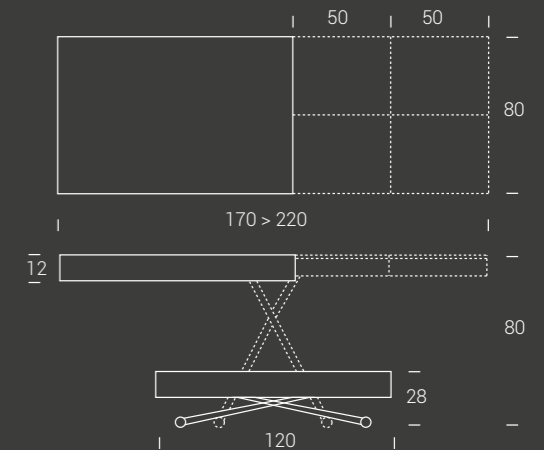

COMPACT

IL SISTEMA DI PROLUNGHE INTERNE A LIBRO CONSENTE DI AMPLIARE IL PIANO D'APPOGGIO SECONDO LE ESIGENZE FUNZIONALI E LO SPAZIO DISPONIBILE. COMPACT, IDEE IN MOVIMENTO.

Le système de rallonges internes à portefeuille permet d'étendre le plateau selon les besoins fonctionnels et l'espace disponible. Compact, des idées en mouvement.

The integrated folding extensions' system enables the top surface to extend following the functional requirements and the space available. Compact, moving ideas.



COMPACT

ESSERE "ALL'ALTEZZA" É UNA DELLE PREROGATIVE DEL TRASFORMABILE COMPACT, UN TAVOLINO COSÌ VERSATILE DA DIVENIRE UN AUTENTICO PASSE-PARTOUT DEL LIVING CONTEMPORANEO, UN'ESTETICA ECLETTICA PER FUNZIONE, ESTREMAMENTE TATTILE NELLE SUPERFICI DEL PIANO.

Être "à la hauteur" est une des caractéristiques de Compact, une table relevable tellement versatile de devenir un authentique passe-partout de l'habitat contemporain, une esthétique éclectique par fonction, extrêmement tactile sur la surface du plateau.

"Measuring up" is one of the peculiarities of Compact, such a versatile transforming table to become an authentic passe-partout of the contemporary living, an eclectic design in function, extremely tactile in the surface of the top.



COMPACT



Tavolino trasformabile in tavolo da pranzo, base in metallo, meccanismo a gas, regolabile in altezza al millimetro da cm 25 a cm 84, piano rettangolare in nobilitato, legno o effetto malta, con 2 prolunghe interne a libro. Ruote a scomparsa.

Table relevable en table de repas, piétement en métal,haussement par vérin-gaz, réglable en hauteur au millimètre de cm 25 à cm 84, plateau rectangulaire en mélamine, bois ou effet-béton, 2 rallonges intégrées à portefeuille. Roulettes intégrées.

Transforming coffee table, it turns into a dining table. Metal frame, gas lifting device, millimetre-adjustable height from cm 25 to cm 84, melamine, stained wood or mortar-look top, 2 inside folded extensions. Under-base wheels.

FINITURE PIANO FINITIONS PLATEAU TOP FINISHES

NOBILITATO / MÉLAMINE / MELAMINE

N20	Natural halifax oak
N23	Cemento
N24	Ardesia
N25	Vintage chiaro
N30	Morera
N33	Resina silver
N34	Resina grigio cenere
N35	Rovere nodato caramel
N36	Olmo moka
N40	Noce Canaletto
N42	Rovere nero
N43	Bianco spatolato
N44	Bianco statuario venato
N45	Diamond cream
N46	Pietra grey

LACCATO / LAQUÉ / LACQUERED

Poro aperto / Pores ouverts / Open pore

L31	Bianco luce
L32	Bianco panna
L33	Bianco vela
L34	Grigio corda
L35	Grigio canapa
L39	Rosso aragosta
L40	Tortora

LEGNO IMPIALLACCIATO / PLACAGE BOIS / VENEER WOOD

W02	Rovere grigio
W03	Rovere tabacco
W04	Rovere nodato
W06	Rovere juta
W07	Rovere fumé
W10	Noce Canaletto

LEGNO MASSICCIO / BOIS MASSIF / SOLID WOOD

W21	Rovere vecchio massiccio termotrattato
W32	Rovere vecchio massiccio naturale
W33	Rovere vecchio massiccio grigio

EFFETTO MALTA / EFFET-BÉTON / MORTAR-LOOK

E04	Metalli vissuti nichel
E06	Beton tortora
E07	Beton nero
E08	Beton grigio scuro
E09	Beton grigio chiaro
E15	Pietra spatolata travertino metallizzato bianco
E19	Bianco assoluto
E20	Gros carruba
E21	Gros ciocco
E22	Ruggine
E23	Rock silver
E24	Rock copper
E25	Rock cemento

FINITURE BASE FINITIONS PIÉTEMENT BASE FINISHES

METALLO / MÉTAUX / METALS

M02	Verniciato grisou goffrato
M04	Verniciato nero opaco
M05	Cromo lucido
M09	Cromo nero lucido
M11	Verniciato grafite goffrato
M12	Verniciato tortora opaco
M19	Verniciato bronzo goffrato
M24	Verniciato bianco goffrato

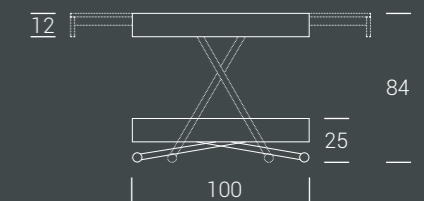
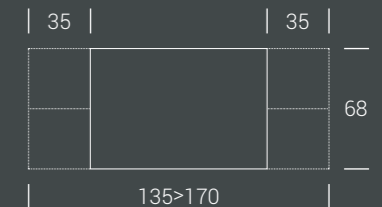

DOUBLE

DOUBLE È IL TAVOLINO TRASFORMABILE CHE SODDISFA DUE RICHIESTE: È IDEALE PER CHI NON AMA IL TAVOLO CON UN'EVIDENTE DIVISIONE A METÀ MA NON VUOLE COMUNQUE RINUNCIARE AL PIANO CASSONATO.

Double est une table relevable qui satisfait deux demandes différentes: la table idéale pour ceux qui n'aiment pas trop le plateau coupé au milieu, sans renoncer au plateau de forte épaisseur.

Double is a transforming table that satisfies two needs: it's perfect for people who don't like to see the top divided in half while maintaining its folded top.



DOUBLE



DOUBLE



Tavolino trasformabile in tavolo da pranzo, base in metallo, meccanismo a gas, regolabile in altezza al millimetro da cm 29 a cm 87, piano rettangolare in nobilitato, laccato, legno o effetto malta, con 2 prolunghe interne a libro. Ruote a scomparsa.

Table relevable en table de repas, piétement en métal, haussement par vérin-gaz, réglable en hauteur au millimètre de cm 29 à cm 87, plateau rectangulaire en mélamine, laqué, bois ou effet-béton, 2 rallonges intégrées à portefeuille. Roulettes intégrées.

Transforming coffee table, it turns into a dining table. Metal frame, gas lifting device, millimetre-adjustable height from cm 29 to cm 87, melamine, lacquered, stained wood or mortar-look top, 2 inside folded extensions. Under-base wheels.

FINITURE PIANO FINITIONS PLATEAU TOP FINISHES

NOBILITATO / MÉLAMINE / MELAMINE

N20	Natural halifax oak
N23	Cemento
N24	Ardesia
N25	Vintage chiaro
N30	Morera
N33	Resina silver
N34	Resina grigio cenere
N35	Rovere nodato caramel
N36	Olmo moka
N40	Noce Canaletto
N42	Rovere nero
N43	Bianco spatolato
N44	Bianco statuario venato
N45	Diamond cream
N46	Pietra grey

LACCATO / LAQUÉ / LACQUERED

Poro aperto / Pores ouverts / Open pore

L31	Bianco luce
L32	Bianco panna
L33	Bianco vela
L34	Grigio corda
L35	Grigio canapa
L39	Rosso aragosta
L40	Tortora

LEGNO IMPIALLACCIATO / PLACAGE BOIS / VENEER WOOD

W02	Rovere grigio
W03	Rovere tabacco
W04	Rovere nodato
W06	Rovere juta
W07	Rovere fumé
W10	Noce Canaletto

LEGNO MASSICCIO / BOIS MASSIF / SOLID WOOD

W21	Rovere vecchio massiccio termotrattato
W32	Rovere vecchio massiccio naturale
W33	Rovere vecchio massiccio grigio

EFFETTO MALTA / EFFET-BÉTON / MORTAR-LOOK

E04	Metalli vissuti nichel
E06	Beton tortora
E07	Beton nero
E08	Beton grigio scuro
E09	Beton grigio chiaro
E15	Pietra spatolata travertino metallizzato bianco
E19	Bianco assoluto
E20	Gros carruba
E21	Gros ciocco
E22	Ruggine
E23	Rock silver
E24	Rock copper
E25	Rock cemento

FINITURE BASE FINITIONS PIÉTEMENT BASE FINISHES

METALLO / MÉTAUX / METALS

M02	Verniciato grisou goffrato
M04	Verniciato nero opaco
M05	Cromo lucido
M09	Cromo nero lucido
M11	Verniciato grafite goffrato
M12	Verniciato tortora opaco
M19	Verniciato bronzo goffrato
M24	Verniciato bianco goffrato

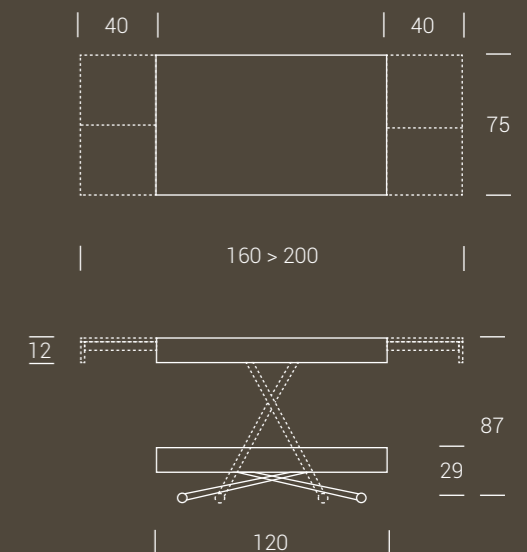

ARES FOLD



MODERNO, FUORI DAL COMUNE, DOTATO DI UN BASAMENTO INSOLITO CHE ATTIRA SUBITO L'ATTENZIONE: ARES FOLD È IL TAVOLINO DA SALOTTO CHE DIVENTA TAVOLO DA PRANZO, PENSATO APPOSTA PER STUPIRE. SI ADATTA FACILMENTE A UN ARREDAMENTO MINIMAL, MA SALTA SUBITO ALL'OCCHIO ANCHE QUANDO È INSERITO IN UNA STANZA PIÙ INFORMALE E VISSUTA.

Moderne, hors de l'ordinaire, avec un piétement qui attire immédiatement l'attention: Ares Fold est une table relevable en table de repas, expressément conçue pour étonner. Cette table s'intègre parfaitement dans un décor minimal et essentiel, mais elle attire l'attention aussi dans un contexte plus informel et chaleureux.

Innovative, out of the box, with an unusual base which immediately catches attention: Ares Fold is a coffee table which transforms into a dining table. It has been thought to amaze. It adapts easily to a minimalist interior design but it immediately stands out even in informal rooms.



Base/Pièment/Base: verniciato grafite gofrato M11
Piano/Plateau/Top: effetto malta metalli vissuti nichel E04



A R E S F O L D



A R E S F O L D
design Altacom

A R E S F O L D



Tavolino trasformabile in tavolo da pranzo, struttura centrale in acciaio, meccanismo a gas, regolabile in altezza al millimetro da cm 41 a cm 82, piano rettangolare nobilitato, laccato, legno, effetto malta, 2 prolunghe interne. Rotelle piroettanti a scomparsa. Brevettato.

Table relevable en table de repas, piétement central en acier, haussement par vérin-gaz, réglable en hauteur au millimètre de cm 41 à cm 82, plateau rectangulaire en mélamine, laqué, bois, effet-béton, 2 rallonges internes. Roulettes cachées sous-piètement. Breveté.

Transforming coffee table which turns into a dining table, steel central column, gas lifting device. Millimetre-adjustable height from cm 41 to cm 82, melamine, lacquered, stained wood, mortar-look rectangular top, 2 inside extensions. Hidden under-plate castors. Patented.

FINITURE PIANO FINITIONS PLATEAU TOP FINISHES

NOBILITATO / MÉLAMINE / MELAMINE

N20	Natural halifax oak
N23	Cemento
N24	Ardesia
N25	Vintage chiaro
N30	Morera
N33	Resina silver
N34	Resina grigio cenere
N35	Rovere nodato caramel
N36	Olmo moka
N40	Noce Canaletto
N42	Rovere nero
N43	Bianco spatolato
N44	Bianco statuario venato
N45	Diamond cream
N46	Pietra grey

LACCATO / LAQUÉ / LACQUERED

Poro aperto / Pores ouverts / Open pore	Opaco / Mat / Matt	Lucido / Brilliant / High gloss	
L31	L51	L01	Bianco luce
L32	L52		Bianco panna
L33	L53		Bianco vela
L34	L54		Grigio corda
L35	L55		Grigio canapa
L39	L59		Rosso aragosta
L40	L60		Tortora

LEGNO IMPIALLACCIATO / PLACAGE BOIS / VENEER WOOD

W02	Rovere grigio
W03	Rovere tabacco
W04	Rovere nodato
W06	Rovere juta
W07	Rovere fumé
W10	Noce Canaletto

LEGNO MASSICCIO / BOIS MASSIF / SOLID WOOD

W21	Rovere vecchio massiccio termotrattato
W32	Rovere vecchio massiccio naturale
W33	Rovere vecchio massiccio grigio

EFFETTO MALTA / EFFET-BÉTON / MORTAR-LOOK

E04	Metalli vissuti nichel
E06	Beton tortora
E07	Beton nero
E08	Beton grigio scuro
E09	Beton grigio chiaro
E15	Pietra spatolata travertino metallizzato bianco
E19	Bianco assoluto
E20	Gros carruba
E21	Gros ciocco
E22	Ruggine
E23	Rock silver
E24	Rock copper
E25	Rock cemento

FINITURE BASE FINITIONS PIÉTEMENT BASE FINISHES

METALLO / MÉTAUX / METALS

M01	Inox
M02	Verniciato grisou goffrato
M04	Verniciato nero opaco
M11	Verniciato grafite goffrato
M12	Verniciato tortora opaco
M19	Verniciato bronzo goffrato
M24	Verniciato bianco goffrato

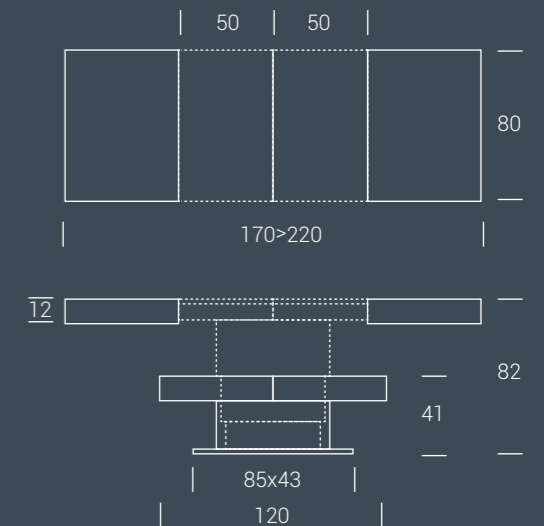

A R E S W I N G

MOVIMENTO RAPIDO, PER CHI AMA LA PRATICITÀ, SENZA MAI RINUNCIARE AL GUSTO: LA VERSIONE DA SOGGIORNO DI ARES WING SI TRASFORMA IN POCHI SECONDI IN UN TAVOLO DA PRANZO MOLTO ELEGANTE E GRADEVOLE. LA SUA ESTREMA DINAMICITÀ LO RENDE SEMPLICEMENTE PERFETTO PER CHI CHIEDE A UN COMPLEMENTO D'ARREDO GRANDE FACILITÀ DI UTILIZZO.

Fonction intelligente et rapide, pour ceux qui aiment la praticité, sans renoncer au goût: Ares Wing se transforme dans quelques secondes en une table de repas belle et élégante. Sa grande fonctionnalité rend cette pièce simplement parfaite pour ceux qui recherchent et veulent la facilité d'utilisation.

Rapid movement, for those who love practicality without renouncing to style: Ares Wing transforms into an elegant dining table in a few seconds. The extreme dynamism makes it perfect for people looking for a user friendly furniture.



A R E S W I N G







Tavolino trasformabile in tavolo da pranzo, struttura centrale in acciaio, meccanismo a gas, regolabile in altezza al millimetro da cm 42 a cm 83, piano rettangolare in nobilitato, laccato, legno o effetto malta, con 2 prolunghe interne a libro coordinate al piano. Rotelle piroettanti a scomparsa. Brevettato.

Table relevable en table de repas, piétement central en acier, haussement par vérin-gaz, réglable en hauteur au millimètre de cm 42 à cm 83, plateau rectangulaire en mélamine, laqué, bois ou effet-béton, avec 2 rallonges intégrées à portefeuille coordonnées au plateau. Roulettes cachées sous-piètement. Breveté.

Transforming coffee table, it turns into a dining table, steel central column, gas lifting device. Millimetre-adjustable height from cm 42 to cm 83, melamine, lacquered, stained wood or mortar-look rectangular top, with 2 inside folded extensions matching top finishing. Hidden under-plate castors. Patented.

FINITURE PIANO
FINITIONS PLATEAU
TOP FINISHES

NOBILITATO
/ MÉLAMINE
/ MELAMINE

- N20 Natural halifax oak
- N23 Cemento
- N24 Ardesia
- N25 Vintage chiaro
- N30 Morera
- N33 Resina silver
- N34 Resina grigio cenere
- N35 Rovere nodato caramel
- N36 Olmo moka
- N40 Noce Canaletto
- N42 Rovere nero
- N43 Bianco spatolato
- N44 Bianco statuario venato
- N45 Diamond cream
- N46 Pietra grey

LACCATO
/ LAQUÉ
/ LACQUERED

- Poro aperto**
/ Pores ouverts
/ Open pore
- L31 Bianco luce
 - L32 Bianco panna
 - L33 Bianco vela
 - L34 Grigio corda
 - L35 Grigio canapa
 - L39 Rosso aragosta
 - L40 Tortora

LEGNO IMPIALLACCIATO
/ PLACAGE BOIS
/ VENEER WOOD

- W02 Rovere grigio
- W03 Rovere tabacco
- W04 Rovere nodato
- W06 Rovere juta
- W07 Rovere fumé
- W10 Noce Canaletto

LEGNO MASSICCIO
/ BOIS MASSIF
/ SOLID WOOD

- W21 Rovere vecchio massiccio termotrattato
- W32 Rovere vecchio massiccio naturale
- W33 Rovere vecchio massiccio grigio

EFFETTO MALTA
/ EFFET-BÉTON
/ MORTAR-LOOK

- E04 Metalli vissuti nichel
- E06 Beton tortora
- E07 Beton nero
- E08 Beton grigio scuro
- E09 Beton grigio chiaro
- E15 Pietra spatolata travertino metallizzato bianco
- E19 Bianco assoluto
- E20 Gros carruba
- E21 Gros ciocco
- E22 Ruggine
- E23 Rock silver
- E24 Rock copper
- E25 Rock cemento

FINITURE BASE
FINITIONS PIÉTEMENT
BASE FINISHES

METALLO
/ MÉTAUX
/ METALS

- M01 Inox
- M02 Verniciato grisou gofrato
- M04 Verniciato nero opaco
- M11 Verniciato grafite gofrato
- M12 Verniciato tortora opaco
- M19 Verniciato bronzo gofrato
- M24 Verniciato bianco gofrato

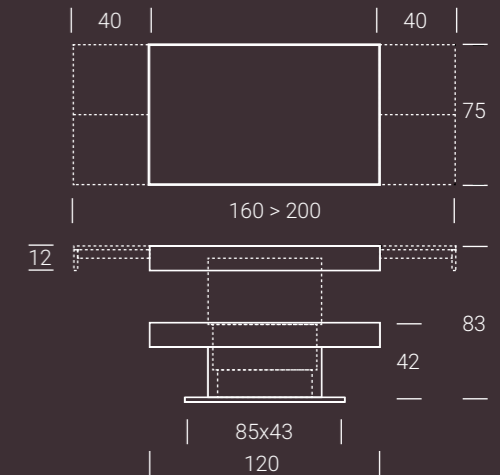

ARES GLASS

UN TAVOLINO CHE RACCHIUDE IN SÉ UNO SPIRITO COSMOPOLITA, UN'ANIMA ANTI-CONFORMISTA E UN MIX DI SFACCETTATURE CHE LO RENDONO STRAORDINARIAMENTE SPECIALE. IL MIX DI MATERIALI DIVERSI E SOLO APPARENTEMENTE IN CONTRASTO, CREA IN REALTÀ UN CONNUBIO PERFETTO. ACCIAIO E VETRO COESISTONO DANDO VITA A UN'ARMONIA UNICA, SOFISTICATA.

Une table qui a un esprit cosmopolite, une âme non conventionnelle et un mix des détails: voilà les particularités qui rendent spéciale cette table. Différents matériaux, qui sont apparemment en contraste, mais qui, au contraire, créent une symbiose parfaite. Acier et verre coexistent, en produisant une harmonie unique et subtile.

A table that embodies a cosmopolitan spirit, a nonconformist soul and a mix of facets which makes it special. The mixing of different materials is just an illusory contrast, that indeed creates a perfect match. Steel and glass coexist in harmony creating a sophisticated atmosphere.





A R E S G L A S S



A R E S G L A S S



Tavolino trasformabile in tavolo da pranzo, struttura centrale in acciaio, meccanismo a gas, regolabile in altezza al millimetro da cm 40 a cm 81, piano in vetro o ceramica, allunghe laterali a libro in nobilitato. Rotelle piroettanti a scomparsa. Brevettato.

Table relevable en table de repas, piétement central en acier, haussement par vérin-gaz, réglable en hauteur au millimètre de cm 40 à cm 81, plateau verre ou céramique, rallonges latérales à portefeuille en mélamine. Roulettes cachées sous-piètement. Breveté.

Transforming coffee table, it turns into a dining table, steel central column, gas lifting device. Millimetre adjustable height from cm 40 to cm 81, glass or ceramic top, side sliding folded extensions in melamine. Hidden under-plate castors. Patented.

FINITURE PIANO FINITIONS PLATEAU TOP FINISHES

VETRO / VERRE / GLASS

- G01 Bianco lucido
- G02 Tortora lucido
- G03 Nero lucido
- G04 Bianco acidato
- G05 Tortora acidato
- G06 Nero acidato

CERAMICA / CÉRAMIQUE / CERAMIC

- K01 Fokos Sale
- K02 Fokos Terra
- K03 Fokos Piombo
- K04 Noir Desir lucido
- K05 Bianco Statuario venato lucido
- K06 Diamond Cream lucido
- K07 Pietra Grey lucida
- K09 Oxide Nero
- K10 Oxide Bianco
- K11 Pietra Savoia Antracite
- K12 Pietra di Savoia Perla
- K13 Calacatta Gold lucido
- K14 Emperador lucido
- K15 Noir Desir opaco
- K16 Pietra Grey opaco
- K17 Calacatta Gold opaco
- K18 Bianco Statuario venato opaco
- K19 Diamond Cream opaco
- K20 Emperador opaco

LAMINAM
SUPERIOR NATURAL SURFACES

FINITURE BASE FINITIONS PIÉTEMENT BASE FINISHES

METALLO / MÉTAUX / METALS

- M01 Inox
- M02 Verniciato grisou goffrato
- M04 Verniciato nero opaco
- M11 Verniciato grafite goffrato
- M12 Verniciato tortora opaco
- M19 Verniciato bronzo goffrato
- M24 Verniciato bianco goffrato

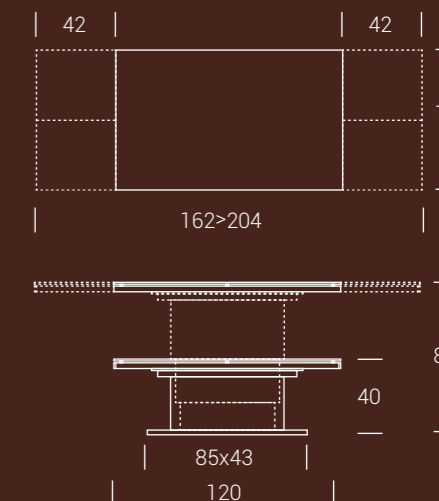

A R E S M E G A

ARES MEGA É IL TRASFORMABILE PER ECCELLENZA, DOTATO DI UNA STRUTTURA CENTRALE IN INOX REGOLABILE IN ALTEZZA SI PRESTA AD ARREDARE L'AREA SALOTTO E LA ZONA PRANZO. IL PIANO AD ALTO SPESSORE, CONTENENTE IL MECCANISMO A GAS, SI INNALZA AL CENTRO STANZA COME UNA SCULTURA MODERNA PER ESSERE APPREZZATA DAL PUBBLICO.

Ares mega est la table relevable par excellence, avec sa structure inox réglable en hauteur, parfaite pour agencer un salon ou une salle à manger. Son plateau, de forte épaisseur cachant une mécanique à vérin gaz, s'élève au milieu de la pièce comme une sculpture moderne à être appréciée par le public.

Ares mega is the transforming table par excellence: with a central height-adjustable inox column it's perfect to furnish both a living and a dining room. Its high thickness top containing the gas lifting mechanism is elevating in the middle of the room as a modern sculpture to be appreciated by the public.



A R E S M E G A



A R E S M E G A





Tavolino trasformabile in tavolo da pranzo, struttura centrale in acciaio, meccanismo a gas, regolabile in altezza da cm 41 a cm 76, piano in nobilitato, laccato, legno, effetto malta, 2 prolunghe interne e 2 prolunghe esterne. Rotelle piroettanti a scomparsa. Gambe pieghevoli di supporto. Brevettato.

Table relevable en table de repas, piétement central en acier, haussement par vérin-gaz, réglable en hauteur au millimètre de cm 41 à cm 76, plateau rectangulaire en mélamine, laqué, bois, effet-béton, 2 rallonges internes plus 2 rallonges à part, pieds pliables à support des rallonges. Roulettes à support des rallonges. Breveté.

Transforming coffee table, it turns into a dining table, steel central column, gas lifting device. Millimetre-adjustable height from cm 41 to cm 76, melamine, lacquered, wood, mortar-look rectangular top, 2 inside extensions and 2 external extensions. Hidden under-plate castors. Supporting folding legs. Patented.

FINITURE PIANO
FINITIONS PLATEAU
TOP FINISHES

NOBILITATO
/ MÉLAMINE
/ MELAMINE

- N20 Natural halifax oak
- N23 Cemento
- N24 Ardesia
- N25 Vintage chiaro
- N30 Morera
- N33 Resina silver
- N34 Resina grigio cenere
- N35 Rovere nodato caramel
- N36 Olmo moka
- N40 Noce Canaletto
- N42 Rovere nero
- N43 Bianco spatolato
- N44 Bianco statuario venato
- N45 Diamond cream
- N46 Pietra grey

LACCATO
/ LAQUÉ
/ LACQUERED

- | Poro aperto
/ Pores ouverts
/ Open pore | Opaco
/ Mat
/ Matt | Lucido
/ Brilliant
/ High gloss | |
|---|--------------------------|---------------------------------------|----------------|
| L31 | L51 | L01 | Bianco luce |
| L32 | L52 | | Bianco panna |
| L33 | L53 | | Bianco vela |
| L34 | L54 | | Grigio corda |
| L35 | L55 | | Grigio canapa |
| L39 | L59 | | Rosso aragosta |
| L40 | L60 | | Tortora |

LEGNO IMPIALLACCIATO
/ PLACAGE BOIS
/ VENEER WOOD

- W02 Rovere grigio
- W03 Rovere tabacco
- W04 Rovere nodato
- W06 Rovere juta
- W07 Rovere fumé
- W10 Noce Canaletto

LEGNO MASSICCIO
/ BOIS MASSIF
/ SOLID WOOD

- W21 Rovere vecchio massiccio termotrattato
- W32 Rovere vecchio massiccio naturale
- W33 Rovere vecchio massiccio grigio

EFFETTO MALTA
/ EFFET-BÉTON
/ MORTAR-LOOK

- E04 Metalli vissuti nichel
- E06 Beton tortora
- E07 Beton nero
- E08 Beton grigio scuro
- E09 Beton grigio chiaro
- E15 Pietra spatolata travertino metallizzato bianco
- E19 Bianco assoluto
- E20 Gros carruba
- E21 Gros ciocco
- E22 Ruggine
- E23 Rock silver
- E24 Rock copper
- E25 Rock cemento

FINITURE BASE
FINITIONS PIÉTEMENT
BASE FINISHES

METALLO
/ MÉTAUX
/ METALS

- M01 Inox
- M02 Verniciato grisou gofrato
- M04 Verniciato nero opaco
- M11 Verniciato grafite gofrato
- M12 Verniciato tortora opaco
- M19 Verniciato bronzo gofrato
- M24 Verniciato bianco gofrato

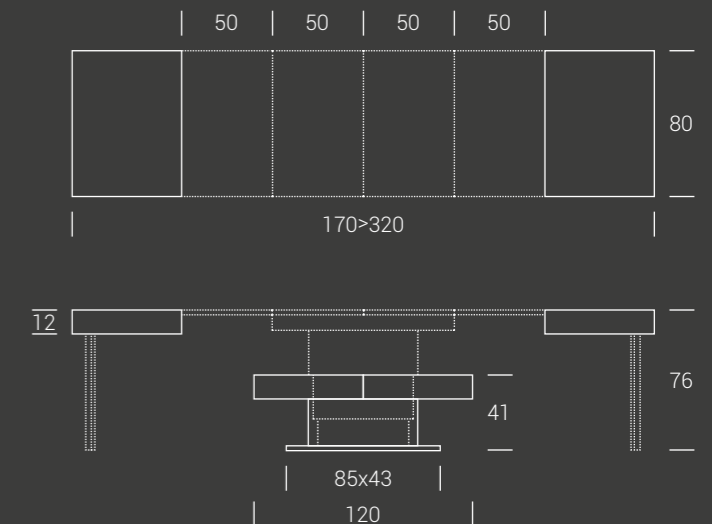

TAVOLETTO

TAVOLETTO RAPPRESENTA L'ASPETTO PIÙ RIVOLUZIONARIO ED ECLETTICO DELL'INTERA GAMMA DI TRASFORMABILI ALTACOM. UN TAVOLINO, REALIZZATO IN ROVERE VECCHIO NATURALE, SI MUOVE IN ALTEZZA PER ASSolverE ALLA FUNZIONE DI TAVOLO DA PRANZO CHE ALL'OCCORRENZA SI EVOLVE DANDO FORMA AD UN COMODO LETTO DI RAFFINATO DESIGN. UN INVITO ALL'OSPITALITÀ E ALLA BELLEZZA DEL MADE IN ITALY.

Tavoletto représente le côté plus révolutionnaire et éclectique de toute la gamme gain-de-place altacom. Une table basse en vrai vieux chêne naturel, qui bouge en hauteur pour devenir une table de repas et qui au besoin évolue pour donner forme à un lit confortable, au design raffiné. Une invitation à l'hospitalité et au charme du made in italy.

Tavoletto represents the most revolutionary and eclectic aspect of the whole range of altacom space-saving. A couch table, made of real old natural oak, moves in height to assolve the dining table function, which evolves, if necessary, into a comfortable bed of refined design. An invitation to hospitality and to the charm of made in italy.



TAVOLETTO



TAVOLETTO

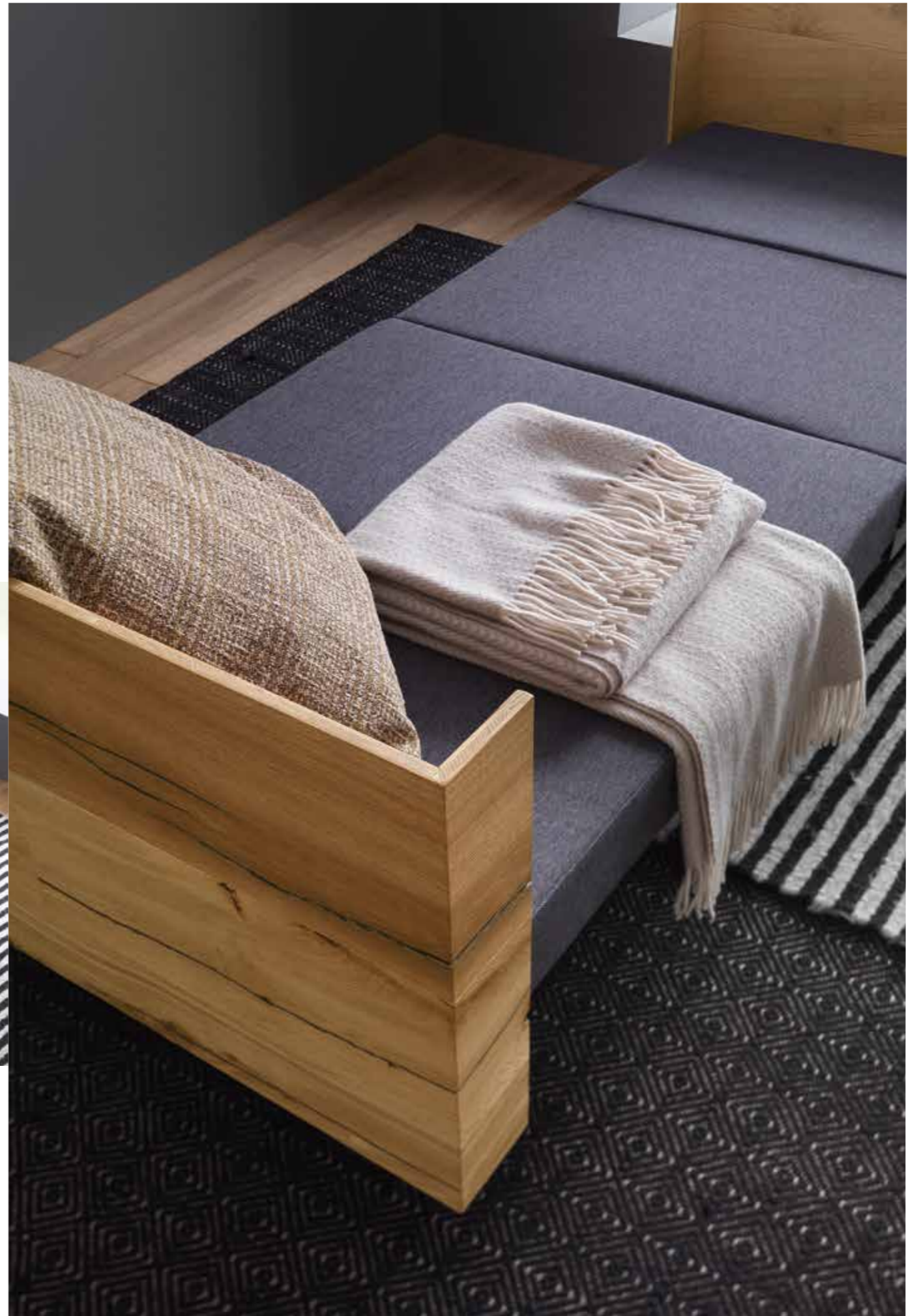

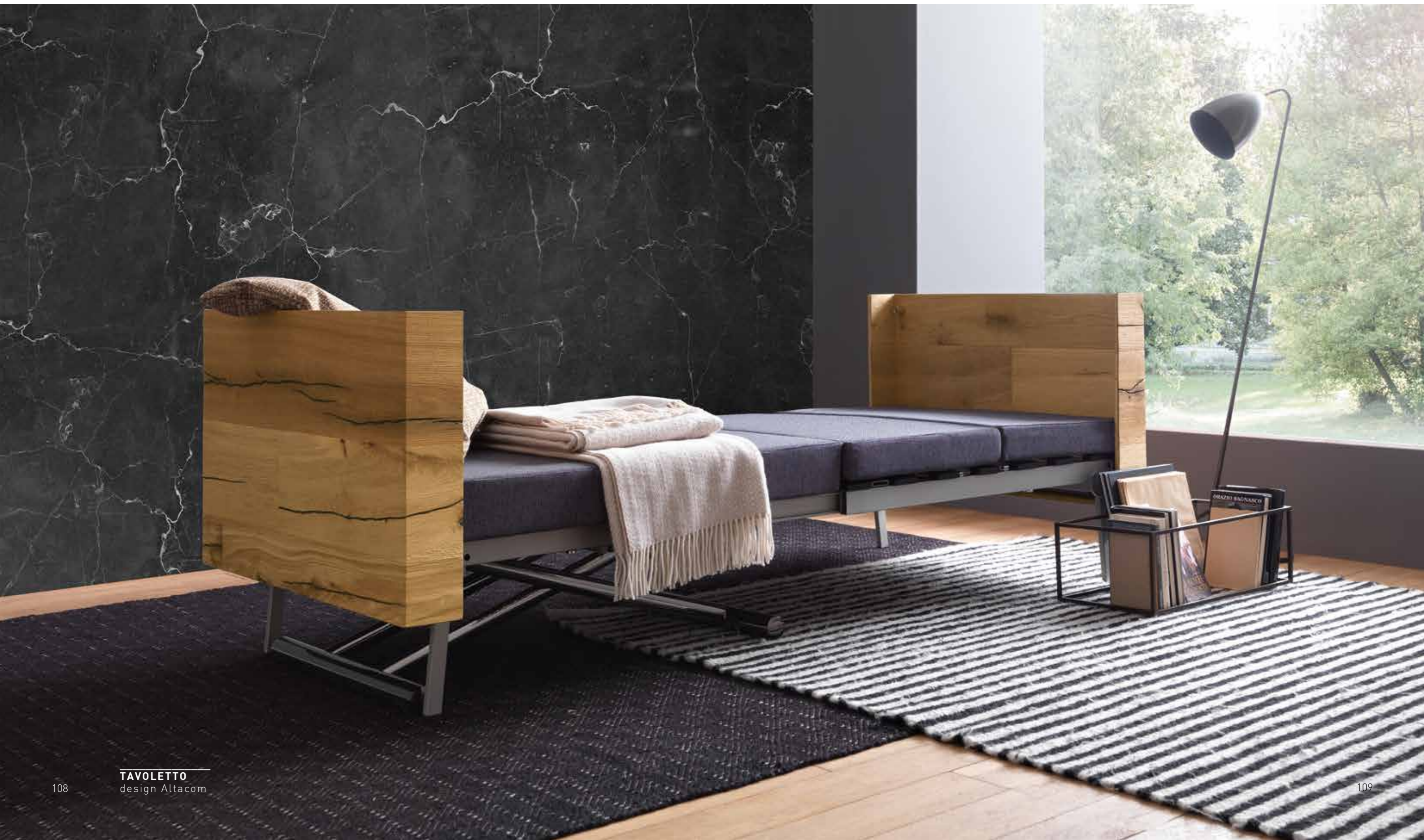

TAVOLETTO



FINITURE PIANO FINITIONS PLATEAU TOP FINISHES

NOBILITATO / MÉLAMINE / MELAMINE

N20	Natural halifax oak
N23	Cemento
N24	Ardesia
N25	Vintage chiaro
N30	Morera
N33	Resina silver
N34	Resina grigio cenere
N35	Rovere nodato caramelo
N36	Olmo moka
N40	Noce Canaletto
N42	Rovere nero
N43	Bianco spatolato
N44	Bianco statuario venato
N45	Diamond cream
N46	Pietra grey

LACCATO / LAQUÉ / LACQUERED

Poro aperto / Pores ouverts / Open pore

L31	Bianco luce
L32	Bianco panna
L33	Bianco vela
L34	Grigio corda
L35	Grigio canapa
L39	Rosso aragosta
L40	Tortora

LEGNO IMPIALLACCIATO / PLACAGE BOIS / VENEER WOOD

W02	Rovere grigio
W03	Rovere tabacco
W04	Rovere nodato
W06	Rovere juta
W07	Rovere fumé
W10	Noce Canaletto

LEGNO MASSICCIO / BOIS MASSIF / SOLID WOOD

W21	Rovere vecchio massiccio termotrattato
W32	Rovere vecchio massiccio naturale
W33	Rovere vecchio massiccio grigio

EFFETTO MALTA / EFFET-BÉTON / MORTAR-LOOK

E04	Metalli vissuti nichel
E06	Beton tortora
E07	Beton nero
E08	Beton grigio scuro
E09	Beton grigio chiaro
E15	Pietra spatolata travertino metallizzato bianco
E19	Bianco assoluto
E20	Gros carruba
E21	Gros ciocco
E22	Ruggine
E23	Rock silver
E24	Rock copper
E25	Rock cemento

Tavolino trasformabile in tavolo da pranzo oppure in letto, base in metallo, meccanismo a gas, regolabile in altezza al millimetro da cm 25 a cm 75, piano rettangolare in nobilitato, legno o effetto malta. Ruote a scomparsa. Dotato di pouff trasformabile in materasso (schiuma poliuretano ignifugo D 35), rivestito in tessuto beige o grigio. Rete a doghe e pannello in legno multistrato. Gambe pieghevoli di supporto.

Table relevable transformable en table de repas ou en lit, piétement en métal,haussement par vérin gaz, réglable en hauteur au millimètre de cm 25 à cm 75, plateau mélamine, bois ou effet-béton. Roulettes intégrées. Avec pouff transformable en matelas (mousse polyuréthane ignifuge D35), revêtu en tissu beige ou gris. Sommier à lattes et panneau en contreplaqué. Pieds pliables à support.

Transforming coffee table, it turns into a dining table or into a bed, metal frame, gas lifting device, millimeter-adjustable height from cm 25 to cm 75, melamine, wood or mortal-look rectangular top. Under-base wheels. Including beige or grey fabric covered pouf, converting to mattress (fire retardant polyurethane foam D35). Bedspring with multilayer slats and panel. Supporting folding legs.

FINITURE BASE FINITIONS PIÉTEMENT BASE FINISHES

METALLO / MÉTAUX / METALS

M02	Verniciato grisou goffrato
M04	Verniciato nero opaco
M05	Cromo lucido
M09	Cromo nero lucido
M11	Verniciato grafite goffrato
M12	Verniciato tortora opaco
M19	Verniciato bronzo goffrato
M24	Verniciato bianco goffrato

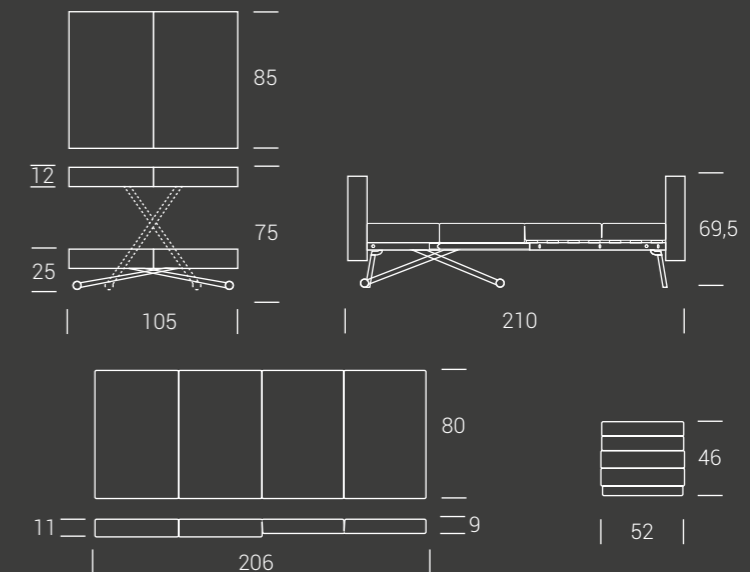

FINITURE POUF/MATERASSO POUF/MATELAS FINITIONS POUF/MATTRESS FINISHES

MATERASSO / MATELAS / MATTRESS

B01	Grigio
B02	Beige

ICARO

NESSUN VOLO PINDARICO, MA UNA PRATICITÀ INGEGNOSA QUELLA PROPOSTA DA ICARO, IL TAVOLO TRASFORMABILE CHE SI PIEGA COME UN ORIGAMI PER LIBERARE O ARREDARE LO SPAZIO SECONDO LE ESIGENZE DEL CASO. UN VERO REGALO PER CHI AMA SOLUZIONI DINAMICHE E CREATIVE NEL PROPRIO SPAZIO ABITATIVO.

Icaro n'implique pas un effort d'imagination, mais une intelligente commodité. Une table relevable qui se plie comme un origami pour meubler ou faire de la place selon ses besoins. Un vrai cadeau pour ceux qui aiment des solutions dynamiques et créatives.

Icaro will bring your expectations beyond imagination with its smart practicality. This table folds like an origami to free or decorate space following any need. A real gift for those who love dynamic and creative solutions in their house.





ICARO



I C A R O



Tavolo pieghevole con apertura a compasso, base in metallo e piano pieghevole in nobilitato. Profondità minima di 8 cm da chiuso, piano tondo diametro 120 cm quando aperto.

Table pliante avec ouverture pivotante, piétement en métal et plateau pliant en mélamine. Profondeur minimale de 8 cm en position fermée, plateau rond diamètre 120 cm en position ouverte.

Folding table with pivotable structure, metal frame and melamine folding top. Minimum depth of 8 cm once closed, round top diameter 120 cm once open.

FINITURE PIANO FINITIONS PLATEAU TOP FINISHES

NOBILITATO / MÉLAMINE / MELAMINE

N20	Natural halifax oak
N23	Cemento
N24	Ardesia
N25	Vintage chiaro
N30	Morera
N33	Resina silver
N34	Resina grigio cenere
N35	Rovere nodato caramel
N36	Olmo moka
N40	Noce Canaletto
N42	Rovere nero
N43	Bianco spatolato
N44	Bianco statuario venato
N45	Diamond cream
N46	Pietra grey

FINITURE BASE FINITIONS PIÉTEMENT BASE FINISHES

METALLO / MÉTAUX / METALS

M02	Verniciato grisou gofrato
M04	Verniciato nero opaco
M11	Verniciato grafite gofrato
M12	Verniciato tortora opaco
M19	Verniciato bronzo gofrato
M24	Verniciato bianco gofrato

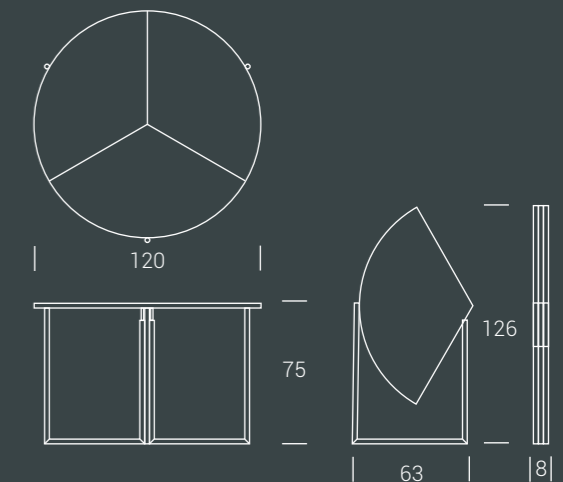

LOTUS

TAVOLO DALLE FORME ESSENZIALI, LOTUS È UN SURROGATO DI PRATICITÀ. INFATTI, CON ESTREMA SEMPLICITÀ, RADDOPPIA LA SUA LARGHEZZA SENZA DOVER AGGIUNGERE ELEMENTI ESTERNI. ANCHE L'ALTEZZA È REGOLABILE A PIACERE IN SVARIATE POSIZIONI. UN TAVOLO, TUTTE LE SOLUZIONI.

Une table aux formes essentielles, Lotus est synonyme de praticité. En effet, en toute simplicité, le plateau se double en largeur, sans devoir recourir à des éléments externes. Même la hauteur est réglable comme on veut, au millimètre. Une table, toutes les solutions.

Lotus, a table with an essential shape, is a substitute for practicality. In fact, it doubles its width with extreme ease without adding external elements. Even its height is adjustable in many positions. One table, all solutions.



LOTUS
design Altacom

Base/Piètement/Base:
verniciato grafite goffrato M11

Piano/Plateau/Top:
nobilitato natural halifax oak N20

LOTUS



LOTUS



LOTUS

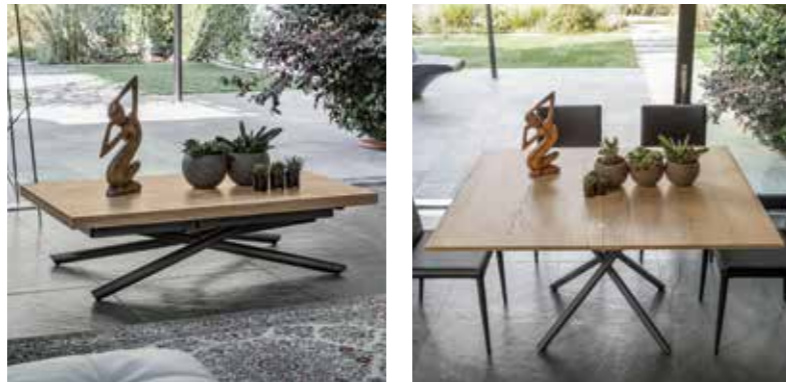

FINITURE PIANO FINITIONS PLATEAU TOP FINISHES

NOBILITATO / MÉLAMINE / MELAMINE

N20	Natural halifax oak
N23	Cemento
N24	Ardesia
N25	Vintage chiaro
N30	Morera
N33	Resina silver
N34	Resina grigio cenere
N35	Rovere nodato caramel
N36	Olmo moka
N40	Noce Canaletto
N42	Rovere nero
N43	Bianco spatolato
N44	Bianco statuario venato
N45	Diamond cream
N46	Pietra grey

CERAMICA OPACA / CÉRAMIQUE MAT / CERAMIC MATT

K01	Fokos Sale
K02	Fokos Terra
K03	Fokos Piombo
K09	Oxide Nero
K10	Oxide Bianco
K11	Pietra Savoia Antracite
K12	Pietra di Savoia Perla
K15	Noir Desir opaco
K16	Pietra Grey opaco
K17	Calacatta Gold opaco
K18	Bianco Statuario venato opaco
K19	Diamond Cream opaco
K20	Emperador opaco

VETRO / VERRE / GLASS

G01	Bianco lucido
G02	Tortora lucido
G03	Nero lucido
G04	Bianco acidato
G05	Tortora acidato
G06	Nero acidato

EFFETTO MALTA / EFFET-BÉTON / MORTAR-LOOK

E04	Metalli vissuti nichel
E06	Beton tortora
E07	Beton nero
E08	Beton grigio scuro
E09	Beton grigio chiaro
E15	Pietra spatolata travertino metallizzato bianco
E19	Bianco assoluto
E20	Gros carruba
E21	Gros ciocco
E22	Ruggine
E23	Rock silver
E24	Rock copper
E25	Rock cemento

Tavolino trasformabile in tavolo da pranzo, base in metallo, meccanismo a gas, regolabile in altezza al millimetro da cm 30 a cm 78, piano raddoppiabile a libro in nobilitato, vetro, effetto malta o ceramica. Ruote a scomparsa.

Table relevable en table de repas, piétement en métal,haussement par vérin-gaz, réglable en hauteur au millimètre de cm 30 à cm 78, plateau portefeuille mélamine, verre, effet-béton ou céramique. Roulettes intégrées.

Metal frame transforming coffee table, it turns into a dining table, gas lifting device, millimetre-adjustable height from cm 30 to cm 78, melamine, glass, mortar-look or ceramic doubling top. Under-base wheels.

FINITURE BASE FINITIONS PIÉTEMENT BASE FINISHES

METALLO / MÉTAUX / METALS

M02	Verniciato grisou gofrato
M04	Verniciato nero opaco
M11	Verniciato grafite gofrato
M12	Verniciato tortora opaco
M19	Verniciato bronzo gofrato
M24	Verniciato bianco gofrato

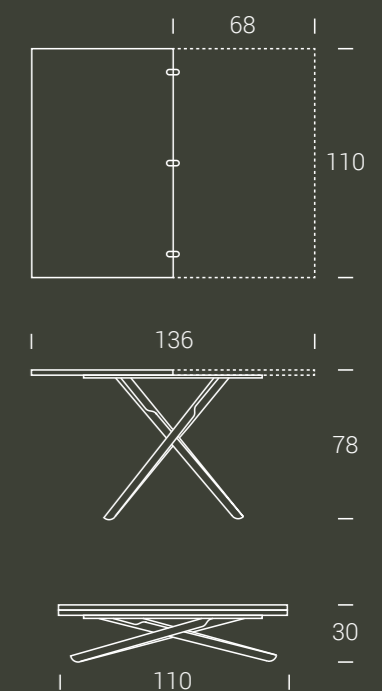

FENICE

UN SOLO TAVOLO DA PRANZO E DA SALOTTO: FENICE È UN TRASFORMABILE CHE COMPLETA L'ARREDAMENTO DELLA ZONA GIORNO, RISOLVENDO CON ELEGANZA OGNI NECESSITÀ. ALTEZZA E LARGHEZZA SONO REGOLABILI A PIACERE IN SVARIATE COMBINAZIONI.

Une table de repas et, en même temps, une table basse: Fenice est un produit relevable qui complète la déco de votre salle de séjour, en répondant aux besoins avec élégance. La hauteur et la largeur sont réglables comme on veut, dans plusieurs combinaisons.

A kitchen and dining table: Fenice is a transforming coffee table that completes the living area furnishing solving all necessities with elegance. Height and width are adjustable in many combinations.



FENICE



F E N I C E



Tavolino trasformabile in tavolo da pranzo, base in metallo, meccanismo a gas, regolabile in altezza al millimetro da cm 22 a cm 77, piano raddoppiabile a libro in nobilitato, vetro, effetto malta o ceramica. Ruote a scomparsa.

Table relevable en table de repas, piétement en métal, haussement par vérin-gaz, réglable en hauteur au millimètre de cm 22 à cm 77, plateau portefeuille mélamine, verre, effet-béton ou céramique. Roulettes intégrées.

Metal frame transforming coffee table, it turns into a dining table, gas lifting device, millimetre-adjustable height from cm 22 to cm 77, melamine, glass, mortar-look or ceramic doubling top. Under-base wheels.

FINITURE PIANO FINITIONS PLATEAU TOP FINISHES

NOBILITATO / MÉLAMINE / MELAMINE

N20	Natural halifax oak
N23	Cemento
N24	Ardesia
N25	Vintage chiaro
N30	Morera
N33	Resina silver
N34	Resina grigio cenere
N35	Rovere nodato caramel
N36	Olmo moka
N40	Noce Canaletto
N42	Rovere nero
N43	Bianco spatolato
N44	Bianco statuario venato
N45	Diamond cream
N46	Pietra grey

CERAMICA OPACA / CÉRAMIQUE MAT / CERAMIC MATT

K01	Fokos Sale
K02	Fokos Terra
K03	Fokos Piombo
K09	Oxide Nero
K10	Oxide Bianco
K11	Pietra Savoia Antracite
K12	Pietra di Savoia Perla
K15	Noir Desir opaco
K16	Pietra Grey opaco
K17	Calacatta Gold opaco
K18	Bianco Statuario venato opaco
K19	Diamond Cream opaco
K20	Emperador opaco

VETRO / VERRE / GLASS

G01	Bianco lucido
G02	Tortora lucido
G03	Nero lucido
G04	Bianco acidato
G05	Tortora acidato
G06	Nero acidato

EFFETTO MALTA / EFFET-BÉTON / MORTAR-LOOK

E04	Metalli vissuti nichel
E06	Beton tortora
E07	Beton nero
E08	Beton grigio scuro
E09	Beton grigio chiaro
E15	Pietra spatolata travertino metallizzato bianco
E19	Bianco assoluto
E20	Gros carruba
E21	Gros ciocco
E22	Ruggine
E23	Rock silver
E24	Rock copper
E25	Rock cemento

FINITURE BASE FINITIONS PIÉTEMENT BASE FINISHES

METALLO / MÉTAUX / METALS

M02	Vern. Grisou gofrato
M04	Vern. Nero opaco
M11	Vern. Grafite gofrato
M12	Vern. Tortora opaco
M19	Vern. Bronzo gofrato
M24	Vern. Bianco gofrato

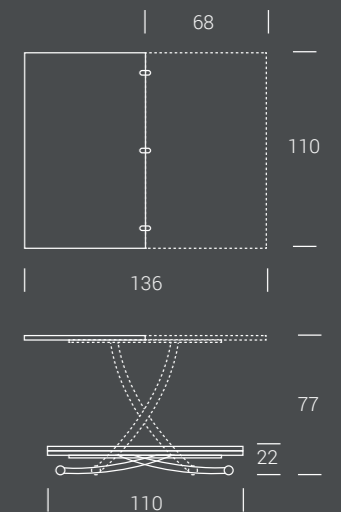

BESSY

SE VI CAPITA SPESSO DI PENSARE CHE AVRESTE PROPRIO BISOGNO DELLO SPAZIO LIBERO OCCUPATO DAL VOSTRO TAVOLINO DA SOGGIORNO, BESSY È CIÒ CHE FA PER VOI. LA FUNZIONE CHE LO RENDE DAVVERO SPECIALE È LA POSSIBILITÀ DI ABBASSARLO FINO A 16 CM, COSÌ DA FARLO SCOMPARIRE FACILMENTE SOTTO LETTI E DIVANI, PER VIVERE AL MASSIMO OGNI CENTIMETRO A DISPOSIZIONE.

Si vous avez besoin de tout l'espace disponible de votre maison, même la place de votre table basse, Bessy est la solution qu'il vous faut, grâce à sa fonction extraordinairement unique: elle se baisse à 16 cm, ce qui permet de la ranger facilement sous un canapé ou un lit. Parfaite pour ceux qui veulent exploiter au maximum chaque centimètre de la maison.

If you often think that you would really need the space occupied by your coffee table, Bessy is the right solution for you. The function that makes it so special is the possibility of reducing its height to cm 16, so that you can easily make it disappear under a bed or a couch. It is the perfect solution for those who want to live every centimeter available in the house.



B E S S Y



BESSY



FINITURE PIANO FINITIONS PLATEAU TOP FINISHES

NOBILITATO / MÉLAMINE / MELAMINE

N20	Natural halifax oak
N23	Cemento
N24	Ardesia
N25	Vintage chiaro
N30	Morera
N33	Resina silver
N34	Resina grigio cenere
N35	Rovere nodato caramel
N36	Olmo moka
N40	Noce Canaletto
N42	Rovere nero
N43	Bianco spatolato
N44	Bianco statuario venato
N45	Diamond cream
N46	Pietra grey

CERAMICA OPACA / CÉRAMIQUE MAT / CERAMIC MATT

K01	Fokos Sale
K02	Fokos Terra
K03	Fokos Piombo
K09	Oxide Nero
K10	Oxide Bianco
K11	Pietra Savoia Antracite
K12	Pietra di Savoia Perla
K15	Noir Desir opaco
K16	Pietra Grey opaco
K17	Calacatta Gold opaco
K18	Bianco Statuario venato opaco
K19	Diamond Cream opaco
K20	Emperador opaco

VETRO / VERRE / GLASS

G01	Bianco lucido
G02	Tortora lucido
G03	Nero lucido
G04	Bianco acidato
G05	Tortora acidato
G06	Nero acidato

EFFETTO MALTA / EFFET-BÉTON / MORTAR-LOOK

E04	Metalli vissuti nichel
E06	Beton tortora
E07	Beton nero
E08	Beton grigio scuro
E09	Beton grigio chiaro
E15	Pietra spatolata travertino metallizzato bianco
E19	Bianco assoluto
E20	Gros carruba
E21	Gros ciocco
E22	Ruggine
E23	Rock silver
E24	Rock copper
E25	Rock cemento

LAMINAM
SUPERIOR NATURAL SURFACES

Tavolino trasformabile in tavolo da pranzo, base in metallo, meccanismo a gas, regolabile in altezza al millimetro da cm 16 a cm 78, piano raddoppiabile a libro in nobilitato, effetto malta, vetro o ceramica. Ruote a scomparsa e rotelle trasversali.

Table relevable en table de repas, piétement en métal, haussement par vérin-gaz, réglable en hauteur au millimètre de cm 16 à cm 78, plateau portefeuille en mélamine, effet-béton, verre ou céramique. Roulettes intégrées et roulettes transversales.

Transforming coffee table which turns into a dining table. Metal frame, gas lifting device, millimetre-adjustable height from cm 16 to cm 78, melamine, glass, mortar-look or ceramic doubling top. Under-base wheels and side translation castors.

FINITURE BASE FINITIONS PIÉTEMENT BASE FINISHES

METALLO / MÉTAUX / METALS

M02	Verniciato grisou goffrato
M04	Verniciato nero opaco
M05	Cromo lucido
M09	Cromo nero lucido
M11	Verniciato grafite goffrato
M12	Verniciato tortora opaco
M19	Verniciato bronzo goffrato
M24	Verniciato bianco goffrato

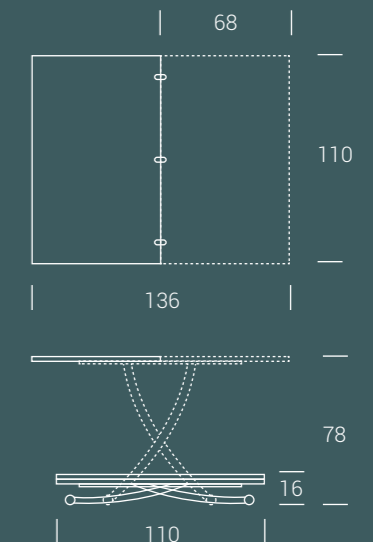

C I A K

PER CHI CERCA UN TAVOLO SEMPLICE E POCO IMPEGNATIVO, CHE FA IL SUO DOVERE NELLA VITA DI TUTTI I GIORNI: CIAK È IL TAVOLO DALLO STILE "EASY", CONCRETO, PER CHI NON AMA I FRONZOLI E ADORA LA FUNZIONALITÀ DI UN TAVOLINO TRASFORMABILE DA VIVERE AL MASSIMO, SENZA PAURA DI SCIUPARLO.

Pour ceux qui veulent une table simple et fonctionnelle, une table qui fait son devoir au quotidien: Ciak est la table au style facile et concret, pour ceux qui aiment le caractère pratique d'une table relevable à vivre au maximum, sans la peur de la gâcher.

This table is an easy going solution to exploit in the everyday routine. Ciak has an easy and pragmatic style that is best suited for people who don't like frills but are more attentive to function and the possibility of exploiting the table at most without ruining it.









FINITURE PIANO
FINITIONS PLATEAU
TOP FINISHES

NOBILITATO
/ MÉLAMINE
/ MELAMINE

- N20 Natural halifax oak
- N23 Cemento
- N24 Ardesia
- N25 Vintage chiaro
- N30 Morera
- N33 Resina silver
- N34 Resina grigio cenere
- N35 Rovere nodato caramel
- N36 Olmo moka
- N40 Noce Canaletto
- N42 Rovere nero
- N43 Bianco spatolato
- N44 Bianco statuario venato
- N45 Diamond cream
- N46 Pietra grey

CERAMICA OPACA
/ CÉRAMIQUE MAT
/ CERAMIC MATT

- K01 Fokos Sale
- K02 Fokos Terra
- K03 Fokos Piombo
- K09 Oxide Nero
- K10 Oxide Bianco
- K11 Pietra Savoia Antracite
- K12 Pietra di Savoia Perla
- K15 Noir Desir opaco
- K16 Pietra Grey opaco
- K17 Calacatta Gold opaco
- K18 Bianco Statuario venato opaco
- K19 Diamond Cream opaco
- K20 Emperador opaco

VETRO
/ VERRE
/ GLASS

- G01 Bianco lucido
- G02 Tortora lucido
- G03 Nero lucido
- G04 Bianco acidato
- G05 Tortora acidato
- G06 Nero acidato

EFFETTO MALTA
/ EFFET-BÉTON
/ MORTAR-LOOK

- E04 Metalli vissuti nichel
- E06 Beton tortora
- E07 Beton nero
- E08 Beton grigio scuro
- E09 Beton grigio chiaro
- E15 Pietra spatolata travertino metallizzato bianco
- E19 Bianco assoluto
- E20 Gros carruba
- E21 Gros ciocco
- E22 Ruggine
- E23 Rock silver
- E24 Rock copper
- E25 Rock cemento

Tavolino trasformabile in tavolo da pranzo, base in metallo, meccanismo a gas regolabile in altezza al millimetro da cm 25 a cm 76, piano raddoppiabile a libro in nobilitato, vetro, effetto-malta o ceramica. Ruote a scomparsa.

Table relevable en table de repas, piétement en métal, réglage en hauteur par vérin-gaz, réglable en hauteur au millimètre de cm 25 à cm 76, plateau portefeuille en mélamine, verre, effet-béton ou ceramique. Roulettes intégrées.

Metal frame transforming coffee table, it turns into a dining table, gas lifting device, millimetre-adjustable height from cm 25 to cm 76, melamine, glass, mortar-look or ceramic doubling top. Under-base wheels.

FINITURE BASE
FINITIONS PIÉTEMENT
BASE FINISHES

METALLO
/ MÉTAUX
/ METALS

- M02 Verniciato grisou goffrato
- M04 Verniciato nero opaco
- M05 Cromo lucido
- M09 Cromo nero lucido
- M11 Verniciato grafite goffrato
- M12 Verniciato tortora opaco
- M19 Verniciato bronzo goffrato
- M24 Verniciato bianco goffrato

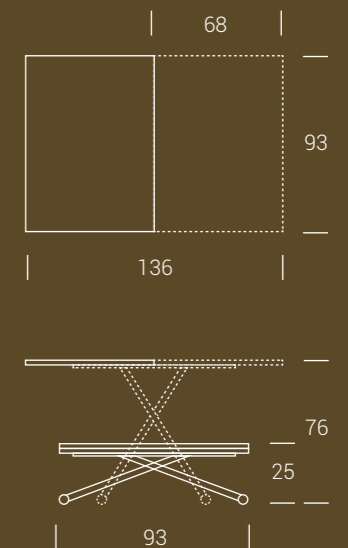

SAKURA

CON LE SUE FORME MORBIDE E SINUOSE, SAKURA PRENDE ISPIRAZIONE DAL FIORE DI CILIEGIO, CERCANDO DI RICREARNE LA DELICATEZZA E LA BELLEZZA. IL RISULTATO È UN TAVOLINO FUNZIONALE CHE RADDOPPIA IL SUO PIANO IN LARGHEZZA E CHE ALLO STESSO TEMPO VANTA UN'ESTETICA ESTREMAMENTE RAFFINATA, PER CHI RICERCA QUEL PIZZICO DI DESIGN IN PIÙ.

Avec ses lignes sinueuses, douces et raffinées, Sakura s'inspire de la fleur de cerisier, d'où la table hérite le nom japonais, en essayant d'imiter sa délicatesse et beauté. Le résultat est cette table avec le plateau portefeuille, fonctionnelle, au goût léger, pour une touche d'élégance dans le décor.

With its sinuous, soft and delicate shapes, Sakura is inspired by the cherry blossom, from which it inherits the name and whose beauty and refinement try to replicate. The result is a functional table that doubles its size in width and at the same time maintains a refined style, for those who want a more polished design.



SAKURA



SAKURA



Tavolino trasformabile in tavolo da pranzo, base in metallo, meccanismo a gas, regolabile in altezza al millimetro da cm 35 a cm 75, piano raddoppiabile a libro in nobilitato, effetto malta, vetro o ceramica.

piétement en métal, haussement par vérin-gaz, réglable en hauteur au millimètre de cm 35 à cm 75, plateau portefeuille en mélamine, effet-béton, verre ou céramique.

a dining table. Metal frame, gas lifting device, millimetre-adjustable height from cm 35 to cm 75, melamine, glass, mortar-look or ceramic doubling top.

Table relevable en table de repas,

Transforming coffee table, it turns into

FINITURE PIANO FINITIONS PLATEAU TOP FINISHES

NOBILITATO / MÉLAMINE / MELAMINE

N20	Natural halifax oak
N23	Cemento
N24	Ardesia
N25	Vintage chiaro
N30	Morera
N33	Resina silver
N34	Resina grigio cenere
N35	Rovere nodato caramel
N36	Olmo moka
N40	Noce Canaletto
N42	Rovere nero
N43	Bianco spatolato
N44	Bianco statuario venato
N45	Diamond cream
N46	Pietra grey

CERAMICA OPACA / CÉRAMIQUE MAT / CERAMIC MATT

K01	Fokos Sale
K02	Fokos Terra
K03	Fokos Piombo
K09	Oxide Nero
K10	Oxide Bianco
K11	Pietra Savoia Antracite
K12	Pietra di Savoia Perla
K15	Noir Desir opaco
K16	Pietra Grey opaco
K17	Calacatta Gold opaco
K18	Bianco Statuario venato opaco
K19	Diamond Cream opaco
K20	Emperador opaco

VETRO / VERRE / GLASS

G01	Bianco lucido
G02	Tortora lucido
G03	Nero lucido
G04	Bianco acidato
G05	Tortora acidato
G06	Nero acidato

EFFETTO MALTA / EFFET-BÉTON / MORTAR-LOOK

E04	Metalli vissuti nichel
E06	Beton tortora
E07	Beton nero
E08	Beton grigio scuro
E09	Beton grigio chiaro
E15	Pietra spatolata travertino metallizzato bianco
E19	Bianco assoluto
E20	Gros carruba
E21	Gros ciocco
E22	Ruggine
E23	Rock silver
E24	Rock copper
E25	Rock cemento

FINITURE BASE FINITIONS PIÉTEMENT BASE FINISHES

METALLO / MÉTAUX / METALS

M02	Verniciato grisou goffrato
M04	Verniciato nero opaco
M11	Verniciato grafite goffrato
M12	Verniciato tortora opaco
M19	Verniciato bronzo goffrato
M24	Verniciato bianco goffrato

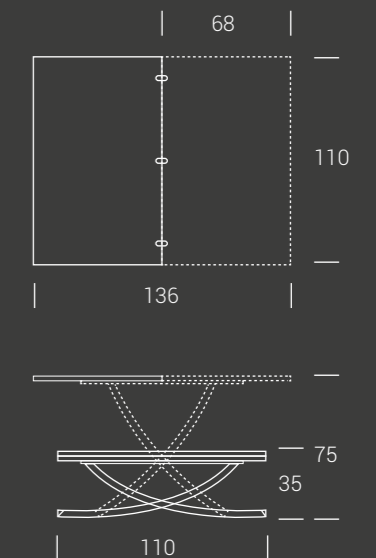

UNIVERSE

IL NOME DI QUESTO TAVOLO PREANNUNCIA LA SUA QUALITÀ MIGLIORE: L'UNIVERSALITÀ, LA CAPACITÀ DI ADATTARSI A STILI, GUSTI ED ESIGENZE DIFFERENTI. UNIVERSE È UN VERO EVERGREEN, RAFFINATO COME TAVOLINO DA SOGGIORNO E PRATICISSIMO TAVOLO DA PRANZO.

Déjà dans son nom l'on identifie sa meilleure qualité: l'universalité, la capacité d'adaptation aux styles, aux goûts et aux besoins différents. Universe est un objet intemporel, table basse très élégante et table de repas très pratique.

The name of this table lets us know in advance its best quality: universality, the capability of adapting to every style, taste, and need. Universe is an evergreen model, a refined coffee table and a practical dining table.



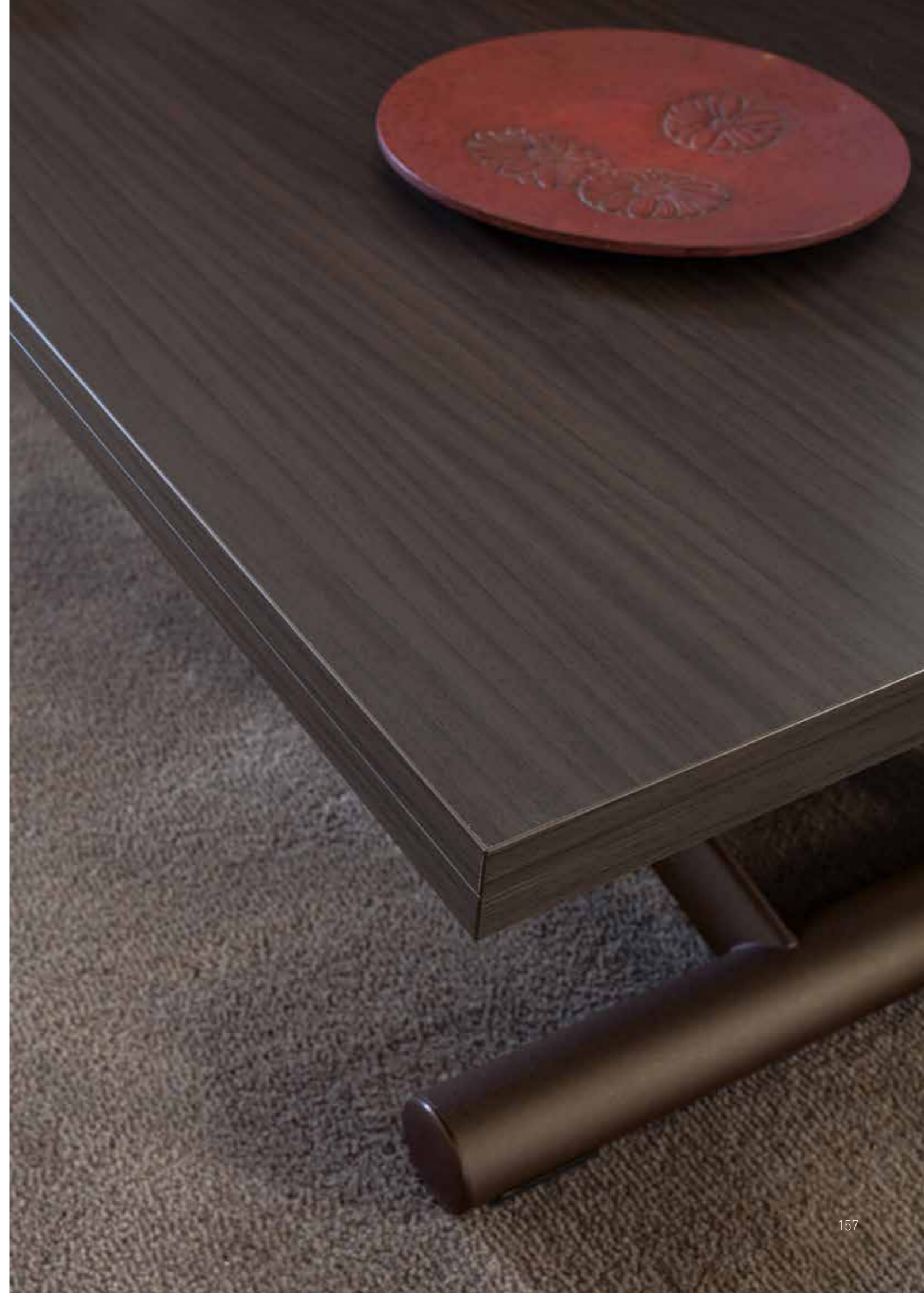



Tavolino trasformabile in tavolo da pranzo, base in metallo, meccanismo a gas, regolabile in altezza al millimetro da cm 27 a cm 81, piano raddoppiabile a libro in nobilitato, effetto malta, vetro o ceramica. Ruote a scomparsa.

Table relevable en table de repas, piétement en métal, haussement par vérin-gaz, réglable en hauteur au millimètre de cm 27 à cm 81, plateau portefeuille mélamine, effet-béton, verre ou céramique. Roulettes intégrées.

Transforming coffee table, it turns into a dining table. Metal frame, gas lifting device, millimetre-adjustable height from cm 27 to cm 81, melamine, glass, mortar-look, or ceramic doubling top. Under-base wheels.

FINITURE PIANO
FINITIONS PLATEAU
TOP FINISHES

NOBILITATO
/ MÉLAMINE
/ MELAMINE

- N20 Natural halifax oak
- N23 Cemento
- N24 Ardesia
- N25 Vintage chiaro
- N30 Morera
- N33 Resina silver
- N34 Resina grigio cenere
- N35 Rovere nodato caramel
- N36 Olmo moka
- N40 Noce Canaletto
- N42 Rovere nero
- N43 Bianco spatolato
- N44 Bianco statuario venato
- N45 Diamond cream
- N46 Pietra grey

CERAMICA OPACA
/ CÉRAMIQUE MAT
/ CERAMIC MATT

- K01 Fokos Sale
- K02 Fokos Terra
- K03 Fokos Piombo
- K09 Oxide Nero
- K10 Oxide Bianco
- K11 Pietra Savoia Antracite
- K12 Pietra di Savoia Perla
- K15 Noir Desir opaco
- K16 Pietra Grey opaco
- K17 Calacatta Gold opaco
- K18 Bianco Statuario venato opaco
- K19 Diamond Cream opaco
- K20 Emperador opaco

VETRO
/ VERRE
/ GLASS

- G01 Bianco lucido
- G02 Tortora lucido
- G03 Nero lucido
- G04 Bianco acidato
- G05 Tortora acidato
- G06 Nero acidato

EFFETTO MALTA
/ EFFET-BÉTON
/ MORTAR-LOOK

- E04 Metalli vissuti nichel
- E06 Beton tortora
- E07 Beton nero
- E08 Beton grigio scuro
- E09 Beton grigio chiaro
- E15 Pietra spatolata travertino metallizzato bianco
- E19 Bianco assoluto
- E20 Gros carruba
- E21 Gros ciocco
- E22 Ruggine
- E23 Rock silver
- E24 Rock copper
- E25 Rock cemento

FINITURE BASE
FINITIONS PIÉTEMENT
BASE FINISHES

METALLO
/ MÉTAUX
/ METALS

- M02 Verniciato grisou goffrato
- M04 Verniciato nero opaco
- M05 Cromo lucido
- M09 Cromo nero lucido
- M11 Verniciato grafite goffrato
- M12 Verniciato tortora opaco
- M19 Verniciato bronzo goffrato
- M24 Verniciato bianco goffrato

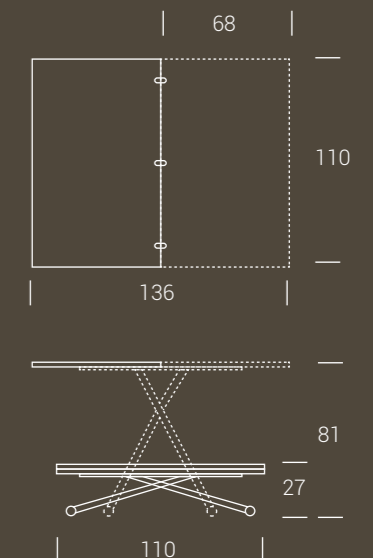

GINGILLO

GINGILLO È UNA VERA CHICCA. UN TAVOLINO DI DIMENSIONI DISCRETE, UN DESIGN SEMPLICE E LA FACILITÀ DI UTILIZZO CHE NON DELUDE: IN SOLE DUE MOSSE RADDOPPIA LA SUA LUNGHEZZA. L'ESSENZIALITÀ DI GINGILLO È CIÒ CHE CI VUOLE QUANDO NATURALITÀ E GENUINITÀ SONO I VALORI IN CUI CREDIAMO E CHE DESIDERIAMO ESPRIMERE ATTRAVERSO L'ARREDAMENTO CHE SCEGLIAMO.

Gingillo est vraiment exceptionnelle. Une table aux dimensions limitées, un design simple, la praticité de la fonction: avec seulement deux gestes le plateau se double en longueur. L'essentialité de Gingillo est le bon choix, si on recherche la naturalité et l'authenticité dans le décor choisi.

Gingillo is a real gem. A table with moderate dimensions, simple design and easy of use: it doubles its length in only two moves. With its concision we want to express the values of naturalness and genuineness in which we believe and that we express through our choice of furniture.

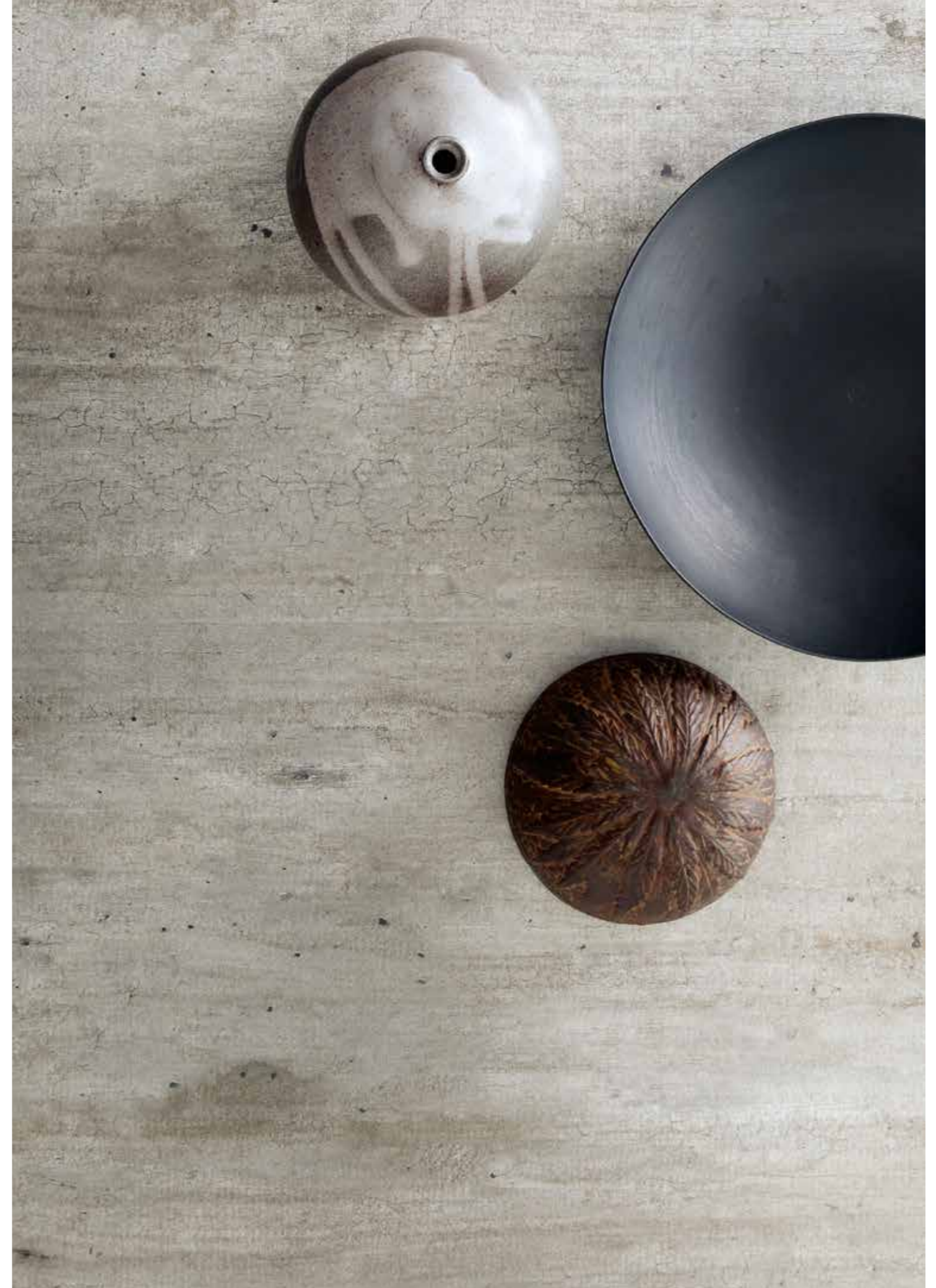





GINGILLO



Tavolino trasformabile in tavolo da pranzo, base in metallo, meccanismo a gas, regolabile in altezza al millimetro da cm 25 a cm 78, piano a libro raddoppiabile in lunghezza in nobilitato, effetto malta, vetro o ceramica.
Ruote a scomparsa.

Table relevable en table de repas, piétement en métal, haussement par vérin-gaz, réglable en hauteur au millimètre de cm 25 à cm 78, plateau portefeuille doublant en longueur en mélamine, effet-béton, verre ou céramique. Roulettes intégrées.

Transforming coffee table, it turns into a dining table, metal frame, gas lifting device, millimetre-adjustable height from cm 25 to cm 78, melamine, glass, mortar-look or ceramic doubling in length top. Under base wheels.

FINITURE PIANO
FINITIONS PLATEAU
TOP FINISHES

NOBILITATO
/ MÉLAMINE
/ MELAMINE

- N20 Natural halifax oak
- N23 Cemento
- N24 Ardesia
- N25 Vintage chiaro
- N30 Morera
- N33 Resina silver
- N34 Resina grigio cenere
- N35 Rovere nodato caramel
- N36 Olmo moka
- N40 Noce Canaletto
- N42 Rovere nero
- N43 Bianco spatolato
- N44 Bianco statuario venato
- N45 Diamond cream
- N46 Pietra grey

CERAMICA OPACA
/ CÉRAMIQUE MAT
/ CERAMIC MATT

- K01 Fokos Sale
- K02 Fokos Terra
- K03 Fokos Piombo
- K09 Oxide Nero
- K10 Oxide Bianco
- K11 Pietra Savoia Antracite
- K12 Pietra di Savoia Perla
- K15 Noir Desir opaco
- K16 Pietra Grey opaco
- K17 Calacatta Gold opaco
- K18 Bianco Statuario venato opaco
- K19 Diamond Cream opaco
- K20 Emperador opaco

VETRO
/ VERRE
/ GLASS

- G01 Bianco lucido
- G02 Tortora lucido
- G03 Nero lucido
- G04 Bianco acidato
- G05 Tortora acidato
- G06 Nero acidato

EFFETTO MALTA
/ EFFET-BÉTON
/ MORTAR-LOOK

- E04 Metalli vissuti nichel
- E06 Beton tortora
- E07 Beton nero
- E08 Beton grigio scuro
- E09 Beton grigio chiaro
- E15 Pietra spatolata travertino metallizzato bianco
- E19 Bianco assoluto
- E20 Gros carruba
- E21 Gros ciocco
- E22 Ruggine
- E23 Rock silver
- E24 Rock copper
- E25 Rock cemento

FINITURE BASE
FINITIONS PIÉTEMENT
BASE FINISHES

METALLO
/ MÉTAUX
/ METALS

- M02 Verniciato grisou goffrato
- M04 Verniciato nero opaco
- M05 Cromo lucido
- M09 Cromo nero lucido
- M11 Verniciato grafite goffrato
- M12 Verniciato tortora opaco
- M19 Verniciato bronzo goffrato
- M24 Verniciato bianco goffrato

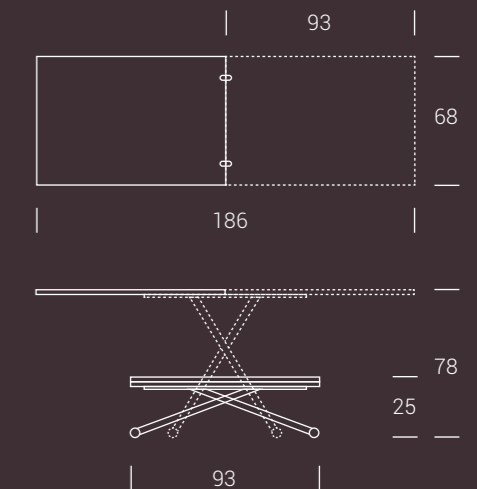

GENIALE

IL TAVOLINO TRASFORMABILE PIÙ BASSO AL MONDO È GENIALE, DI NOME E DI FATTO. QUANDO È BASSO PUÒ FACILMENTE SCOMPARIRE SOTTO UN LETTO O UN DIVANO, PER GUADAGNARE ULTERIORE SPAZIO IN SOGGIORNO, MENTRE QUANDO È ALTO È UNA COMODA POSTAZIONE DOVE POTER LAVORARE O PRANZARE. UN TAVOLO DAVVERO INTELLIGENTE.

La table relevable plus basse au monde, déjà dans son nom l'on identifie sa qualité principale. Si elle est toute basse, elle peut être placée sous un lit ou un canapé, au fin de gagner de la place dans le salon; si elle est toute haute, elle est une table de repas ou une table de travail très confortable. Une table vraiment...Géniale.

The lowest transforming table is Geniale. When in its lowest position, it can easily disappear under a bed or a couch, to gain even more space in the living room. When in its highest position, it's a solid workstation or dining table. A very smart solution.



GENIALE



GENIALE

GENIALE, NELLA SUA POSIZIONE PIÙ BASSA PUÒ SCOMPARIRE SOTTO UN LETTO O UN DIVANO, PER GUADAGNARE ULTERIORE SPAZIO!

EN POSITION BASSE LA GENIALE PEUT ÊTRE DISPARAÎTRE SOUS UN LIT OU UN CANAPÉ, POUR GAGNER DE LA PLACE SUPPLÉMENTAIRE.

GENIALE, IN ITS LOWER POSITION CAN DISAPPEAR UNDER A BED OR A COUCH, TO GAIN EVEN MORE SPACE!



FINITURE PIANO FINITIONS PLATEAU TOP FINISHES

NOBILITATO / MÉLAMINE / MELAMINE

N20	Natural halifax oak
N23	Cemento
N24	Ardesia
N25	Vintage chiaro
N30	Morera
N33	Resina silver
N34	Resina grigio cenere
N35	Rovere nodato caramelo
N36	Olmo moka
N40	Noce Canaletto
N42	Rovere nero
N43	Bianco spatolato
N44	Bianco statuario venato
N45	Diamond cream
N46	Pietra grey

**Tavolino trasformabile
in tavolo da pranzo, base
in metallo, meccanismo a
gas regolabile in altezza al
millimetro da cm 11
a cm 75,5, piano in nobilitato.
Ruote a scomparsa e rotelle
trasversali.**

Table relevable en table de repas, piétement en métal, réglage en hauteur par vérin-gaz, réglable en hauteur au millimètre de cm 11 à cm 75,5, plateau en mélamine. Roulettes intégrées et roulettes transversales.

Transforming coffee table, it turns into a dining table. Metal frame, gas lifting device, millimetre-adjustable height from cm 11 to cm 75.5, melamine. Under-base wheels and side translation castors.

FINITURE BASE FINITIONS PIÉTEMENT BASE FINISHES

METALLO / MÉTAUX / METALS

M02	Verniciato grisou goffrato
M04	Verniciato nero opaco
M05	Cromo lucido
M09	Cromo nero lucido
M11	Verniciato grafite goffrato
M12	Verniciato tortora opaco
M19	Verniciato bronzo goffrato
M24	Verniciato bianco goffrato

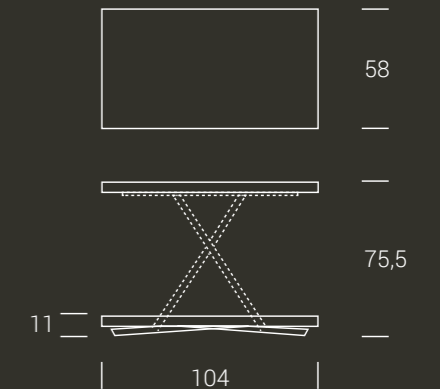

ETOILE

ETOILE RICORDA LA DELICATEZZA, LA RAFFINATEZZA E LA GRAZIA DI UN BALLERINO CHE SI MUOVE SINUOSAMENTE. CON IL SUO PIANO IN CRISTALLO O CERAMICA È SINONIMO DI MODERNITÀ ED È L'IDEALE PER CHI VUOLE AGGIUNGERE UN PIZZICO DI PREZIOSA ELEGANZA IN SOGGIORNO. FUNZIONALITÀ, PRATICITÀ E FINEZZA RACCHIUSE IN SOLO TAVOLO.

Etoile rappelle la délicatesse, l'élégance et la grâce d'un bon danseur. Son plateau en verre ou céramique est synonyme de modernité et cette table est l'idéal pour ceux qui veulent ajouter une touche d'élégance dans le salon. Fonctionnalité, praticité et finesse dans un seul produit.

Etoile reminds the delicacy, refinement and grace of a dancer moving sinuously. Its glass or ceramic top is synonym of modernity and it is the ideal solution for people looking for elegance. Functionality, practicality and delicacy are embedded in one table.





ETOILE



ETOILE



FINITURE PIANO FINITIONS PLATEAU TOP FINISHES

VETRO / VERRE / GLASS

- G01 Bianco lucido
- G02 Tortora lucido
- G03 Nero lucido
- G04 Bianco acidato
- G05 Tortora acidato
- G06 Nero acidato

CERAMICA / CÉRAMIQUE / CERAMIC

- K01 Fokos Sale
- K02 Fokos Terra
- K03 Fokos Piombo
- K04 Noir Desir lucido
- K05 Bianco Statuario venato lucido
- K06 Diamond Cream lucido
- K07 Pietra Grey lucida
- K09 Oxide Nero
- K10 Oxide Bianco
- K11 Pietra Savoia Antracite
- K12 Pietra di Savoia Perla
- K13 Calacatta Gold lucido
- K14 Emperador lucido
- K15 Noir Desir opaco
- K16 Pietra Grey opaco
- K17 Calacatta Gold opaco
- K18 Bianco Statuario venato opaco
- K19 Diamond Cream opaco
- K20 Emperador opaco

LAMINAM
SUPERIOR NATURAL SURFACES

Tavolino trasformabile in tavolo da pranzo, base in metallo, meccanismo a gas, regolabile in altezza al millimetro da cm 27 a cm 86, piano in vetro o ceramica, allunghe laterali a libro in nobilitato. Ruote a scomparsa.

Table relevable en table de repas, piétement en métal, haussement par vérin-gaz, réglable en hauteur au millimètre de cm 27 à cm 86, plateau verre ou céramique, rallonges latérales à portefeuille en mélamine. Roulettes intégrées.

Transforming coffee table, it turns into a dining table. Metal frame, gas lifting device, millimetre-adjustable height from cm 27 to cm 86, glass or ceramic top, 2 side sliding folded extensions in melamine. Under-base wheels.

FINITURE BASE FINITIONS PIÉTEMENT BASE FINISHES

METALLO / MÉTAUX / METALS

- M02 Verniciato grisou gofrato
- M04 Verniciato nero opaco
- M05 Cromo lucido
- M09 Cromo nero lucido
- M11 Verniciato grafite gofrato
- M12 Verniciato tortora opaco
- M19 Verniciato bronzo gofrato
- M24 Verniciato bianco gofrato

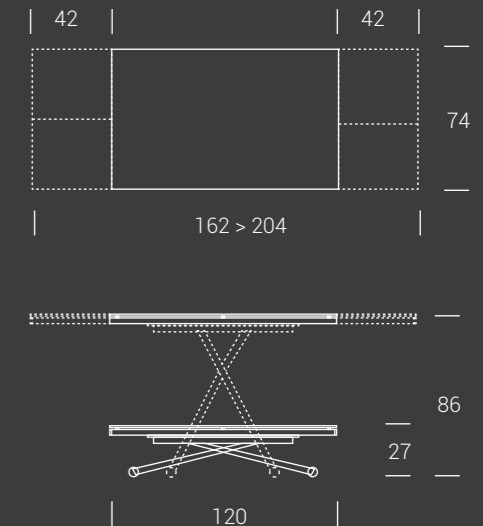

DIARIO

DIARIO, COME EOCA IL NOME, È UN TAVOLINO DI PICCOLE DIMENSIONI CHE CUSTODISCE AL SUO INTERNO TUTTA LA SUA PERSONALITÀ, INFATTI IN POCHE SEMPLICI MOSSE SI TRASFORMA IN "TAVOLO DA CAFFÈ" E ALL'OCCORRENZA DA PRANZO. ESSERE FEDELE COMPAGNO DI OGNI ATTIMO DELLA GIORNATA È LA SUA MISSIONE.

Comme son nom l'indique, c'est une table basse de petites dimensions, qui intègre toute sa personnalité, en effet elle se transforme avec de simples mouvements en table basse et, en l'occurrence, en table de repas. Sa mission: vous être utile à chaque instant dans votre quotidien.

Diario, as the name evokes, is a small dimension table that keeps inside all its personality. In fact, in few easy steps it transforms into a coffee table and also into a dining table, when necessary. Its mission is being a loyal partner to every moment of the day.









Tavolino trasformabile in tavolo da pranzo, base in metallo, meccanismo a gas regolabile in altezza al millimetro da cm 28 a 88, piano rettangolare in nobilitato, legno o effetto malta con prolunga interna a libro. Rotelle a scomparsa.

Table relevable en table de repas, piétement en métal,haussement par vérin-gaz, réglable en hauteur au millimètre de cm 28 à cm 88, plateau rectangulaire en mélamine, bois, effet-béton, avec une rallonge interne à portefeuille. Roulettes intégrées.

Transforming coffee table which turns into a dining table. Metal frame, gas lifting mechanism. Millimetre-adjustable height from cm 28 to cm 88, melamine, stained wood or mortar-look rectangular top, one folded extension. Under-base wheels.

FINITURE PIANO
FINITIONS PLATEAU
TOP FINISHES

NOBILITATO
/ MÉLAMINE
/ MELAMINE

- N20 Natural halifax oak
- N23 Cemento
- N24 Ardesia
- N25 Vintage chiaro
- N30 Morera
- N33 Resina silver
- N34 Resina grigio cenere
- N35 Rovere nodato caramel
- N36 Olmo moka
- N40 Noce Canaletto
- N42 Rovere nero
- N43 Bianco spatolato
- N44 Bianco statuario venato
- N45 Diamond cream
- N46 Pietra grey

LACCATO
/ LAQUÉ
/ LACQUERED

Poro aperto
/ Pores ouverts
/ Open pore

- L31 Bianco luce
- L32 Bianco panna
- L33 Bianco vela
- L34 Grigio corda
- L35 Grigio canapa
- L39 Rosso aragosta
- L40 Tortora

LEGNO IMPIALLACCIATO
/ PLACAGE BOIS
/ VENEER WOOD

- W02 Rovere grigio
- W03 Rovere tabacco
- W04 Rovere nodato
- W06 Rovere juta
- W07 Rovere fumé

- W10 Noce Canaletto

EFFETTO MALTA
/ EFFET-BÉTON
/ MORTAR-LOOK

- E04 Metalli vissuti nichel
- E06 Beton tortora
- E07 Beton nero
- E08 Beton grigio scuro
- E09 Beton grigio chiaro
- E15 Pietra spatolata travertino metallizzato bianco
- E19 Bianco assoluto
- E20 Gros carruba
- E21 Gros ciocco
- E22 Ruggine
- E23 Rock silver
- E24 Rock copper
- E25 Rock cemento

FINITURE BASE
FINITIONS PIÉTEMENT
BASE FINISHES

METALLO
/ MÉTAUX
/ METALS

- M02 Vern. Grisou goffrato
- M04 Vern. Nero opaco
- M05 Cromo lucido
- M09 Cromo nero lucido
- M11 Vern. Grafite goffrato
- M12 Vern. Tortora opaco
- M19 Vern. Bronzo goffrato
- M24 Vern. Bianco goffrato

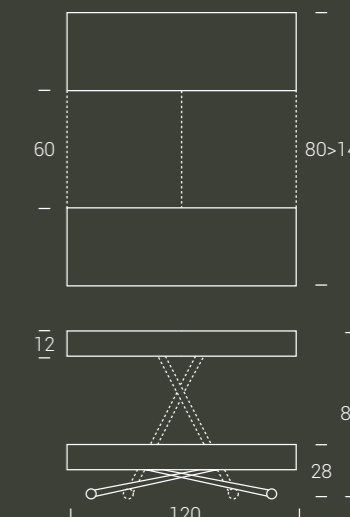

CONSOLLE ESTENSIBILI

GENESI

pg 192

DAVINCI

pg 202

TREK

pg 212

QUAD

pg 220

DAVID

pg 228

SQUARE

pg 238

COMBI

pg 246

FLAP

pg 254

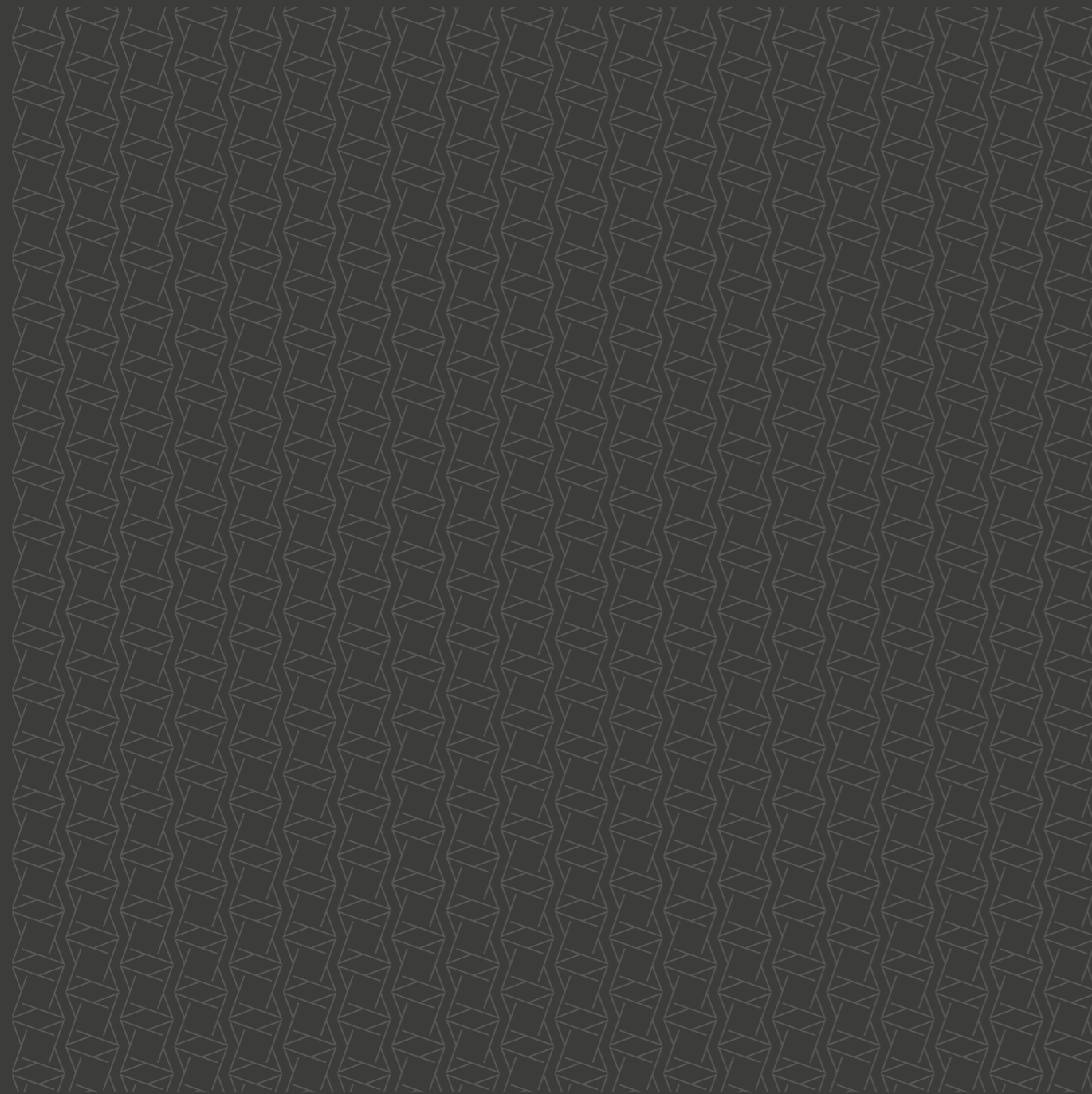

GENESI

GENESI È LA CONSOLLE DI NUOVA GENERAZIONE, IL DESIGN ESPRIME LA SUA FORMA SCULTOREA ESALTATA DALLA STRUTTURA PORTANTE IN METALLO CHE CONVERGE LE SUE LINEE IN UN NODO CENTRALE. LA SUA PERFETTA SIMMETRIA SI ESTENDE COME IN UN ABBRACCIO A SOSTEGNO DEL PIANO. DA CONSOLLE A TAVOLO DA PRANZO SI TRASFORMA SVILUPPANDOSI IN TUTTA LA SUA ESTENSIONE PER OSPITARE DA 4 AD 8 POSTI, L'IMPATTO SCENICO È ESCLUSIVO E FORTEMENTE CARATTERIZZANTE. GENESI, QUANDO L'EVOLUZIONE DELLA FORMA INCIDE SULLO SPAZIO PER CREARE VALORE E OSPITALITÀ.

Genesi est une console de nouvelle génération, le design exprime sa forme sculpturale, glorifiée par sa structure en métal avec ses lignes convergentes vers le nœud central. Sa parfaite symétrie soutient le plateau, comme dans un câlin. Elle se transforme de console à table repas, en s'étendant sur toute sa longueur, pour accueillir jusqu'à 8 personnes. Sa présence est exclusive et très caractérisant. Genesi, lors que l'évolution de la forme touche l'espace pour créer de la valeur et de l'hospitalité.

Genesi is a new generation console, whose design expresses its sculptural shape. The lines of its metal carrying structure converge in a central hub, its perfect symmetry extends like an arm that sustains the top. Genesi transforms from console into a dining table that can host up to 8 people. The scenic effect is exclusive and distinguishing. Genesi, the evolution of shape that affects space to create value and hospitality.





GENESI



GENESI, NELLA SUA MASSIMA ESTENSIONE, SI AVVALE DI UN SOSTEGNO CENTRALE CHE ASSICURA UNA SOLIDA BASE DI APPOGGIO SENZA COMPROMETTERE IL RIGORE ESTETICO CHE CARATTERIZZA LE FORME E ACCOMPAGNA LO STUDIO ATTENTO DEI FATTORI LEGATI ALL' ERGONOMIA.

Genesi, lorsqu'elle est ouverte, est dotée d'un pied de renforce qui assure sa stabilité, sans compromettre la rigueur de son esthétique et de ses formes.

Genesi, in its maximum extension, takes advantage of a central support that guarantees a solid base without compromising the aesthetic accuracy.





FINITURE PIANO
FINITIONS PLATEAU
TOP FINISHES

NOBILITATO
/ MÉLAMINE
/ MELAMINE

- N20 Natural halifax oak
- N23 Cemento
- N24 Ardesia
- N25 Vintage chiaro
- N30 Morera
- N33 Resina silver
- N34 Resina grigio cenere
- N35 Rovere nodato caramel
- N36 Olmo moka
- N40 Noce Canaletto
- N42 Rovere nero
- N43 Bianco spatolato
- N44 Bianco statuario venato
- N45 Diamond cream
- N46 Pietra grey

LACCATO
/ LAQUÉ
/ LACQUERED

- Poro aperto**
/ Pores ouverts
/ Open pore
- L31 Bianco luce
 - L32 Bianco panna
 - L33 Bianco vela
 - L34 Grigio corda
 - L35 Grigio canapa
 - L39 Rosso aragosta
 - L40 Tortora

LEGNO IMPIALLACCIATO
/ PLACAGE BOIS
/ VENEER WOOD

- W02 Rovere grigio
- W03 Rovere tabacco
- W04 Rovere nodato
- W06 Rovere juta
- W07 Rovere fumé

- W10 Noce Canaletto

EFFETTO MALTA
/ EFFET-BÉTON
/ MORTAR-LOOK

- E04 Metalli vissuti nichel
- E06 Beton tortora
- E07 Beton nero
- E08 Beton grigio scuro
- E09 Beton grigio chiaro
- E15 Pietra spatolata travertino metallizzato bianco
- E19 Bianco assoluto
- E20 Gros carruba
- E21 Gros ciocco
- E22 Ruggine
- E23 Rock silver
- E24 Rock copper
- E25 Rock cemento

CERAMICA
/ CÉRAMIQUE
/ CERAMIC

- K01 Fokos Sale
- K02 Fokos Terra
- K03 Fokos Piombo
- K04 Noir Desir lucido
- K05 Bianco Statuario venato lucido
- K06 Diamond Cream lucido
- K07 Pietra Grey lucida
- K09 Oxide Nero
- K10 Oxide Bianco
- K11 Pietra Savoia Antracite
- K12 Pietra di Savoia Perla
- K13 Calacatta Gold lucido
- K14 Emperador lucido
- K15 Noir Desir opaco
- K16 Pietra Grey opaco
- K17 Calacatta Gold opaco
- K18 Bianco Statuario venato opaco
- K19 Diamond Cream opaco
- K20 Emperador opaco

Consolle estensibile, struttura in metallo, meccanismo telescopico in alluminio, piano in nobilitato, laccato, legno, effetto malta o ceramica, 3 o 5 allunghe. Gambe centrali di supporto.

Console extensible, structure en métal, mécanique télescopique en aluminium, plateau mélamine, laqué, bois, effet-béton ou céramique, 3 ou 5 rallonges. Pieds centraux de support.

Metal frame extending console-table, aluminium telescopic mechanism, top in melamine, lacquered, wood, mortar-look or ceramic, 3 or 5 extensions. Central supporting legs.

Consolle fissa, struttura in metallo, piano in nobilitato, legno, effetto malta o ceramica.

Console fixe, structure en métal, plateau mélamine, bois, effet-béton ou céramique.

Fix metal frame console-table, top in melamine, wood, mortar-look or ceramic.

FINITURE BASE
FINITIONS PIÉTEMENT
BASE FINISHES

METALLO
/ MÉTAUX
/ METALS

- M02 Vern. grisou goffrato
- M04 Vern. nero opaco
- M11 Vern. grafite goffrato
- M12 Vern. tortora opaco
- M19 Vern. bronzo goffrato
- M24 Vern. bianco goffrato

ALLUNGABILE

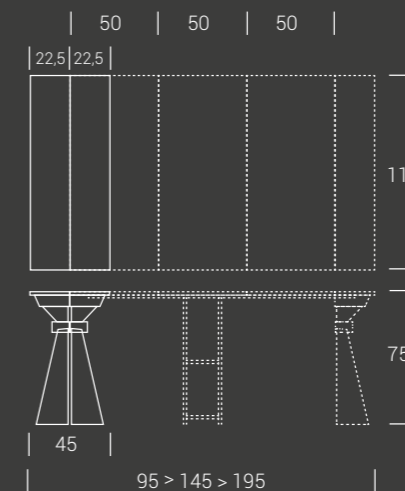

FISSO



ALLUNGABILE

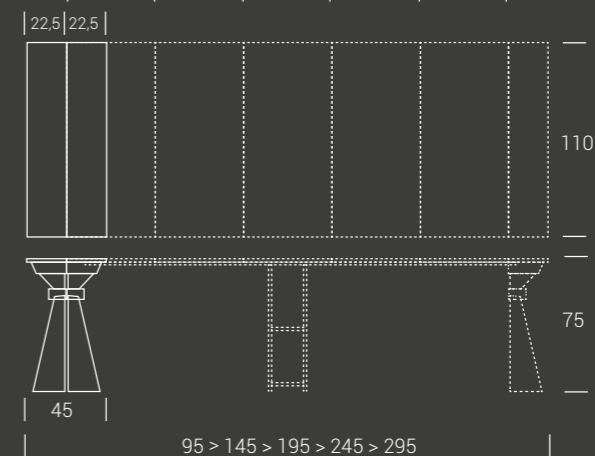

DAVINCI

GENIALE, COME IL NOME A CUI SI ISPIRA, DAVINCI È UN COMPLEMENTO D'ARREDO ORIGINALE ED ESCLUSIVO, MA SE A PRIMA VISTA LA SUA FORMA COMPATTA EVOCA UNA VALIGIA, IL VIAGGIO CHE È IN GRADO DI INTRAPRENDERE È SORPRENDENTE. UN PICCOLO SPOSTAMENTO DALLA PARETE IN CENTRO STANZA E POCHE MOVIMENTI TRASFORMANO UNA CONSOLLE IN UN PRATICISSIMO TAVOLO DA PRANZO: LA STRUTTURA LEGGERA, MA ESTREMAMENTE STABILE, SORREGGE IL PIANO REALIZZATO IN ROVERE MASSICCIO DALL'ASPETTO ESTETICO VINTAGE CHE SUGGERISCE L'ESPERIENZA IN "MATERIA".

Autant géniale que le nom qui l'inspire, Davinci est une pièce d'ameublement originale et unique, mais, si à première vue ses formes compactes évoquent une valise, le voyage qu'elle sait aborder est tout de même surprenant. Un petit déplacement du mur au centre de la pièce et quelques simples mouvements transforment cette console en une table repas: sa structure légère, mais très stable, soutient le plateau en vrai chêne vieux au goût "vintage" qui laisse entendre de l'expérience dans le domaine.

As ingenious as the name to which it's inspired, Davinci is an original and exclusive furnishing, but if at first glance its shape is evoking a luggage, the trip it can take is astonishing. A small displacement from the wall to the room center and a few easy movements turn the console in a practical dining table: its light, but extremely stable structure, is perfectly supporting the top made by real old oak recalling a vintage look and implying a certain experience on the subject as well.





DAVINCI

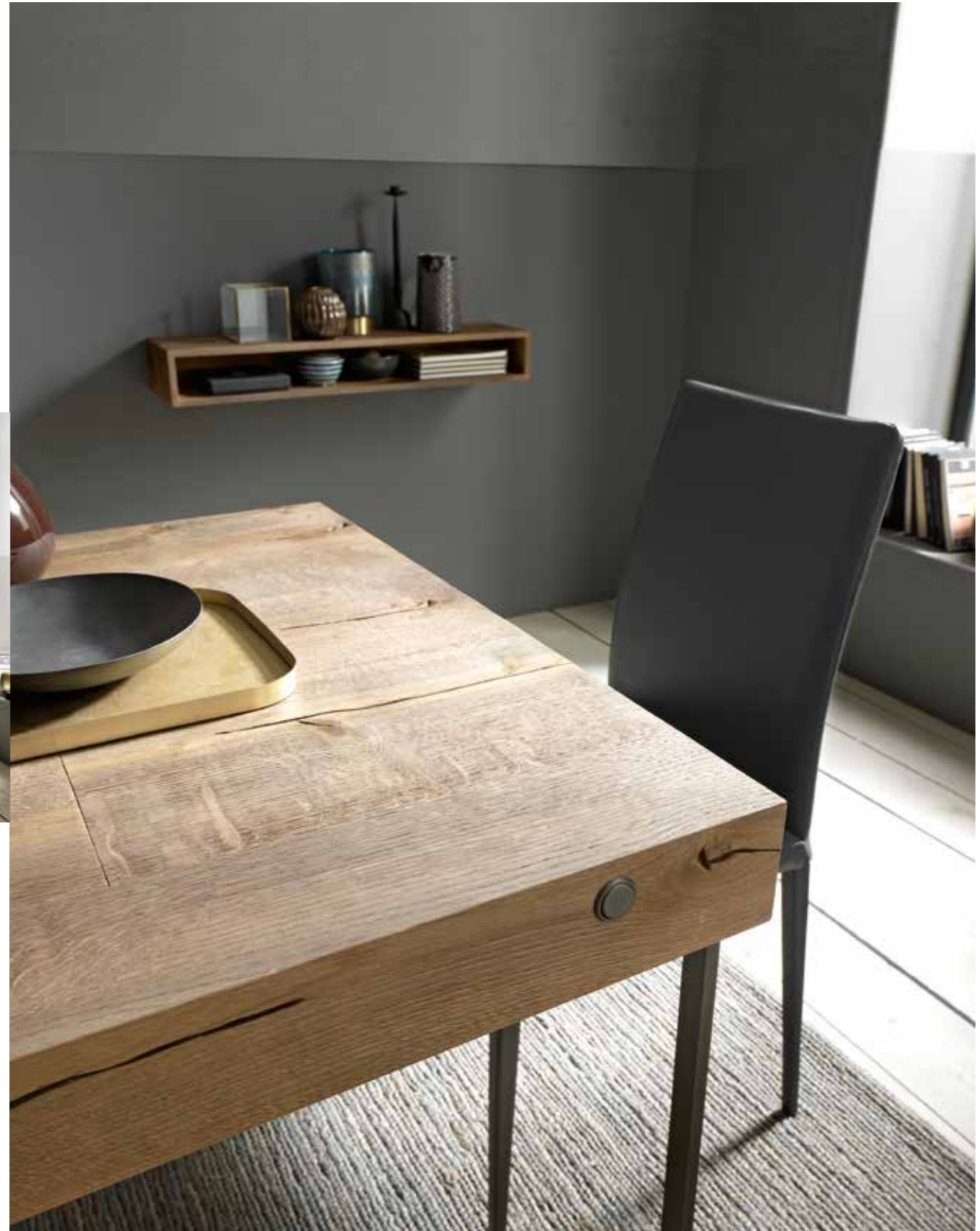



DAVINCI / SHELF



FINITURE PIANO FINITIONS PLATEAU TOP FINISHES

NOBILITATO / MÉLAMINE / MELAMINE

N20	Natural halifax oak
N23	Cemento
N24	Ardesia
N25	Vintage chiaro
N30	Morera
N33	Resina silver
N34	Resina grigio cenere
N35	Rovere nodato caramel
N36	Olmo moka
N40	Noce Canaletto
N42	Rovere nero
N43	Bianco spatolato
N44	Bianco statuario venato
N45	Diamond cream
N46	Pietra grey

LACCATO / LAQUÉ / LACQUERED

Poro aperto / Pores ouverts / Open pore

L31	Bianco luce
L32	Bianco panna
L33	Bianco vela
L34	Grigio corda
L35	Grigio canapa
L39	Rosso aragosta
L40	Tortora

LEGNO IMPIALLACCIATO / PLACAGE BOIS / VENEER WOOD

W02	Rovere grigio
W03	Rovere tabacco
W04	Rovere nodato
W06	Rovere juta
W07	Rovere fumé
W10	Noce Canaletto

LEGNO MASSICCIO / BOIS MASSIF / SOLID WOOD

W21	Rovere vecchio massiccio termotrattato
W32	Rovere vecchio massiccio naturale
W33	Rovere vecchio massiccio grigio

EFFETTO MALTA / EFFET-BÉTON / MORTAR-LOOK

E04	Metalli vissuti nichel
E06	Beton tortora
E07	Beton nero
E08	Beton grigio scuro
E09	Beton grigio chiaro
E15	Pietra spatolata travertino metallizzato bianco
E19	Bianco assoluto
E20	Gros carruba
E21	Gros ciocco
E22	Ruggine
E23	Rock silver
E24	Rock copper
E25	Rock cemento

Consolle estensibile, struttura
in metallo, piani apribili a
compasso in nobilitato, legno
o effetto malta, due prolunghie
interne a libro.

Console extensible, structure en métal,
plateaux pivotants en mélamine, bois,
ou effet-béton, 2 rallonges intégrées
portefeuille.

Metal frame extending console-table,
pivotable tops in melamine, wood
or mortar-look. 2 inside folded
extensions.

FINITURE BASE FINITIONS PIÉTEMENT BASE FINISHES

METALLO / MÉTAUX / METALS

M11 Verniciato grafite goffrato

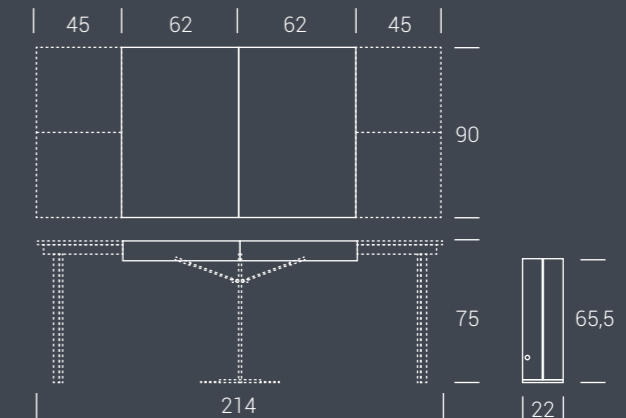

DAVINCI SHELF OPTIONAL

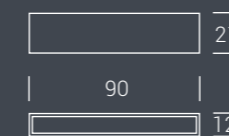

**Mensola in nobilitato,
legno o effetto malta.**

Etagère en mélamine, bois
ou effet-béton.

Shelf in melamine, wood
or mortar-look.

TREK

TREK SI PRESENTA COME UN OGGETTO D'ARREDO STRAORDINARIO. LA SUA VERSATILITÀ È TALE DA TRASFORMARSI DA CONSOLLE SALVASPAZIO AD AMPIO TAVOLO DA PRANZO: CIÒ È POSSIBILE GRAZIE ALL'INGEGNOSO SISTEMA DI ALLUNGHE COLLOCATO ALL'INTERNO DEL PIANO, VESTITO IN NOBILITATO CEMENTO PER "L'OCCASIONE".

Trek se présente comme un objet d'ameublement extraordinaire. Sa versatilité est de nature à se transformer de simple console en une grande table de repas: cela est possible grâce à l'astucieux système d'extension intégré à l'intérieur du plateau habillé, pour l'occasion, en mélamine finition béton.

Trek is showing-up as an extraordinary home furnishing. Its versatility is such as to be turned from a wall console to a large dining table: this is possible thanks to a clever extending mechanism integrated into the top, dressed, for the occasion, with a melamine top in concrete finish.





TREK SI PREPARA AD ACCOGLIERE OSPITI INATTESI CON SEMPLICITÀ: IL RISULTATO ESTETICO È PERFETTO, LA SOLIDITÀ NELLA LUNGHEZZA DI TRE METRI È GARANTITA DALLA STRUTTURA METALLICA EXTENSO, COLLOCATA AL CENTRO DEL PIANO PER RAFFORZARE LA STABILITÀ.

Trek se prépare à accueillir les invités inattendus avec simplicité: le résultat esthétique est parfait, la solidité en longueur, une fois ouverte, est garantie par la structure en métal Extenso, située au milieu du plateau pour en renforcer la stabilité.

Trek gets ready to welcome unexpected guests with simplicity: the aesthetic result is perfect, the solidity in length, once open, is guaranteed by the metal structure Extenso, located in the middle of the top to enhance stability.





FINITURE PIANO FINITIONS PLATEAU TOP FINISHES

NOBILITATO / MÉLAMINE / MELAMINE

N20	Natural halifax oak
N23	Cemento
N24	Ardesia
N25	Vintage chiaro
N30	Morera
N33	Resina silver
N34	Resina grigio cenere
N35	Rovere nodato caramelo
N36	Olmo moka
N40	Noce Canaletto
N42	Rovere nero
N43	Bianco spatolato
N44	Bianco statuario venato
N45	Diamond cream
N46	Pietra grey

LACCATO / LAQUÉ / LACQUERED

Poro aperto / Pores ouverts / Open pore	Opaco / Mat / Matt	Lucido / Brilliant / High gloss	
L31	L51	L01	Bianco luce
L32	L52		Bianco panna
L33	L53		Bianco vela
L34	L54		Grigio corda
L35	L55		Grigio canapa
L39	L59		Rosso aragosta
L40	L60		Tortora

LEGNO IMPIALLACCIATO / PLACAGE BOIS / VENEER WOOD

W02	Rovere grigio
W03	Rovere tabacco
W04	Rovere nodato
W06	Rovere juta
W07	Rovere fumé
W10	Noce Canaletto

EFFETTO MALTA / EFFET-BÉTON / MORTAR-LOOK

E04	Metalli vissuti nichel
E06	Beton tortora
E07	Beton nero
E08	Beton grigio scuro
E09	Beton grigio chiaro
E15	Pietra spatolata travertino metallizzato bianco
E19	Bianco assoluto
E20	Gros carruba
E21	Gros ciocco
E22	Ruggine
E23	Rock silver
E24	Rock copper
E25	Rock cemento

CERAMICA / CÉRAMIQUE / CERAMIC

K01	Fokos Sale
K02	Fokos Terra
K03	Fokos Piombo
K04	Noir Desir lucido
K05	Bianco Statuario venato lucido
K06	Diamond Cream lucido
K07	Pietra Grey lucida
K09	Oxide Nero
K10	Oxide Bianco
K11	Pietra Savoia Antracite
K12	Pietra di Savoia Perla
K13	Calacatta Gold lucido
K14	Emperador lucido
K15	Noir Desir opaco
K16	Pietra Grey opaco
K17	Calacatta Gold opaco
K18	Bianco Statuario venato opaco
K19	Diamond Cream opaco
K20	Emperador opaco

Consolle estensibile, struttura in metallo, meccanismo telescopico in alluminio, piano in nobilitato, laccato, legno, effetto malta o ceramica, 3 o 5 allunghe. Gambe centrali di supporto o porta allunghe opzionale Extenso.

Console extensible, structure en métal, mécanique télescopique en aluminium, plateau mélamine, laqué, bois, effet-béton ou céramique, 3 ou 5 rallonges. Pieds centraux de support ou rack à rallonges optionnel Extenso.

Metal frame extending console-table, aluminium telescopic mechanism, top in melamine, lacquered, wood, mortar-look or ceramic, 3 or 5 extensions. Central supporting legs or optional extensions holder Extenso.

FINITURE BASE FINITIONS PIÉTEMENT BASE FINISHES

METALLO / MÉTAUX / METALS

M02	Verniciato grigio goffrato
M04	Verniciato nero opaco
M11	Verniciato grafite goffrato
M12	Verniciato tortora opaco
M19	Verniciato bronzo goffrato
M24	Verniciato bianco goffrato

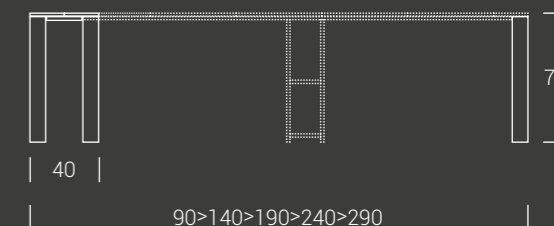
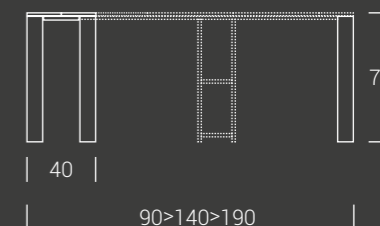
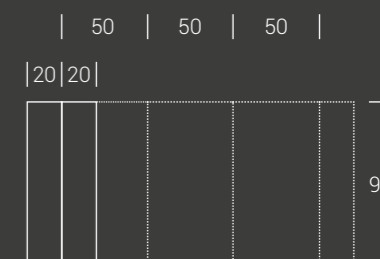

EXTENSO OPTIONAL

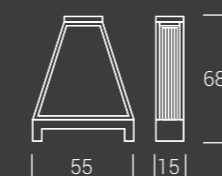

Struttura metallica girevole porta allunghe per consolle: Combi, Quad e Trek.

Structure métallique pivotante porte-rallonges pour les consoles: Combi, Quad, Trek.

Swivel metal frame, extensions holder for consoles: Combi, Quad, Trek.

Q U A D

IL TAVOLO IN ASSOLUTO PIÙ VERSATILE E SALVASPAZIO, NON È UN TAVOLO, MA UNA CONSOLLE! QUAD PUÒ ESSERE POSIZIONATA OVUNQUE GRAZIE ALLA SUA LIMITATA PROFONDITÀ (APPENA 40 CM), MA NELLA VERSIONE ALLUNGATA OSPITA COMODAMENTE FINO A 12 PERSONE. PROPRIO QUELLO CHE CI VUOLE PER ARREDARE SOGGIORNO E SALA DA PRANZO SFRUTTANDO DUE MOBILI IN UNO.

La plus versatile pièce des produits "gain de place" n'est pas une table, mais une console! Quad peut être placée partout grâce à sa petite profondeur de seulement 40 cm, mais en position ouverte, elle permet d'accueillir jusqu'à 12 personnes confortablement. Juste ce qu'il faut pour décorer en même temps le salon et la salle à manger.

The most versatile and space-saving solution is not a table but a console! Quad can be placed everywhere thanks to its limited width (just 40 cm), but in its extended version can host up to 12 people. This is exactly what is needed to furnish a living room and dining room exploiting two solutions in one.



Q U A D



QUAD



QUAD & EXTENSO



FINITURE PIANO FINITIONS PLATEAU TOP FINISHES

NOBILITATO / MÉLAMINE / MELAMINE

N20	Natural halifax oak
N23	Cemento
N24	Ardesia
N25	Vintage chiaro
N30	Morera
N33	Resina silver
N34	Resina grigio cenere
N35	Rovere nodato caramél
N36	Olmo moka
N40	Noce Canaletto
N42	Rovere nero
N43	Bianco spatolato
N44	Bianco statuario venato
N45	Diamond cream
N46	Pietra grey

LACCATO / LAQUÉ / LACQUERED

Poro aperto / Pores ouverts / Open pore	Opaco / Mat / Matt	Lucido / Brilliant / High gloss	
L31	L51	L01	Bianco luce
L32	L52		Bianco panna
L33	L53		Bianco vela
L34	L54		Grigio corda
L35	L55		Grigio canapa
L39	L59		Rosso aragosta
L40	L60		Tortora

LEGNO IMPIALLACCIATO / PLACAGE BOIS / VENEER WOOD

W02	Rovere grigio
W03	Rovere tabacco
W04	Rovere nodato
W06	Rovere juta
W07	Rovere fumé
W10	Noce Canaletto

EFFETTO MALTA / EFFET-BÉTON / MORTAR-LOOK

E04	Metalli vissuti nichel
E06	Beton tortora
E07	Beton nero
E08	Beton grigio scuro
E09	Beton grigio chiaro
E15	Pietra spatolata travertino metallizzato bianco
E19	Bianco assoluto
E20	Gros carruba
E21	Gros ciocco
E22	Ruggine
E23	Rock silver
E24	Rock copper
E25	Rock cemento

CERAMICA / CÉRAMIQUE / CERAMIC

K01	Fokos Sale
K02	Fokos Terra
K03	Fokos Piombo
K04	Noir Desir lucido
K05	Bianco Statuario venato lucido
K06	Diamond Cream lucido
K07	Pietra Grey lucida
K09	Oxide Nero
K10	Oxide Bianco
K11	Pietra Savoia Antracite
K12	Pietra di Savoia Perla
K13	Calacatta Gold lucido
K14	Emperador lucido
K15	Noir Desir opaco
K16	Pietra Grey opaco
K17	Calacatta Gold opaco
K18	Bianco Statuario venato opaco
K19	Diamond Cream opaco
K20	Emperador opaco

Consolle estensibile, struttura in metallo, meccanismo telescopico in alluminio, piano in nobilitato, laccato, legno, effetto malta o ceramica, 3 o 5 allunghe. Gambe centrali di supporto o porta allunghe opzionale Extenso.

métal, mécanique télescopique en aluminium, plateau mélamine, laqué, bois, effet-béton ou céramique, 3 ou 5 rallonges. Pieds centraux de support ou rack à rallonges optionnel Extenso.

Aluminum telescopic mechanism, melamine, lacquered, stained wood, mortar-look top ou céramique, 3 or 5 extensions. Central supporting legs or optional extensions holder Extenso.

Console estensibile, structure en

Metal frame extending console-table.

FINITURE BASE FINITIONS PIÉTEMENT BASE FINISHES

METALLO / MÉTAUX / METALS

M02	Verniciato grisou goffrato
M04	Verniciato nero opaco
M11	Verniciato grafite goffrato
M12	Verniciato tortora opaco
M19	Verniciato bronzo goffrato
M24	Verniciato bianco goffrato

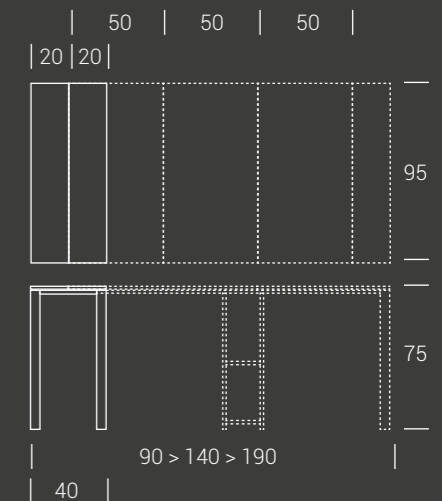

EXTENSO OPTIONAL

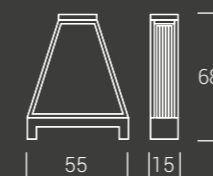

Struttura metallica girevole porta allunghe per consolle: Combi, Quad e Trek.

Structure métallique pivotante porte-rallonges pour les consoles: Combi, Quad, Trek.

Swivel metal frame, extensions holder for consoles: Combi, Quad, Trek.

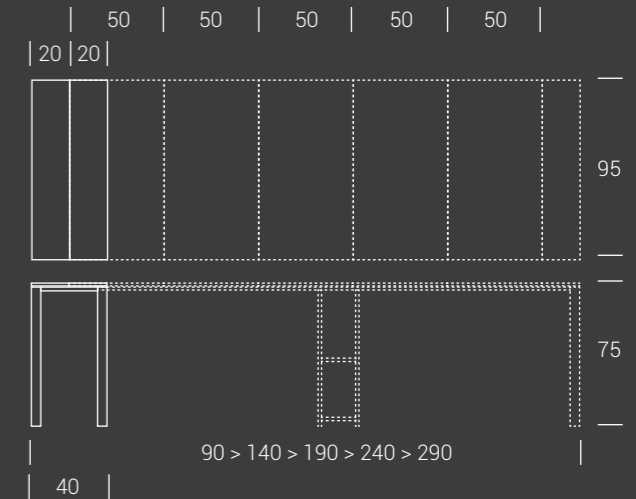

DAVID

È UNA CONSOLE PERFETTA PER VALORIZZARE LAMPADE E SOPRAMMOBILI O UN PRATICO TAVOLO DA PRANZO? CHE SIA IN ENTRATA, IN SALOTTO O IN SALA DA PRANZO, È UN ELEMENTO D'ARREDO CHE CON LA SUA CAPACITÀ DI TRASFORMARSI SA SORPRENDERE TUTTI. DAVID CRESCE CON LA TUA FAMIGLIA.

C'est une console parfaite qui met en valeur vos lampes et objets? Ou bien c'est une table de repas pratique? Dans la hall d'entree ou dans la salle a manger, ce mobilier, qui sait se transformer, nous surprend. David grandit avec votre famille.

Is it a perfect console to enhance the value of lamps and other ornaments or is it a practical dining table? Both in the entrance, or in the living room it's a piece of art that is able to amaze everyone with its ability to transform. David grows up with your family.



DAVID



DAVID



DAVID



DAVID



Consolle estensibile in laccato o legno, meccanismo telescopico in alluminio, 3 o 5 allunghe. Gambe centrali di supporto girevoli in tinta con la consolle.

Console extensible en laqué ou bois, mécanique télescopique en aluminium, 3 o 5 rallonges. Pieds centraux pivotants de support coordonnés à la console.

Lacquered or wood frame extending console-table, aluminium telescopic mechanism, 3 o 5 extensions. Central rotating supporting legs matching de console.

FINITURE FINITIONS FINISHES

LEGNO IMPIALLACCIATO / PLACAGE BOIS / VENEER WOOD

W02	Rovere grigio
W03	Rovere tabacco
W04	Rovere nodato
W06	Rovere juta
W07	Rovere fumé
W10	Noce Canaletto

LACCATO / LAQUÉ / LACQUERED

Poro aperto
/ Pores ouverts
/ Open pore

L31
L32
L33
L34
L35
L39
L40

Opaco
/ Mat
/ Matt

L51 Bianco luce
L52 Bianco panna
L53 Bianco vela
L54 Grigio corda
L55 Grigio canapa
L59 Rosso aragosta
L60 Tortora

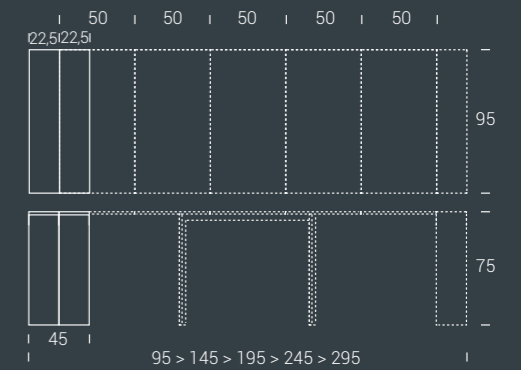
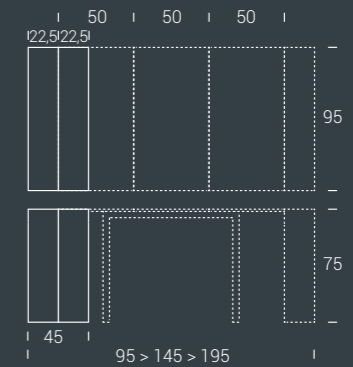

S Q U A R E

LA ZONA LIVING ACQUISTA UNA MARCIA IN PIÙ CON SQUARE, LA CONSOLLE DALLA STRUTTURA IMPORTANTE, CHE NON SCOMPARE NELL'AMBIENTE, MA NE È PROTAGONISTA E NON PERDE LA SUA PRESENZA SCENICA NEMMENO QUANDO DIVENTA UN TAVOLO DA PRANZO SOLIDO E FUNZIONALE.

Le salon aura une nouvelle allure grâce à Square, la console avec une structure importante, laquelle ne se cache pas dans le décor. Elle sera la protagoniste de votre maison, même en position ouverte, comme table de repas solide et fonctionnelle, avec son grand charme.

Square is a console with an important structure, that doesn't disappear in the room, indeed it becomes the main character both when closed and when opened.

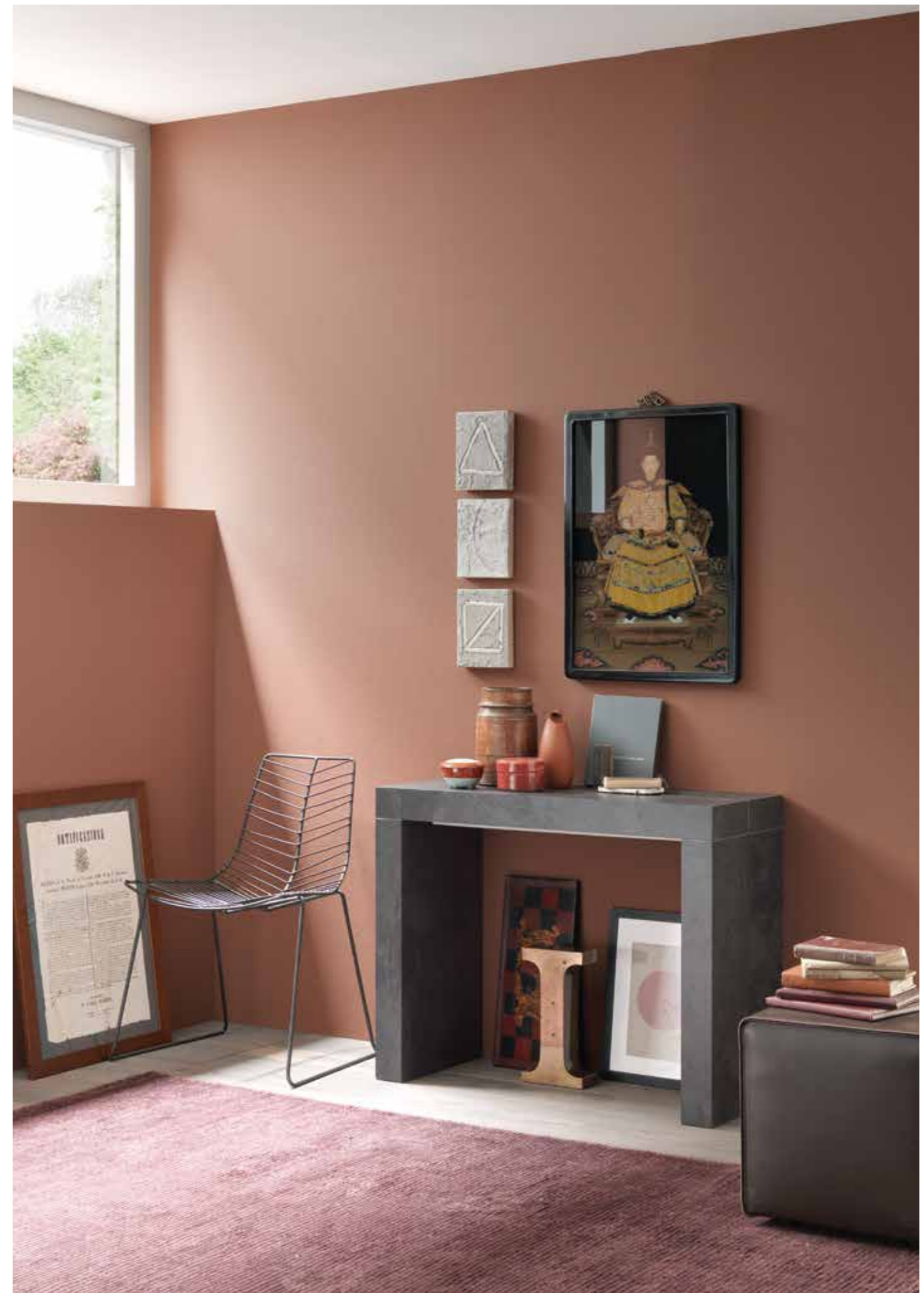

S Q U A R E



S Q U A R E



S Q U A R E

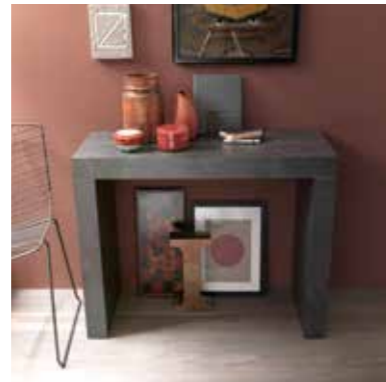

Consolle estensibile in nobilitato, meccanismo telescopico in alluminio, 3 o 5 allunghe. Gambe centrali di supporto.

Console extensible en mélamine, mécanique télescopique en aluminium, 3 ou 5 rallonges. Pieds centraux de support.

Melamine frame extending console-table, aluminum telescopic mechanism, 3 or 5 extensions. Central supporting legs.

FINITURE FINITIONS FINISHES

NOBILITATO / MÉLAMINE / MELAMINE

- N20 Natural halifax oak
- N23 Cemento
- N24 Ardesia
- N25 Vintage chiaro
- N30 Morera
- N33 Resina silver
- N34 Resina grigio cenere
- N35 Rovere nodato caramel
- N36 Olmo moka
- N40 Noce Canaletto
- N42 Rovere nero
- N43 Bianco spatolato
- N44 Bianco statuario venato
- N45 Diamond cream
- N46 Pietra grey

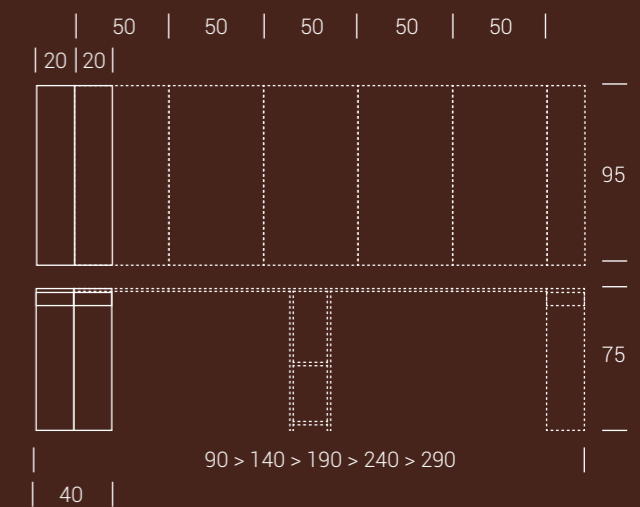
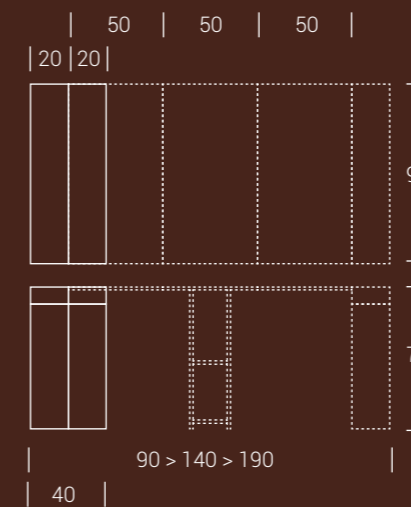

COMBI

IL RIGORE FORMALE DELLA CONSOLLE COMBI SI TRAFORMA IN RAFFINATA E AMPIA OSPITALITÀ QUANDO APRENDOSI IN TUTTA LA SUA ESTENSIONE ACCOGLIE COMODAMENTE OTTO OSPITI A PRANZO. L'ATTUALITÀ DI COMBI È RAPPRESENTATA DALLA CONTINUITÀ DEL MATERIALE CHE COINVOLGE PIANO E STRUTTURA ADEGUANDOSI ALL'AMBIENTE IN TOTALE ARMONIA.

La rigueur formelle de la console Combi se transforme en élégante hospitalité, lorsque, en s'ouvrant complètement, elle accueille jusqu'à 8 personnes très à l'aise. L'actualité de Combi réside dans la continuité de la matière de son plateau et de sa structure, en s'adaptant à l'environnement en parfaite harmonie.

The formal accuracy of the console Combi transforms in refined and broad hospitality as when you open it at its maximum extensions, it can comfortably host up to eight people. The newness of this console is represented by the continuity of the material, which involves top and structure adapting to the surrounding space in complete harmony.



COMBI





COMBI & EXTENSO



FINITURE FINITIONS FINISHES

NOBILITATO / MÉLAMINE / MELAMINE

- N20 Natural halifax oak
- N23 Cemento
- N24 Ardesia
- N25 Vintage chiaro
- N30 Morera
- N33 Resina silver
- N34 Resina grigio cenere
- N35 Rovere nodato caramel
- N36 Olmo moka
- N40 Noce Canaletto
- N42 Rovere nero
- N43 Bianco spatolato
- N44 Bianco statuario venato
- N45 Diamond cream
- N46 Pietra grey

Consolle estensibile in nobilitato, meccanismo telescopico in alluminio, 3 o 5 allunghe. Gambe centrali di supporto o porta allunghe opzionale Extenso.

Console extensible en mélamine, mécanique télescopique en aluminium, 3 ou 5 rallonges. Pieds centraux de support ou rack à rallonges optionnel Extenso.

Melamine frame extending console-table, aluminum telescopic mechanism, 3 or 5 extensions. Central supporting legs or optional extensions holder Extenso.

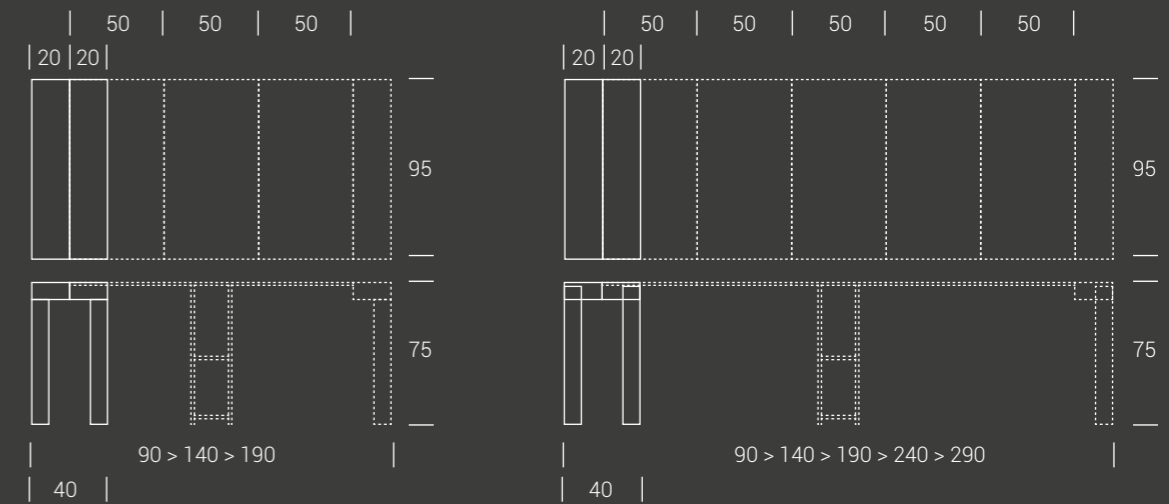

EXTENSO OPTIONAL

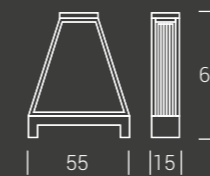

Struttura metallica girevole porta allunghe per consolle: Combi, Quad e Trek.

Structure métallique pivotante porte-rallonges pour les consoles: Combi, Quad, Trek.

Swivel metal frame, extensions holder for consoles: Combi, Quad, Trek.

FLAP

FLAP É L'ESPRESSIONE DELLA MODERNITÀ, SFILA CON UN LOOK "BLACK AND WHITE" MOLTO TRENDY. LA STRUTTURA SI APRE A LIBRO DANDO VITA AD UN ORIGINALE TAVOLO DA PRANZO O TAVOLO STUDIO ADEGUANDOSI PERFETTAMENTE ALLO SPIRITO LIBERO DI CHI CONSIDERA IL "CAMBIAMENTO" UNA COSTANTE.

Flap est le reflet de la modernité, très chic avec son look «black-and-white». Sa structure portefeuille donne vie à une originale table repas et table de travail, en s'adaptant parfaitement à l'esprit libre de ceux qui considèrent le changement une constante.

Flap is the expression of modernity. It appears with a trendy black-and-white look. The structure opens like a book giving life to an original dining table perfectly adapting to the free spirit of those who believe "change" to be a necessity.





FLAP



FLAP



**Consolle estensibile,
struttura in metallo, piano
raddoppiabile a libro in
nobilitato o effetto malta.**

Console extensible, structure en métal,
plateaux portefeuille en mélamine ou
effet-béton.

Metal frame extending console-
table, doubling top in melamine or
mortar-look.

FINITURE PIANO FINITIONS PLATEAU TOP FINISHES

NOBILITATO / MÉLAMINE / MELAMINE

N20	Natural halifax oak
N23	Cemento
N24	Ardesia
N25	Vintage chiaro
N30	Morera
N33	Resina silver
N34	Resina grigio cenere
N35	Rovere nodato caramel
N36	Olmo moka
N40	Noce Canaletto
N42	Rovere nero
N43	Bianco spatolato
N44	Bianco statuario venato
N45	Diamond cream
N46	Pietra grey

EFFETTO MALTA / EFFET-BÉTON / MORTAR-LOOK

E04	Metalli vissuti nichel
E06	Beton tortora
E07	Beton nero
E08	Beton grigio scuro
E09	Beton grigio chiaro
E15	Pietra spatolata travertino metallizzato bianco
E19	Bianco assoluto
E20	Gros carruba
E21	Gros ciocco
E22	Ruggine
E23	Rock silver
E24	Rock copper
E25	Rock cemento

FINITURE BASE FINITIONS PIÉTEMENT BASE FINISHES

METALLO / MÉTAUX / METALS

M02	Verniciato grisou gofrato
M04	Verniciato nero opaco
M11	Verniciato grafite gofrato
M12	Verniciato tortora opaco
M19	Verniciato bronzo gofrato
M24	Verniciato bianco gofrato

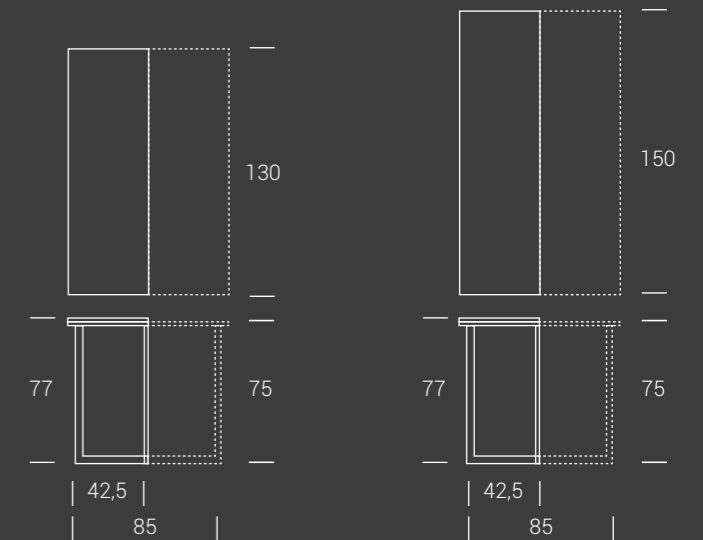

TAVOLI DA PRANZO

SINTESI

pg 264

TRINITY

pg 272

CELSIUS

pg 278

FAHRENHEIT ROUND

pg 284

SUN

pg 290

GIADA

pg 298

FAHRENHEIT

pg 306

MERIDIANO

pg 314

RIBOT

pg 320

RIBOT WOOD

pg 328

SIPARIO

pg 336

PICK-UP

pg 346

ARGON

pg 354

TEOREMA

pg 362

STORM

pg 370

COMPASSO

pg 376

TOWER MAXI

pg 384

S I N T E S I

IL SOSTEGNO CENTRALE IN METALLO CARATTERIZZA IL TAVOLO SINTESI, GARANTENDONE LA STABILITÀ DURANTE IL MOVIMENTO DI APERTURA. IL VANO INTERNO CONTIENE L'ALLUNGA RIPIEGATA, PRONTA PER AGGIUNGERE SPAZIO ALLA CONVIVIALITÀ.

Le piètement central en métal caractérise la table Sintesi, en assurant la stabilité pendant l'ouverture du plateau. Le cadre extensible cache la rallonge portefeuille, prête à rajouter de la place pour la convivialité.

The central metal support distinguishes table Sintesi, guaranteeing stability during the opening movement. The internal compartment contains the extension, ready to add space for conviviality.



S I N T E S I



S I N T E S I



I DIVERSI MATERIALI UTILIZZATI PER IL PIANO E PER L'ALLUNGA ARRICCHISCONO E COMPLETANO IL DESIGN DI OGNI AMBIENTE, PER SOFISTICATE SOLUZIONI DI ARREDO CHE NON TRALASCIANO ALCUN DETTAGLIO.

Les différents matériaux utilisés pour le plateau et la rallonge donnent de la valeur au design de toutes les pièces, pour une déco raffinée et attentive à tous les détails.

The different materials used for the top and the extension enrich and complete the design of the living space; it is a sophisticated solution that does not leave out any detail.

S I N T E S I



FINITURE PIANO FINITIONS PLATEAU TOP FINISHES

NOBILITATO / MÉLAMINE / MELAMINE

N20	Natural halifax oak
N23	Cemento
N24	Ardesia
N25	Vintage chiaro
N30	Morera
N33	Resina silver
N34	Resina grigio cenere
N35	Rovere nodato caramel
N36	Olmo moka
N40	Noce Canaletto
N42	Rovere nero
N43	Bianco spatolato
N44	Bianco statuario venato
N45	Diamond cream
N46	Pietra grey

CERAMICA / CÉRAMIQUE / CERAMIC

K01	Fokos Sale
K02	Fokos Terra
K03	Fokos Piombo
K04	Noir Desir lucido
K05	Bianco Statuario venato lucido
K06	Diamond Cream lucido
K07	Pietra Grey lucida
K09	Oxide Nero
K10	Oxide Bianco
K11	Pietra Savoia Antracite
K12	Pietra di Savoia Perla
K13	Calacatta Gold lucido
K14	Emperador lucido
K15	Noir Desir opaco
K16	Pietra Grey opaco
K17	Calacatta Gold opaco
K18	Bianco Statuario venato opaco
K19	Diamond Cream opaco
K20	Emperador opaco

LAMINAM
SUPERIOR NATURAL SURFACES

Tavolo da pranzo, struttura allungabile in metallo, meccanismo telescopico, piano in ceramica o in nobilitato, prolunga interna a libro.

Tavolo da pranzo fisso, struttura in metallo, piano in ceramica o in nobilitato.

Table de repas, mécanisme télescopique en métal, plateau en céramique ou en mélamine, rallonge intégrée à portefeuille.

Table de repas fixe, structure en métal, plateau en céramique ou en mélamine.

Dining table, telescopic extending mechanism, ceramic or melamine top, inside folded extension.

Fix dining table, metal frame, ceramic or melamine top.

FINITURE BASE FINITIONS PIÉTEMENT BASE FINISHES

METALLO / MÉTAUX / METALS

M02	Vern. Grisou goffrato
M04	Vern. Nero opaco
M11	Vern. Grafite goffrato
M12	Vern. Tortora opaco
M19	Vern. Bronzo goffrato
M24	Vern. Bianco goffrato

ALLUNGABILE EXTENSIBLE / EXTENDABLE

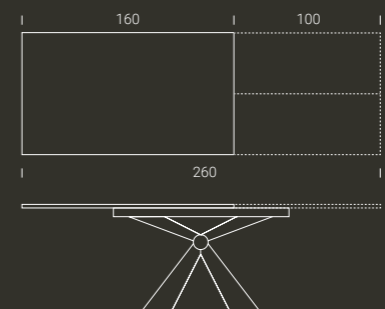
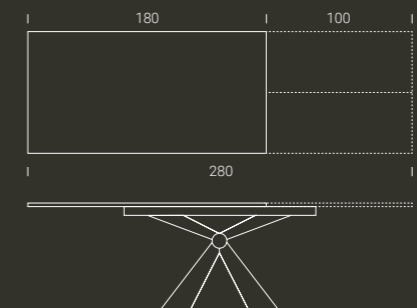
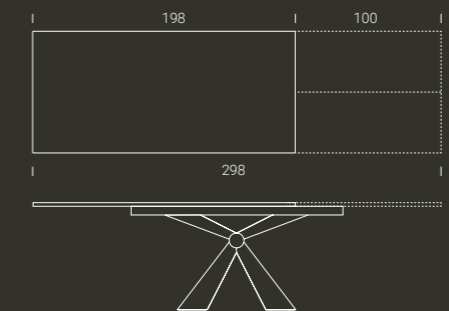

FISSO FIXE / FIXED

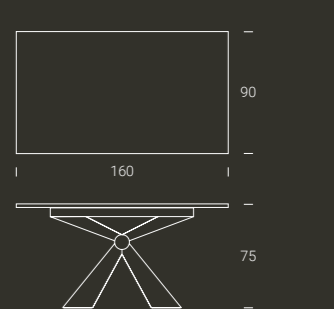
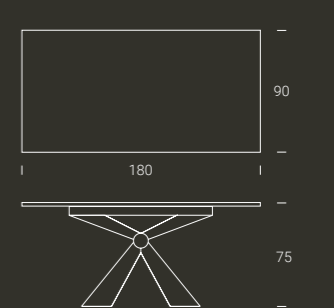
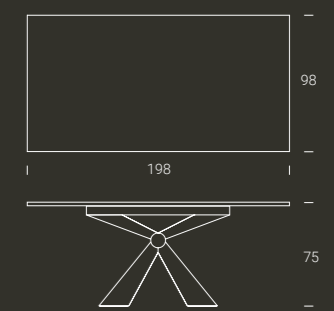

TRINITY

TRINITY È UN GRANDE TAVOLO DALL'ASPETTO MAESTOSO. IL SOTTILE PIANO IN CERAMICA, ACCOPPIATO AL PANNELLO DALLO SPESSORE INCLINATO, SCORRE SUL MECCANISMO ALLUNGANDOSI E AUMENTANDO I POSTI A TAVOLA.

Trinity est une table grande, au design important. Le fin plateau en céramique, au-dessus du support avec les bords inclinés, s'étend grâce à la mécanique extensible, pour augmenter la place disponible.

Trinity is a big table with a majestic aspect. The thin ceramic top paired with the sloped panel slide over the mechanism increasing the number of seats available.





TRINITY



Tavolo da pranzo allungabile, struttura in metallo, piano in nobilitato o ceramica e prolunga interna a libro.

Table de repas extensible avec une rallonge intégrée, structure en métal et plateau en mélamine ou céramique.

Metal frame extending dining table, top in melamine or ceramic, inside folded extension. Under-base wheels.

FINITURE PIANO FINITIONS PLATEAU TOP FINISHES

NOBILITATO / MÉLAMINE / MELAMINE

N20	Natural halifax oak
N23	Cemento
N24	Ardesia
N25	Vintage chiaro
N30	Morera
N33	Resina silver
N34	Resina grigio cenere
N35	Rovere nodato caramel
N36	Olmo moka
N40	Noce Canaletto
N42	Rovere nero
N43	Bianco spatolato
N44	Bianco statuario venato
N45	Diamond cream
N46	Pietra grey

CERAMICA / CÉRAMIQUE / CERAMIC

K01	Fokos Sale
K02	Fokos Terra
K03	Fokos Piombo
K04	Noir Desir lucido
K05	Bianco Statuario venato lucido
K06	Diamond Cream lucido
K07	Pietra Grey lucida
K09	Oxide Nero
K10	Oxide Bianco
K11	Pietra Savoia Antracite
K12	Pietra di Savoia Perla
K13	Calacatta Gold lucido
K14	Emperador lucido
K15	Noir Desir opaco
K16	Pietra Grey opaco
K17	Calacatta Gold opaco
K18	Bianco Statuario venato opaco
K19	Diamond Cream opaco
K20	Emperador opaco

LAMINAM
SUPERIOR NATURAL SURFACES

FINITURE BASE FINITIONS PIÉTEMENT BASE FINISHES

METALLO / MÉTAUX / METALS

M02	Vernic. grisou goffrato
M04	Vernic. nero opaco
M11	Vernic. grafite goffrato
M12	Vernic. tortora opaco
M19	Vernic. bronzo goffrato
M24	Vernic. bianco goffrato

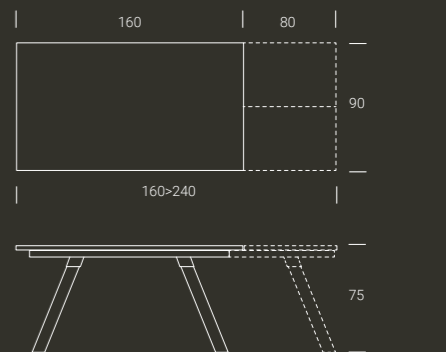
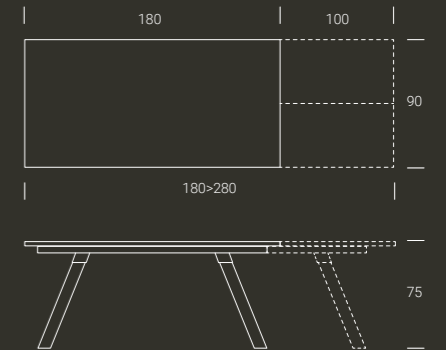

CELSIUS

IL TAVOLO CIRCOLARE CELSIUS SI ALLUNGA E DIVENTA OVALE SENZA PERDERE IL SUO FASCINO. LO SPESSORE INCLINATO SOTTO AL PIANO FA SCIVOLARE LO SGUARDO VERSO IL SOSTEGNO CENTRALE CHE CON UN EFFETTO DINAMICO ARREDA SPAZI IN CONTINUA EVOLUZIONE.

La table ronde Celsius s'allonge et devient ovale sans perdre son charme. La ceinture inclinée au-dessous du plateau se décline avec le piétement central, qui, avec son style dynamique, décore des espaces en constante évolution.

The round table Celsius extends and become oval without losing its charm. The tilted thickness under the top makes your sight slip through the central support that furnish the continuously evolving space with a dynamic effect.





CELSIUS

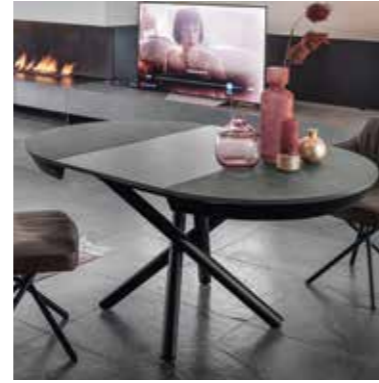

Tavolo da pranzo allungabile, struttura in metallo, meccanismo telescopico, piano in nobilitato, vetro, legno, effetto malta o ceramica. Apertura sincronizzata con prolunga interna a libro.

Table de repas avec rallonge intégrée porte-feuille, ouverture synchronisée, structure en métal, plateau mélamine, verre, bois, effet béton ou céramique.

Extending dining table with telescopic mechanism, metal frame, top in melamine, glass, wood, mortar-look or ceramic. Synchronized opening with inside folded extension.

FINITURE PIANO FINITIONS PLATEAU TOP FINISHES

NOBILITATO / MÉLAMINE / MELAMINE

N20	Natural halifax oak
N23	Cemento
N24	Ardesia
N25	Vintage chiaro
N30	Morera
N33	Resina silver
N34	Resina grigio cenere
N35	Rovere nodato caramel
N36	Olmo moka
N40	Noce Canaletto
N42	Rovere nero
N43	Bianco spatolato
N44	Bianco statuario venato
N45	Diamond cream
N46	Pietra grey

LACCATO / LAQUÉ / LACQUERED

Poro aperto / Pores ouverts / Open pore

L31	Bianco luce
L32	Bianco panna
L33	Bianco vela
L34	Grigio corda
L35	Grigio canapa
L39	Rosso aragosta
L40	Tortora

LEGNO IMPIALLACCIATO / PLACAGE BOIS / VENEER WOOD

W02	Rovere grigio
W03	Rovere tabacco
W04	Rovere nodato
W06	Rovere juta
W07	Rovere fumé
W10	Noce Canaletto

VETRO / VERRE / GLASS

G01	Bianco lucido
G02	Tortora lucido
G03	Nero lucido
G04	Bianco acidato
G05	Tortora acidato
G06	Nero acidato

EFFETTO MALTA / EFFET-BÉTON / MORTAR-LOOK

E04	Metalli vissuti nichel
E06	Beton tortora
E07	Beton nero
E08	Beton grigio scuro
E09	Beton grigio chiaro
E15	Pietra spatolata travertino metallizzato bianco
E19	Bianco assoluto
E20	Gros carruba
E21	Gros ciocco
E22	Ruggine
E23	Rock silver
E24	Rock copper
E25	Rock cemento

CERAMICA / CÉRAMIQUE / CERAMIC

K01	Fokos Sale
K02	Fokos Terra
K03	Fokos Piombo
K04	Noir Desir lucido
K05	Bianco Stuario venato lucido
K06	Diamond Cream lucido
K07	Pietra Grey lucida
K09	Oxide Nero
K10	Oxide Bianco
K11	Pietra Savoia Antracite
K12	Pietra di Savoia Perla
K13	Calacatta Gold lucido
K14	Emperador lucido
K15	Noir Desir opaco
K16	Pietra Grey opaco
K17	Calacatta Gold opaco
K18	Bianco Stuario venato opaco
K19	Diamond Cream opaco
K20	Emperador opaco

FINITURE BASE FINITIONS PIÉTEMENT BASE FINISHES

METALLO / MÉTAUX / METALS

M02	Verniciato Grisou goffrato
M04	Verniciato Nero opaco
M11	Verniciato Grafite goffrato
M12	Verniciato Tortora opaco
M19	Verniciato Bronzo goffrato
M24	Verniciato Bianco goffrato

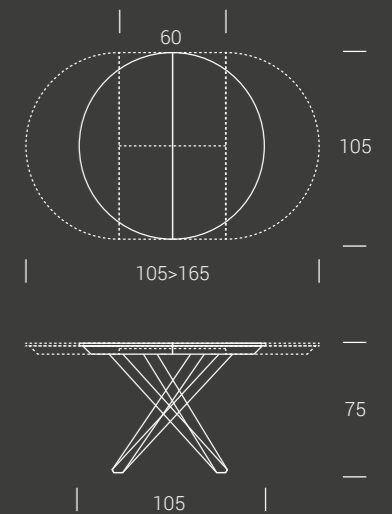

FAHRENHEIT ROUND

CON IL SUO PIANO ROTONDO SOSTENUTO DA BASE INTRECCIATA IN METALLO, FAHRENHEIT ROUND EVOCA L'ANTICO GIOCO DI SHANGHAI NEL QUALE L'UNICA MOSSA SI EPRIME NEL MOVIMENTO DEL PIANO CHE DILATA LA SUA FORMA ATTRAVERSO LA PROLUNGA INTERNA A LIBRO PER DEDICARSI ALLA CONVIVIALITÀ IN TUTTA LA SUA ESUBERANZA. FAHRENHEIT ROUND, UN GIOCO DI STILE FIRMATO ALTACOM.

Avec son plateau rond et son piétement tressé en métal, Fahrenheit Round évoque l'ancien jeu Shanghai, dans lequel le seul truc est le mouvement du plateau et de sa rallonge portefeuille. Fahrenheit Round, un jeu de style signé par Altacom.

With its round top and intertwined metal base, Fahrenheit Round evokes the ancient game of Shanghai, in which the only possible move is expressed through the movement of the top and its book extension. Fahrenheit Round, a classy game signed Altacom.



FAHRENHEIT ROUND



FAHRENHEIT ROUND



**Tavolo da pranzo allungabile,
struttura in metallo,
meccanismo telescopico, piano
in nobilitato, vetro, legno,
effetto malta o ceramica,
prolunga interna a libro.**

Table de repas avec rallonge intégrée
porte-feuille, structure en métal,
plateau mélamine, verre, bois, effet
béton ou céramique, mécanisme
télescopique.

Extending dining table with telescopic
mechanism, metal frame, top in
melamine, glass, wood, mortar-look or
ceramic, inside folded extension.

FINITURE PIANO FINITIONS PLATEAU TOP FINISHES

NOBILITATO / MÉLAMINE / MELAMINE

N20	Natural halifax oak
N23	Cemento
N24	Ardesia
N25	Vintage chiaro
N30	Morera
N33	Resina silver
N34	Resina grigio cenere
N35	Rovere nodato caramél
N36	Olmo moka
N40	Noce Canaletto
N42	Rovere nero
N43	Bianco spatolato
N44	Bianco statuario venato
N45	Diamond cream
N46	Pietra grey

LACCATO / LAQUÉ / LACQUERED

Poro aperto / Pores ouverts / Open pore

L31	Bianco luce
L32	Bianco panna
L33	Bianco vela
L34	Grigio corda
L35	Grigio canapa
L39	Rosso aragosta
L40	Tortora

LEGNO IMPIALLACCIATO / PLACAGE BOIS / VENEER WOOD

W02	Rovere grigio
W03	Rovere tabacco
W04	Rovere nodato
W06	Rovere juta
W07	Rovere fumé
W10	Noce Canaletto

VETRO / VERRE / GLASS

G01	Bianco lucido
G02	Tortora lucido
G03	Nero lucido
G04	Bianco acidato
G05	Tortora acidato
G06	Nero acidato

EFFETTO MALTA / EFFET-BÉTON / MORTAR-LOOK

E04	Metalli vissuti nichel
E06	Beton tortora
E07	Beton nero
E08	Beton grigio scuro
E09	Beton grigio chiaro
E15	Pietra spatolata travertino metallizzato bianco
E19	Bianco assoluto
E20	Gros carruba
E21	Gros ciocco
E22	Ruggine
E23	Rock silver
E24	Rock copper
E25	Rock cemento

CERAMICA / CÉRAMIQUE / CERAMIC

K01	Fokos Sale
K02	Fokos Terra
K03	Fokos Piombo
K04	Noir Desir lucido
K05	Bianco Statuario venato lucido
K06	Diamond Cream lucido
K07	Pietra Grey lucida
K09	Oxide Nero
K10	Oxide Bianco
K11	Pietra Savoia Antracite
K12	Pietra di Savoia Perla
K13	Calacatta Gold lucido
K14	Emperador lucido
K15	Noir Desir opaco
K16	Pietra Grey opaco
K17	Calacatta Gold opaco
K18	Bianco Statuario venato opaco
K19	Diamond Cream opaco
K20	Emperador opaco

FINITURE BASE FINITIONS PIÉTEMENT BASE FINISHES

METALLO / MÉTAUX / METALS

M02	Verniciato grisou gofrato
M04	Verniciato nero opaco
M11	Verniciato grafite gofrato
M12	Verniciato tortora opaco
M19	Verniciato bronzo gofrato
M24	Verniciato bianco gofrato

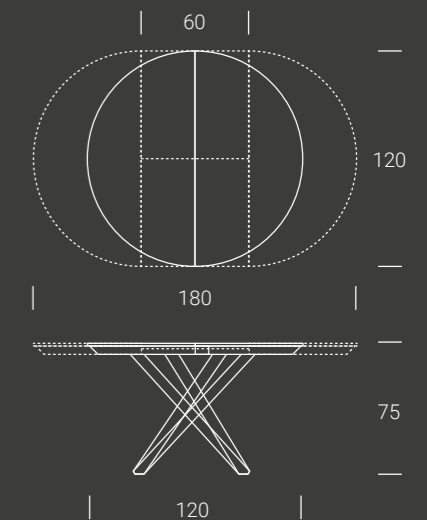

SUN, NELLA SUA FORMA A CALICE, EVOCA UNA COPPA DI CHAMPAGNE: IN EFFETTI QUESTO TAVOLO HA TUTTA L'ARIA DI VOLER FESTEggiARE IL CONNUBIO VINCENTE TRA RAFFINATEZZA E SINUOSITÀ DI UN DESIGN EVOLUTO E LA RICERCATEZZA DEL MATERIALE DEL PIANO IN CERAMICA PIETRA GREY OPACO. DOMINA AL CENTRO DELLA SALA, ACCOGLIENTE NELLA SUA ROTONDITÀ, DIVENTA ELLITTICO PER OFFRIRSI NELLE SUE PERFORMACES DIMENSIONALI.

Sun, dans sa forme "tulipe", évoque un verre de champagne: en fait, cette table a l'air de vouloir fêter l'union gagnante entre l'élégance et la sinuosité d'un design avancé et, également, avec le raffinement du matériel du plateau, la céramique pietra grey opaco. Dominante au centre de la pièce, accueillante dans sa rondeur, elle devient elliptique pour s'offrir dans ses performaces dimensionnelles.

Sun, in its "tulipe" shape, evokes a cup of champagne. In fact this table seems to be ready to celebrate the winning marriage between the sophistication and the sinuosity of an evolved design and the refinement of the material of the top, the pietra grey opaco ceramic. Dominant in the middle of the room, welcoming in its roundness, it becomes elliptical to offer itself in its dimensional performances.



Base/Piètement/Base: verniciato grafite goffrato M11
Piano/Plateau/Top: ceramica pietra grey opaco K16

SUN







**Tavolo da pranzo allungabile,
struttura in metallo,
meccanismo telescopico, piano
in nobilitato, vetro, legno,
effetto malta o ceramica,
prolunga interna a libro.**

porte-feuille, structure en métal,
plateau mélamine, verre, bois, effet
béton ou céramique, mécanisme
télescopique.

mechanism, metal frame, top in
melamine, glass, wood, mortar-look or
ceramic, inside folded extension.

Table de repas avec rallonge intégrée

Extending dining table with telescopic

FINITURE PIANO FINITIONS PLATEAU TOP FINISHES

NOBILITATO / MÉLAMINE / MELAMINE

N20	Natural halifax oak
N23	Cemento
N24	Ardesia
N25	Vintage chiaro
N30	Morera
N33	Resina silver
N34	Resina grigio cenere
N35	Rovere nodato caramel
N36	Olmo moka
N40	Noce Canaletto
N42	Rovere nero
N43	Bianco spatolato
N44	Bianco statuario venato
N45	Diamond cream
N46	Pietra grey

LACCATO / LAQUÉ / LACQUERED

Poro aperto / Pores ouverts / Open pore

L31	Bianco luce
L32	Bianco panna
L33	Bianco vela
L34	Grigio corda
L35	Grigio canapa
L39	Rosso aragosta
L40	Tortora

LEGNO IMPIALLACCIATO / PLACAGE BOIS / VENEER WOOD

W02	Rovere grigio
W03	Rovere tabacco
W04	Rovere nodato
W06	Rovere juta
W07	Rovere fumé
W10	Noce Canaletto

VETRO / VERRE / GLASS

G01	Bianco lucido
G02	Tortora lucido
G03	Nero lucido
G04	Bianco acidato
G05	Tortora acidato
G06	Nero acidato

EFFETTO MALTA / EFFET-BÉTON / MORTAR-LOOK

E04	Metalli vissuti nichel
E06	Beton tortora
E07	Beton nero
E08	Beton grigio scuro
E09	Beton grigio chiaro
E15	Pietra spatolata travertino metallizzato bianco
E19	Bianco assoluto
E20	Gros carruba
E21	Gros ciocco
E22	Ruggine
E23	Rock silver
E24	Rock copper
E25	Rock cemento

CERAMICA / CÉRAMIQUE / CERAMIC

K01	Fokos Sale
K02	Fokos Terra
K03	Fokos Piombo
K04	Noir Desir lucido
K05	Bianco Statuario venato lucido
K06	Diamond Cream lucido
K07	Pietra Grey lucida
K09	Oxide Nero
K10	Oxide Bianco
K11	Pietra Savoia Antracite
K12	Pietra di Savoia Perla
K13	Calacatta Gold lucido
K14	Emperador lucido
K15	Noir Desir opaco
K16	Pietra Grey opaco
K17	Calacatta Gold opaco
K18	Bianco Statuario venato opaco
K19	Diamond Cream opaco
K20	Emperador opaco

FINITURE BASE FINITIONS PIÉTEMENT BASE FINISHES

METALLO / MÉTAUX / METALS

M02	Verniciato grisou goffrato
M04	Verniciato nero opaco
M11	Verniciato grafite goffrato
M12	Verniciato tortora opaco
M19	Verniciato bronzo goffrato
M24	Verniciato bianco goffrato

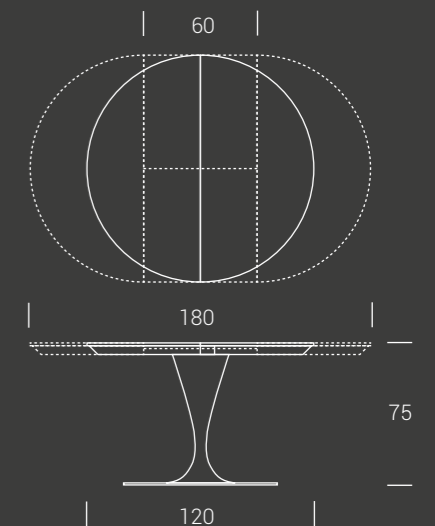

GIADA

IL SOTTILE SPESSORE DELLA CERAMICA IN SUPERFICIE DONA LEGGEREZZA AL PIANO, CHE SI APRE AL CENTRO PER ALLUNGARSI. CON LE SUE FORME SIMMETRICHE, IL TAVOLO DA PRANZO GIADA, CONQUISTA LA SCENA ED ARREDA CREANDO UN EQUILIBRIO ESTETICO SENZA EGUALI.

La petite épaisseur de la céramique donne de la légèreté au plateau, qui s'ouvre au milieu pour s'agrandir. Grâce à sa symétrie, la table de repas Giada est le personnage principal du décor, pour une balance esthétique sans précédent.

The thin thickness of the ceramic surface gives the top lightness. With its symmetric shape, dining table Giada conquers the scene and decorates creating unparalleled aesthetic balance.



GIADA







Tavolo da pranzo allungabile, struttura in metallo, piano in nobilitato o ceramica. Prolunga interna a libro.

Table de repas extensible avec une rallonge intégrée, structure en métal, plateau mélamine ou céramique.

Metal frame extending dining table, melamine or ceramic top, inside folded extension.

FINITURE PIANO
FINITIONS PLATEAU
TOP FINISHES

NOBILITATO
/ MÉLAMINE
/ MELAMINE

- N20 Natural halifax oak
- N23 Cemento
- N24 Ardesia
- N25 Vintage chiaro
- N30 Morera
- N33 Resina silver
- N34 Resina grigio cenere
- N35 Rovere nodato caramel
- N36 Olmo moka
- N40 Noce Canaletto
- N42 Rovere nero
- N43 Bianco spatolato
- N44 Bianco statuario venato
- N45 Diamond cream
- N46 Pietra grey

CERAMICA
/ CÉRAMIQUE
/ CERAMIC

- K01 Fokos Sale
- K02 Fokos Terra
- K03 Fokos Piombo
- K04 Noir Desir lucido
- K05 Bianco Statuario venato lucido
- K06 Diamond Cream lucido
- K07 Pietra Grey lucida
- K09 Oxide Nero
- K10 Oxide Bianco
- K11 Pietra Savoia Antracite
- K12 Pietra di Savoia Perla
- K13 Calacatta Gold lucido
- K14 Emperador lucido
- K15 Noir Desir opaco
- K16 Pietra Grey opaco
- K17 Calacatta Gold opaco
- K18 Bianco Statuario venato opaco
- K19 Diamond Cream opaco
- K20 Emperador opaco

LAMINAM
SUPERIOR NATURAL SURFACES

FINITURE BASE
FINITIONS PIÉTEMENT
BASE FINISHES

METALLO
/ MÉTAUX
/ METALS

- M02 Vern. Grisou gofrato
- M04 Vern. Nero opaco
- M11 Vern. Grafite gofrato
- M12 Vern. Tortora opaco
- M19 Vern. Bronzo gofrato
- M24 Vern. Bianco gofrato

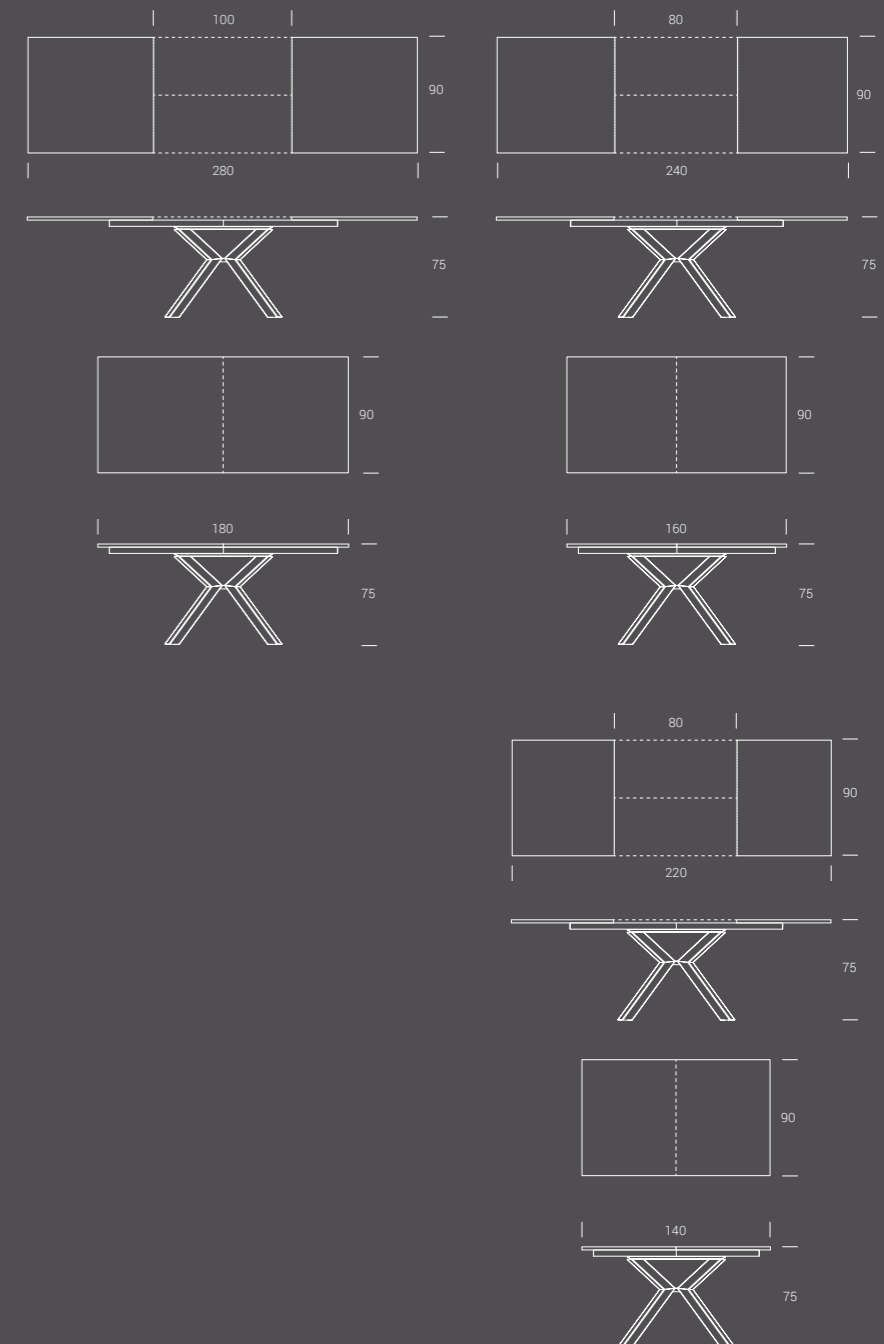

FAHRENHEIT

FAHRENHEIT SI ESPRIME ATTRAVERSO LA SUA SINGOLARE STRUTTURA AD INTRECCIO IN METALLO, INCONFONDIBILE NEL DESIGN, ESPANDIBILE NELLA SUA VERSIONE ALLUNGATA. IL PIANO AD ALTO SPESSORE È ANCH'ESSO UN ELEMENTO CARATTERIZZANTE COME IN QUESTA VERSIONE IN NOBILITATO ARDESIA, E SI STAGLIA IN CENTRO STANZA COME UN'OPERA SCULTOREA CONTEMPORANEA.

Fahrenheit s' exprime à travers son originale structure à entrelacement de métal, inimitable dans le design, extensible dans sa version étendue. Le plateau de forte épaisseur est également un ingrédient qui la caractérise, comme dans cette version en mélaminé ardoise, et elle se démarque au milieu de la pièce comme une oeuvre de sculpture contemporaine.

Fahrenheit expresses itself through its original structure by a plot of metal, unique in design, expandable in its extended version. The high thickness top is also a characteristic element as in this version in ardesia melamine, and stands out in the middle of the room as a contemporary scultory work.







FAHRENHEIT



FINITURE PIANO FINITIONS PLATEAU TOP FINISHES

NOBILITATO / MÉLAMINE / MELAMINE

N20	Natural halifax oak
N23	Cemento
N24	Ardesia
N25	Vintage chiaro
N30	Morera
N33	Resina silver
N34	Resina grigio cenere
N35	Rovere nodato caramel
N36	Olmo moka
N40	Noce Canaletto
N42	Rovere nero
N43	Bianco spatolato
N44	Bianco statuario venato
N45	Diamond cream
N46	Pietra grey

LACCATO / LAQUÉ / LACQUERED

Poro aperto / Pores ouverts / Open pore

L31	Bianco luce
L32	Bianco panna
L33	Bianco vela
L34	Grigio corda
L35	Grigio canapa
L39	Rosso aragosta
L40	Tortora

LEGNO IMPIALLACCIATO / PLACAGE BOIS / VENEER WOOD

W02	Rovere grigio
W03	Rovere tabacco
W04	Rovere nodato
W06	Rovere juta
W07	Rovere fumé
W10	Noce Canaletto

EFFETTO MALTA / EFFET-BÉTON / MORTAR-LOOK

E04	Metalli vissuti nichel
E06	Beton tortora
E07	Beton nero
E08	Beton grigio scuro
E09	Beton grigio chiaro
E15	Pietra spatolata travertino metallizzato bianco
E19	Bianco assoluto
E20	Gros carruba
E21	Gros ciocco
E22	Ruggine
E23	Rock silver
E24	Rock copper
E25	Rock cemento

Tavolo da pranzo fisso, struttura in metallo, piano in nobilitato o legno bordo corteccia.

Table de repas fixe structure en métal, plateau mélamine ou bois chants écorce.

Fixed dining table with metal frame, top in melamine or wood with bark edges.

Tavolo da pranzo allungabile, struttura in metallo, piano in nobilitato, legno bordo corteccia o effetto malta, 2 prolunghe interne.

Table de repas extensible avec 2 rallonges intégrées, structure en métal, plateau mélamine, bois chants écorce ou effet-béton.

Metal frame extending dining table, top in melamine, wood with bark edges or mortar-look, 2 inside extensions.

FINITURE BASE FINITIONS PIÉTEMENT BASE FINISHES

METALLO / MÉTAUX / METALS

M02	Verniciato grisou goffrato
M04	Verniciato nero opaco
M11	Verniciato grafite goffrato
M12	Verniciato tortora opaco
M19	Verniciato bronzo goffrato
M24	Verniciato bianco goffrato

ALLUNGABILE EXTENSIBLE / EXTENDABLE

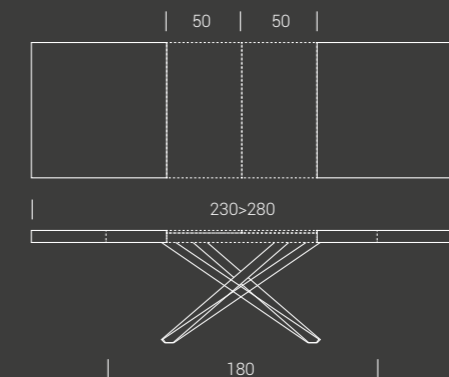
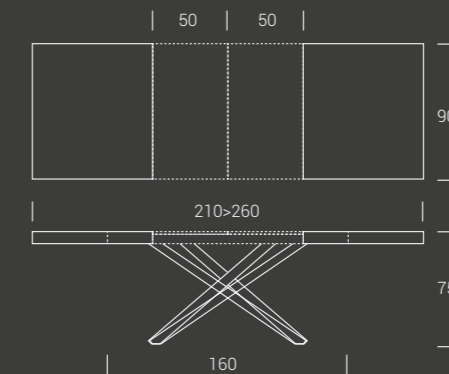

FISSO FIXE / FIXED

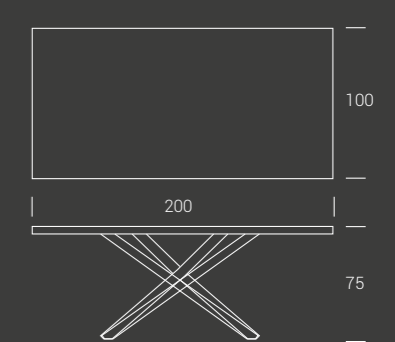
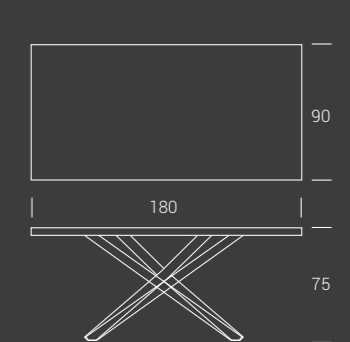

MERIDIANO

MERIDIANO SI ISPIRA ALLA NATURA CHE PER NULLA INVADENTE ENTRA NELLE NOSTRE CASE CON FORME INGENTILITE DALLA MANO DELL'ARTIGIANO PER RENDERE CONFORTEVOLE E BELLO IL NOSTRO HABITAT. UN PIANO IN ROVERE NODATO CON BORDI EFFETTO CORTECCIA SEMBRA ESSERE SENZA PESO PER EFFETTO DELLA STRUTTURA DI SOSTEGNO IN VETRO TRASPARENTE. MERIDIANO "UNA FORZA DELLA NATURA".

Meridiano s'inspire à la nature qui, pas du tout envahissante, rentre dans nos maisons avec des formes adoucies par la main de l'artisan pour rendre confortable et beau notre habitat. Un plateau en chêne noueux avec les chants en effet-écorce paraît n'avoir pas de poids grâce à la structure de support en verre transparent. Meridiano « une force de la nature ».

Meridiano is inspired by nature which, not at all invasive, enters our homes with the shapes softened by the craftsman's hand to make our habitat comfortable and beautiful. A wild oak top with bark-edges seems to be weightless thanks to the structure in transparent glass. Meridiano "a force of nature".



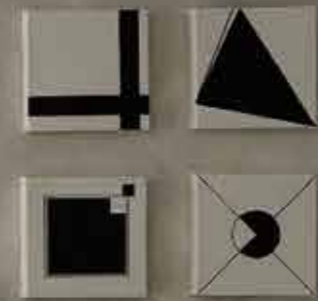

MERIDIANO



FINITURE PIANO FINITIONS PLATEAU TOP FINISHES

NOBILITATO / MÉLAMINE / MELAMINE

N20	Natural halifax oak
N23	Cemento
N24	Ardesia
N25	Vintage chiaro
N30	Morera
N33	Resina silver
N34	Resina grigio cenere
N35	Rovere nodato caramel
N36	Olmo moka
N40	Noce Canaletto
N42	Rovere nero
N43	Bianco spatolato
N44	Bianco statuario venato
N45	Diamond cream
N46	Pietra grey

LACCATO / LAQUÉ / LACQUERED

Poro aperto / Pores ouverts / Open pore

L31	Bianco luce
L32	Bianco panna
L33	Bianco vela
L34	Grigio corda
L35	Grigio canapa
L39	Rosso aragosta
L40	Tortora

LEGNO IMPIALLACCIATO / PLACAGE BOIS / VENEER WOOD

W02	Rovere grigio
W03	Rovere tabacco
W04	Rovere nodato
W06	Rovere juta
W07	Rovere fumé
W10	Noce Canaletto

EFFETTO MALTA / EFFET-BÉTON / MORTAR-LOOK

E04	Metalli vissuti nichel
E06	Beton tortora
E07	Beton nero
E08	Beton grigio scuro
E09	Beton grigio chiaro
E15	Pietra spatolata travertino metallizzato bianco
E19	Bianco assoluto
E20	Gros carruba
E21	Gros ciocco
E22	Ruggine
E23	Rock silver
E24	Rock copper
E25	Rock cemento

**Tavolo da pranzo fisso,
struttura in metallo, piano
in nobilitato o legno bordo
corteccia.**

**Tavolo da pranzo allungabile,
gambe in vetro trasparente,
piano in nobilitato, legno bordo
corteccia o effetto malta,
2 prolunghe interne.**

Table de repas fixe structure
en métal, plateau mélamine ou bois
chants écorce.

Table de repas extensible avec
2 rallonges intégrées, piétement en
verre transparent, plateau mélamine,
bois chants écorce ou effet-béton.

Fixed dining table with metal frame,
top in melamine or wood with
bark edges.

Transparent glass legs extending
dining table, top in melamine, wood
with bark edges or mortar-look, 2
inside extensions.

FINITURE BASE FINITIONS PIÉTEMENT BASE FINISHES

VETRO / VERRE / GLASS

Vetro trasparente

ALLUNGABILE EXTENSIBLE / EXTENDABLE

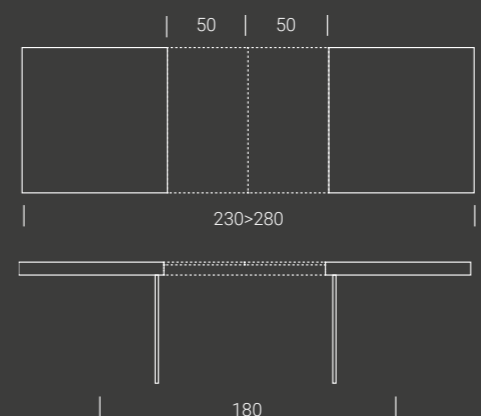
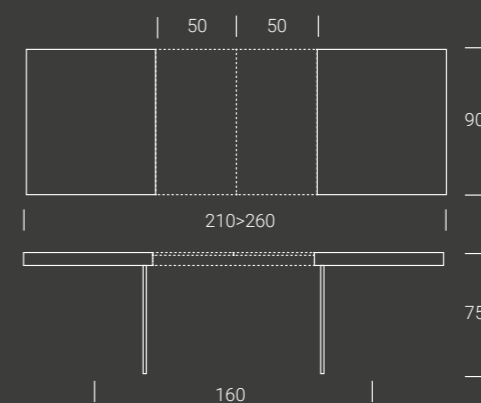

FISSO FIXE / FIXED

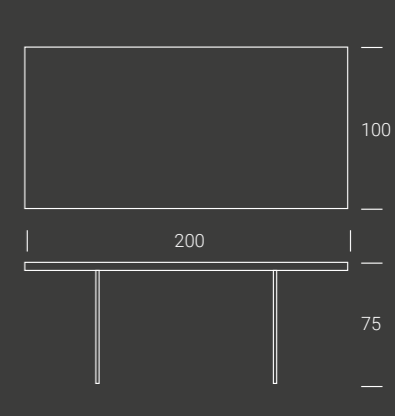
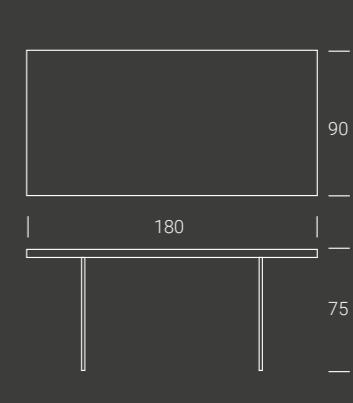

R I B O T

PRATICO E VERSATILE, RIBOT PUÒ ESSERE TEATRO DI ROMANTICHE CENE O DIVENTARE PROTAGONISTA IN POCHI Istanti DI PRANZI CON AMICI. CHI DICE CHE I PICCOLI SPAZI NON POSSANO AVERE GRANDI TAVOLI, NON HA ANCORA INCONTRATO RIBOT.

Pratique et versatile, Ribot peut faire la joie de repas romantiques et en quelques instants peut être la protagoniste pour des repas entre amis. Ces qui disent que les petits espaces ne peuvent pas accueillir de grandes tables, ils n'ont pas encore rencontré Ribot.

Practical and versatile, Ribot can be the theatre of romantic dinners, or becoming easily the main character of a lunch with friends. The ones who say that small spaces can't have big tables haven't met Ribot yet.



RIBOT



RIBOT



RIBOT



FINITURE PIANO FINITIONS PLATEAU TOP FINISHES

NOBILITATO / MÉLAMINE / MELAMINE

N20	Natural halifax oak
N23	Cemento
N24	Ardesia
N25	Vintage chiaro
N30	Morera
N33	Resina silver
N34	Resina grigio cenere
N35	Rovere nodato caramel
N36	Olmo moka
N40	Noce Canaletto
N42	Rovere nero
N43	Bianco spatolato
N44	Bianco statuario venato
N45	Diamond cream
N46	Pietra grey

LACCATO / LAQUÉ / LACQUERED

Poro aperto / Pores ouverts / Open pore	Opaco / Mat / Matt	
L31	L51	Bianco luce
L32	L52	Bianco panna
L33	L53	Bianco vela
L34	L54	Grigio corda
L35	L55	Grigio canapa
L39	L59	Rosso aragosta
L40	L60	Tortora

LEGNO IMPIALLACCIATO / PLACAGE BOIS / VENEER WOOD

W02	Rovere grigio
W03	Rovere tabacco
W04	Rovere nodato
W06	Rovere juta
W07	Rovere fumé
W10	Noce Canaletto

EFFETTO MALTA / EFFET-BÉTON / MORTAR-LOOK

E04	Metalli vissuti nichel
E06	Beton tortora
E07	Beton nero
E08	Beton grigio scuro
E09	Beton grigio chiaro
E15	Pietra spatolata travertino metallizzato bianco
E19	Bianco assoluto
E20	Gros carruba
E21	Gros ciocco
E22	Ruggine
E23	Rock silver
E24	Rock copper
E25	Rock cemento

CERAMICA / CÉRAMIQUE / CERAMIC

K01	Fokos Sale
K02	Fokos Terra
K03	Fokos Piombo
K04	Noir Desir lucido
K05	Bianco Statuario venato lucido
K06	Diamond Cream lucido
K07	Pietra Grey lucida
K09	Oxide Nero
K10	Oxide Bianco
K11	Pietra Savoia Antracite
K12	Pietra di Savoia Perla
K13	Calacatta Gold lucido
K14	Emperador lucido
K15	Noir Desir opaco
K16	Pietra Grey opaco
K17	Calacatta Gold opaco
K18	Bianco Statuario venato opaco
K19	Diamond Cream opaco
K20	Emperador opaco

Tavolo da pranzo, struttura allungabile in metallo, meccanismo telescopico, piano in nobilitato, legno, effetto malta o ceramica. Prolunga interna a libro.

Table de repas, structure extensible en métal, plateau mélamine, bois, effet-béton ou céramique. Rallonge interne à portefeuille.

Metal frame dining table with telescopic extending mechanism, top in melamine, wood, ceramic or mortar-look. One folded extension.

FINITURE BASE FINITIONS PIÉTEMENT BASE FINISHES

METALLO / MÉTAUX / METALS

M02	Vern. Grisou goffrato
M04	Vern. Nero opaco
M11	Vern. Grafite goffrato
M12	Vern. Tortora opaco
M19	Vern. Bronzo goffrato
M24	Vern. Bianco goffrato

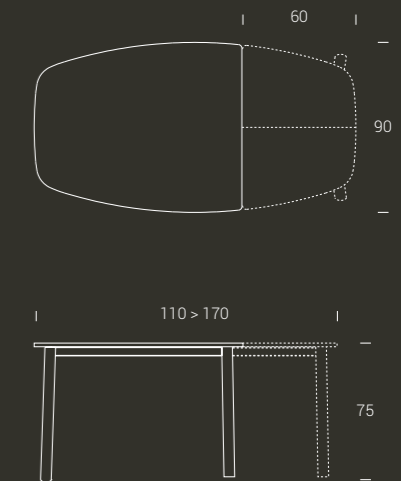

RIBOT WOOD

I TONI MORBIDI DELLE FINITURE IN LEGNO SCALDANO L'ASPETTO DI QUESTO TAVOLO, GIÀ ADDOLCITO NELLE FORME CURVE E PIACEVOLI, DONANDO ANCHE ATTRAVERSO IL TATTO UN'ESPERIENZA DI UTILIZZO GRADEVOLLE. RIBOT WOOD CONQUISTA COINVOLGENDO TUTTI I SENSI.

La souplesse des finitions en bois valorise l'aspect de cette table, caractérisée par ses lignes courbées et charmantes et agréable au toucher. Ribot Wood séduit en engageant tous les sens.

The smooth tones of the wooden finish warm the aspect of this table with already sweetened shapes, giving also through touch a pleasant user experience. Ribot Wood conquers involving all senses.



Base/Piédement/Base:
rovere grigio W02

Piano/Plateau/Top:
rovere grigio W02

Sedia JOLIE
metallo verniciato M11
e rovere grigio W02

RIBOT WOOD



RIBOT WOOD



RIBOT WOOD
design Toshiyuki Yoshino

RIBOT WOOD



FINITURE PIANO FINITIONS PLATEAU TOP FINISHES

LEGNO IMPIALLACCIATO / PLACAGE BOIS / VENEER WOOD

- W02 Rovere grigio
- W03 Rovere tabacco
- W04 Rovere nodato
- W06 Rovere juta
- W07 Rovere fumé

- W10 Noce Canaletto

LACCATO / LAQUÉ / LACQUERED

Poro aperto / Pores ouverts / Open pore

- L31 Bianco luce
- L32 Bianco panna
- L33 Bianco vela
- L34 Grigio corda
- L35 Grigio canapa
- L39 Rosso aragosta
- L40 Tortora

CERAMICA / CÉRAMIQUE / CERAMIC

- K01 Fokos Sale
- K02 Fokos Terra
- K03 Fokos Piombo
- K04 Noir Desir lucido
- K05 Bianco Statuario venato lucido
- K06 Diamond Cream lucido
- K07 Pietra Grey lucida
- K09 Oxide Nero
- K10 Oxide Bianco
- K11 Pietra Savoia Antracite
- K12 Pietra di Savoia Perla
- K13 Calacatta Gold lucido
- K14 Emperador lucido
- K15 Noir Desir opaco
- K16 Pietra Grey opaco
- K17 Calacatta Gold opaco
- K18 Bianco Statuario venato opaco
- K19 Diamond Cream opaco
- K20 Emperador opaco

LAMINAM
SUPERIOR NATURAL SURFACES

FINITURE GAMBE FINITIONS PIEDS LEGS FINISHES

LEGNO IMPIALLACCIATO / PLACAGE BOIS / VENEER WOOD

- W02 Rovere grigio
- W03 Rovere tabacco
- W04 Rovere nodato
- W06 Rovere juta
- W07 Rovere fumé

- W10 Noce Canaletto

LACCATO / LAQUÉ / LACQUERED

Poro aperto / Pores ouverts / Open pore

- L31 Bianco luce
- L32 Bianco panna
- L33 Bianco vela
- L34 Grigio corda
- L35 Grigio canapa
- L39 Rosso aragosta
- L40 Tortora

Tavolo da pranzo, struttura
allungabile in metallo,
meccanismo telescopico, piano
in ceramica o in legno, gambe in
legno e prolunga interna a libro.

Table de repas, mécanisme
télescopique en métal, plateau en
céramique ou en bois, pieds en bois et
rallonge intégrée à portefeuille.

Dining table, telescopic extending
mechanism, top in ceramic or wood,
legs in wood and inside folded
extension.

FINITURE STRUTTURA FINITIONS STRUCTURE FRAME FINISHES

METALLO / MÉTAUX / METALS

- M11 Vern. Grafite goffrato

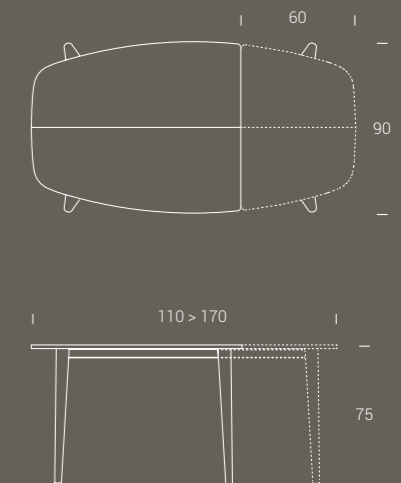

SIPARIO

SARÀ SOLO APRENDO IL "SIPARIO" CHE POTRAI SCOPRIRE LA MAESTOSITÀ DELL'OPERA CHE CELA AL SUO INTERNO. DALLE LINEE GEOMETRICHE ED ELEGANTI QUESTO TAVOLO DA PRANZO PUÒ ACCOGLIERE DA 4 A 8 PERSONE, TRASFORMANDOSI IN POCHE SEMPLICI MOSSE SEGUENDO LE TUE ESIGENZE, PER SCOPRIRE CHE I VERI PROTAGONISTI SIETE VOI.

Seulement en ouvrant sipario que vous pourrez découvrir ce majestueux chef d'œuvre qu'il englobe. Avec ses lignes géométriques et élégantes, cette table de repas peut accueillir de 4 à 8 personnes, elle se transforme avec de simples mouvements en suivant vos exigences, pour découvrir que vous êtes son maître.

It's only when you open the sipario that you can discover the majesty of the work it conceals inside. From the long, geometric, elegant lines the dining table can host from 4 to 8 people, transforming in few easy steps following your needs, to discover that you are the real key player.



SIPARIO







SIPARIO



Tavolo da pranzo allungabile, struttura in metallo, meccanismo telescopico, piano in nobilitato, legno o effetto malta, prolunga interna a libro.

Table de repas avec rallonge intégrée porte-feuille, structure en métal, plateau mélamine, bois ou effet-béton, mécanisme télescopique.

Extending dining table with telescopic mechanism, metal frame, top in melamine, wood or mortar-look, inside folded extension.

FINITURE PIANO FINITIONS PLATEAU TOP FINISHES

NOBILITATO / MÉLAMINE / MELAMINE

N20	Natural halifax oak
N23	Cemento
N24	Ardesia
N25	Vintage chiaro
N30	Morera
N33	Resina silver
N34	Resina grigio cenere
N35	Rovere nodato caramelo
N36	Olmo moka
N40	Noce Canaletto
N42	Rovere nero
N43	Bianco spatolato
N44	Bianco statuario venato
N45	Diamond cream
N46	Pietra grey

LACCATO / LAQUÉ / LACQUERED

Poro aperto / Pores ouverts / Open pore

L31	Bianco luce
L32	Bianco panna
L33	Bianco vela
L34	Grigio corda
L35	Grigio canapa
L39	Rosso aragosta
L40	Tortora

LEGNO IMPIALLACCIATO / PLACAGE BOIS / VENEER WOOD

W02	Rovere Grigio
W03	Rovere Tabacco
W04	Rovere Nodato
W06	Rovere Juta
W07	Rovere Fumé
W10	Noce Canaletto

EFFETTO MALTA / EFFET-BÉTON / MORTAR-LOOK

E04	Metalli vissuti nichel
E06	Beton tortora
E07	Beton nero
E08	Beton grigio scuro
E09	Beton grigio chiaro
E15	Pietra spatolata travertino metallizzato bianco
E19	Bianco assoluto
E20	Gros carruba
E21	Gros ciocco
E22	Ruggine
E23	Rock silver
E24	Rock copper
E25	Rock cemento

FINITURE BASE FINITIONS PIÉTEMENT BASE FINISHES

METALLO / MÉTAUX / METALS

M02	Vern. Grisou goffrato
M04	Vern. Nero opaco
M11	Vern. Grafite goffrato
M12	Vern. Tortora opaco
M19	Vern. Bronzo goffrato
M24	Vern. Bianco goffrato

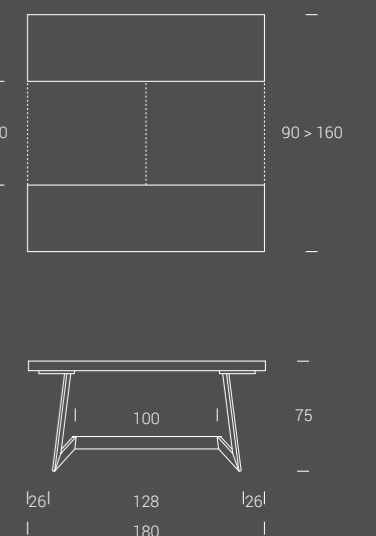
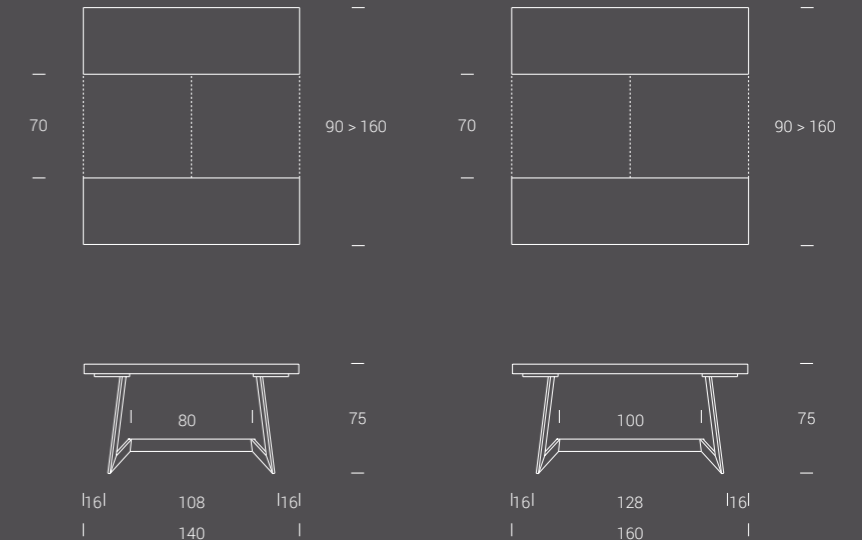

PICK - U P

UN TAVOLO DAL CARATTERE BEN DEFINITO, MA VARIABILE NELLA LUNGHEZZA: IL MECCANISMO INTERNO PERMETTE, CON UN FLUIDO SCORRIMENTO, DI ESTRARRE L'ALLUNGA E POSIZIONARLA IN POCHI ISTANTI. PER NON METTERE LIMITI ALL'OSPITALITÀ.

Une table au caractère bien défini, mais variable dans la longueur: la mécanique interne, avec un fluide glissement, permet de sortir la rallonge et la placer en quelques secondes. Une hospitalité sans aucune limite.

A table with a well-defined character but variable length: the internal mechanism allows with a fluid flow to extract the extension and position it in a minute.



PICK - U P



PICK - U P



PICK - UP



FINITURE PIANO FINITIONS PLATEAU TOP FINISHES

NOBILITATO / MÉLAMINE / MELAMINE

N20	Natural halifax oak
N23	Cemento
N24	Ardesia
N25	Vintage chiaro
N30	Morera
N33	Resina silver
N34	Resina grigio cenere
N35	Rovere nodato caramel
N36	Olmo moka
N40	Noce Canaletto
N42	Rovere nero
N43	Bianco spatolato
N44	Bianco statuario venato
N45	Diamond cream
N46	Pietra grey

Tavolo alto da pranzo / penisola, struttura allungabile in metallo, meccanismo telescopico, piano in nobilitato, prolunga interna a libro. Altezza fissa 102 cm.

Table haute de repas avec rallonge portefeuille intégrée, structure en métal, plateau melamine, mécanisme télescopique. Hauteur fixe 102 cm.

Counter height metal frame dining table with telescopic extending table with telescopic extending mechanism, top in melamine, inside folded extension. Fixed height 102 cm.

FINITURE BASE FINITIONS PIÉTEMENT BASE FINISHES

METALLO / MÉTAUX / METALS

M02	Vern. Grisou goffrato
M04	Vern. Nero opaco
M11	Vern. Grafite goffrato
M12	Vern. Tortora opaco
M19	Vern. Bronzo goffrato
M24	Vern. Bianco goffrato

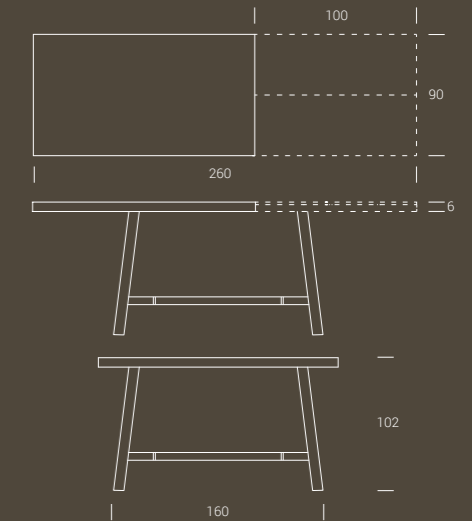
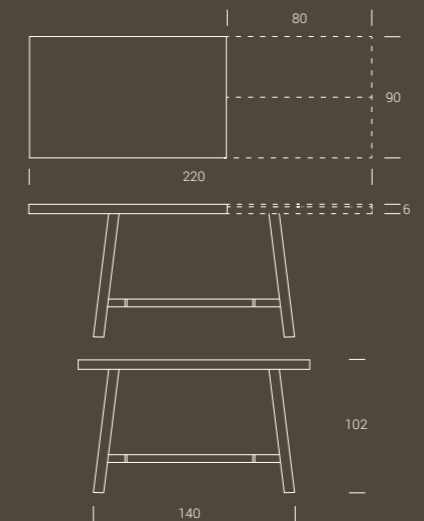
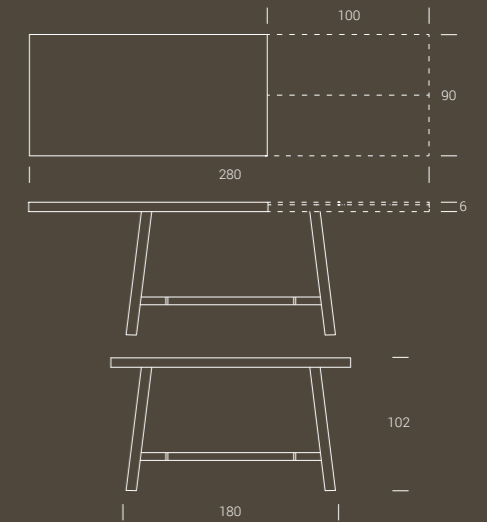

ARGON

LE GEOMETRIE RIGOROSE DELLA STRUTTURA IN NERO OPACO, SOTTOLINEANO IL CONTRASTO CON IL PIANO EFFETTO PIETRA DI QUESTO TAVOLO, PERFETTAMENTE EQUILIBRATO IN TUTTE LE SUE DIMENSIONI. COLLOCABILE NELL'AREA LIVING COME NELLE PIÙ MODERNE CUCINE ASSOLVE CON RAFFINATEZZA IL PROPRIO COMPITO DI OSPITE, CON GENEROSITÀ.

Les géométries rigoureuses de la structure en noir mat, mettent l'accent sur le contraste avec le plateau en effet-pierre de cette table, parfaitement équilibrée en toutes ses dimensions. Adaptable à tout living ainsi qu'à toute cuisine moderne, elle joue avec classe son rôle d'hôte, généreusement.

The rigorous geometries of the matt black structure emphasize the contrast with the stone-look top of this table, perfectly balanced in all its dimensions. Easygoing in any living area and in the most modern kitchens as well, it plays its host role with generosity.



ARGON





ARGON



FINITURE PIANO FINITIONS PLATEAU TOP FINISHES

NOBILITATO / MÉLAMINE / MELAMINE

N20	Natural halifax oak
N23	Cemento
N24	Ardesia
N25	Vintage chiaro
N30	Morera
N33	Resina silver
N34	Resina grigio cenere
N35	Rovere nodato caramel
N36	Olmo moka
N40	Noce Canaletto
N42	Rovere nero
N43	Bianco spatolato
N44	Bianco statuario venato
N45	Diamond cream
N46	Pietra grey

EFFETTO MALTA / EFFET-BÉTON / MORTAR-LOOK

E04	Metalli vissuti nichel
E06	Beton tortora
E07	Beton nero
E08	Beton grigio scuro
E09	Beton grigio chiaro
E15	Pietra spatolata travertino metallizzato bianco
E19	Bianco assoluto
E20	Gros carruba
E21	Gros ciocco
E22	Ruggine
E23	Rock silver
E24	Rock copper
E25	Rock cemento

Tavolo da pranzo, struttura allungabile in metallo, meccanismo telescopico, piano in nobilitato o effetto malta, 3 prolunghe interne.

Table de repas avec 3 rallonges intégrées, structure en métal, plateau mélamine ou effet-béton, mécanisme télescopique.

Metal frame dining table with telescopic extending mechanism, top in melamine and mortar-look, 3 inside extensions.

FINITURE BASE FINITIONS PIÉTEMENT BASE FINISHES

METALLO / MÉTAUX / METALS

M02	Verniciato grisou gofrato
M04	Verniciato nero opaco
M11	Verniciato grafite gofrato
M12	Verniciato tortora opaco
M19	Verniciato bronzo gofrato
M24	Verniciato bianco gofrato

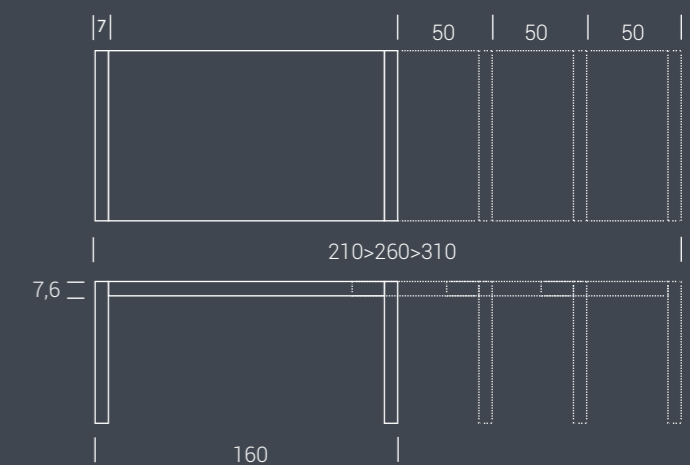
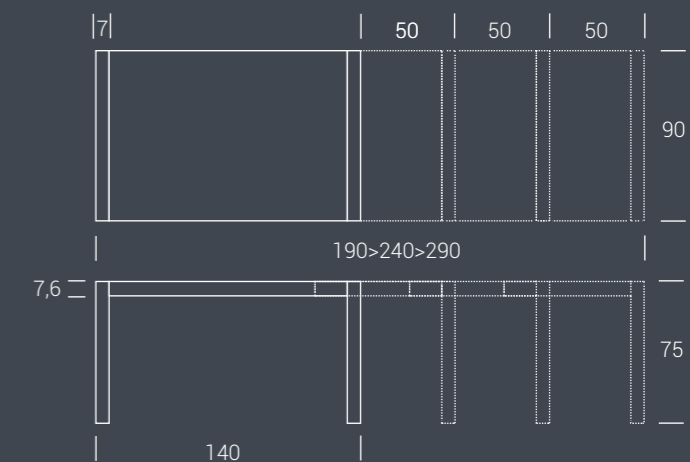

TEOREMA

LA CARATTERISTICA FORMA TRIANGOLARE DELLE GAMBE, REGALA UN'IMMAGINE DI ELEGANZA FORMALE CHE BEN SI PRESTA AD ARREDARE CONTESTI CONTEMPORANEI. LA TESI È QUELLA DI AVERE UN PIANO PER LE DIFFERENTI ESIGENZE ABITATIVE, E TEOREMA È LA RISPOSTA CONCRETA ALLA RICERCA DEL BELLO "FUNZIONALE".

La caractéristique forme triangulaire des pieds, donne une image d'élégance formelle qui se prête bien à aménager des contextes contemporains. L'idée est d'avoir un plateau pour chacune des différentes exigences d'habitat, et teorema est la réponse concrète à la recherche du beau « fonctionnel ».

The characteristic triangular shape of the legs, gives an image of formal elegance that is definitely open to furnish any contemporary context. The goal is to have a top for any different need of the habitat, and teorema is the concrete answer to the search of the "functional" beauty.







TEOREMA



Tavolo da pranzo, struttura allungabile in metallo, meccanismo telescopico, piano in nobilitato, legno, effetto malta, vetro o ceramica. Disponibile con meccanismo tradizionale e allunghe a libro o con meccanismo super allungabile con allunghe interne.

Table de repas, structure en métal, plateau mélamine, verre, bois, laqué, effet-béton ou céramique, mécanisme télescopique. Disponible avec mécanique traditionnel et rallonges porte-feuille, ou mécanique super-extensible avec rallonges intégrées.

Metal frame dining table with telescopic extending mechanism, top in melamine, glass, stained wood, mortar-look or ceramic. Available with traditional mechanism and book extensions or with super-extendable mechanism and inside extensions.

FINITURE PIANO FINITIONS PLATEAU TOP FINISHES

NOBILITATO / MÉLAMINE / MELAMINE

N20	Natural halifax oak
N23	Cemento
N24	Ardesia
N25	Vintage chiaro
N30	Morera
N33	Resina silver
N34	Resina grigio cenere
N35	Rovere nodato caramél
N36	Olmo moka
N40	Noce Canaletto
N42	Rovere nero
N43	Bianco spatolato
N44	Bianco statuario venato
N45	Diamond cream
N46	Pietra grey

LACCATO / LAQUÉ / LACQUERED

Poro aperto / Pores ouverts / Open pore

L31	Bianco luce
L32	Bianco panna
L33	Bianco vela
L34	Grigio corda
L35	Grigio canapa
L39	Rosso aragosta
L40	Tortora

LEGNO IMPIALLACCIATO / PLACAGE BOIS / VENEER WOOD

W02	Rovere grigio
W03	Rovere tabacco
W04	Rovere nodato
W06	Rovere juta
W07	Rovere fumé
W10	Noce Canaletto

VETRO / VERRE / GLASS

G01	Bianco lucido
G02	Tortora lucido
G03	Nero lucido
G04	Bianco acidato
G05	Tortora acidato
G06	Nero acidato

EFFETTO MALTA / EFFET-BÉTON / MORTAR-LOOK

E04	Metalli vissuti nichel
E06	Beton tortora
E07	Beton nero
E08	Beton grigio scuro
E09	Beton grigio chiaro
E15	Pietra spatolata travertino metallizzato bianco
E19	Bianco assoluto
E20	Gros carruba
E21	Gros ciocco
E22	Ruggine
E23	Rock silver
E24	Rock copper
E25	Rock cemento

CERAMICA / CÉRAMIQUE / CERAMIC

K01	Fokos Sale
K02	Fokos Terra
K03	Fokos Piombo
K04	Noir Desir lucido
K05	Bianco Staturario venato lucido
K06	Diamond Cream lucido
K07	Pietra Grey lucida
K09	Oxide Nero
K10	Oxide Bianco
K11	Pietra Savoia Antracite
K12	Pietra di Savoia Perla
K13	Calacatta Gold lucido
K14	Emperador lucido
K15	Noir Desir opaco
K16	Pietra Grey opaco
K17	Calacatta Gold opaco
K18	Bianco Staturario venato opaco
K19	Diamond Cream opaco
K20	Emperador opaco

FINITURE BASE FINITIONS PIÉTEMENT BASE FINISHES

METALLO / MÉTAUX / METALS

M02	Vern. grisou goffrato
M04	Vern. nero opaco
M11	Vern. grafite goffrato
M12	Vern. tortora opaco
M19	Vern. bronzo goffrato
M24	Vern. bianco goffrato

TEOREMA SUPER

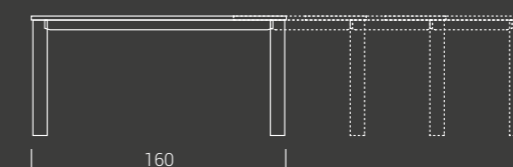
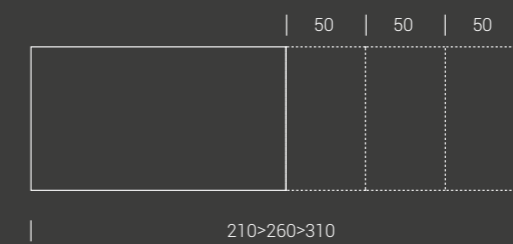
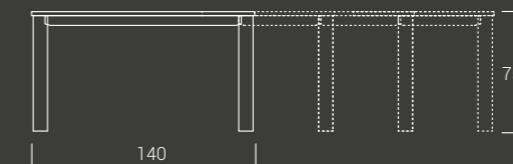
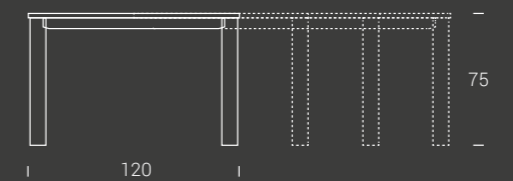
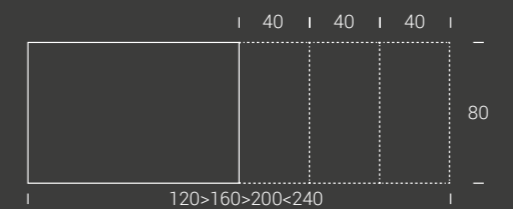

TEOREMA

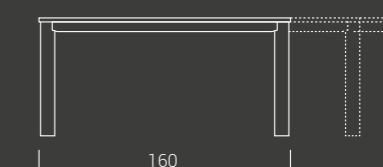
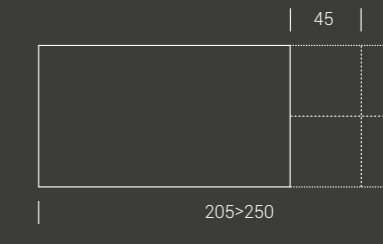
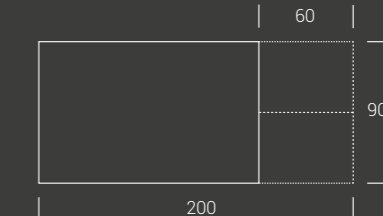
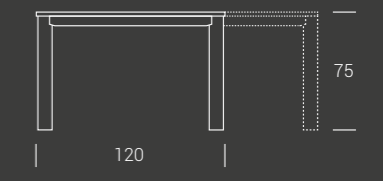
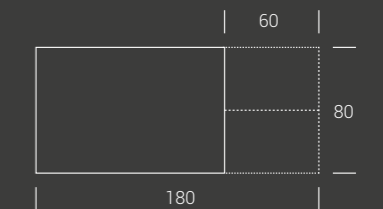

STORM

STORM È IL TAVOLO ALLUNGABILE CHE PIÙ DI TUTTI ESPRIME QUOTIDIANITÀ E SOBRIETÀ: UN TAVOLO CONSIGLIATO PER CHI HA VOGLIA DI VIVERE LA CASA IN MODO PRATICO E INFORMALE, SENZA PREOCCUPARSI TROPPO, PER CHI INSOMMA PREDILIGE UN MOOD EASY E CASUAL.

Storm est la version plus sobre et simple parmi les tables extensibles: une table recommandée pour ceux qui veulent vivre la maison en toute praticité et informalité, sans soucis.

Storm is an extending kitchen table that mostly expresses daily life and sobriety. This table is recommended for those who want to live the house in a handy and informal way, without worrying too much. It has an easy and casual style.



S T O R M



372

STORM
design Altacom



373

S T O R M



FINITURE PIANO FINITIONS PLATEAU TOP FINISHES

NOBILITATO / MÉLAMINE / MELAMINE

N20	Natural halifax oak
N23	Cemento
N24	Ardesia
N25	Vintage chiaro
N30	Morera
N33	Resina silver
N34	Resina grigio cenere
N35	Rovere nodato caramel
N36	Olmo moka
N40	Noce Canaletto
N42	Rovere nero
N43	Bianco spatolato
N44	Bianco statuario venato
N45	Diamond cream
N46	Pietra grey

VETRO / VERRE / GLASS

G01	Bianco lucido
G02	Tortora lucido
G03	Nero lucido
G04	Bianco acidato
G05	Tortora acidato
G06	Nero acidato

**Tavolo da pranzo, struttura
allungabile in metallo,
meccanismo telescopico,
piano in nobilitato o vetro,
prolunga interna a libro.**

Table de repas avec rallonge
portefeuille intégrée, structure en
métal, plateau mélamine ou verre,
mécanisme télescopique.

Metal frame dining table with
telescopic extending mechanism, top
in melamine or glass, inside folded
extension.

FINITURE BASE FINITIONS PIÉTEMENT BASE FINISHES

METALLO / MÉTAUX / METALS

M02	Verniciato grisou goffrato
M04	Verniciato nero opaco
M05	Cromo lucido
M11	Verniciato grafite goffrato
M12	Verniciato tortora opaco
M19	Verniciato bronzo goffrato
M24	Verniciato bianco goffrato

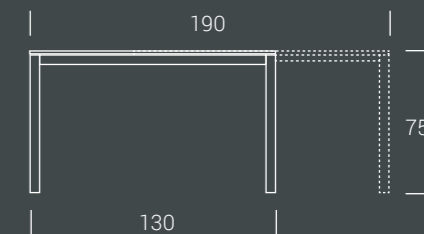
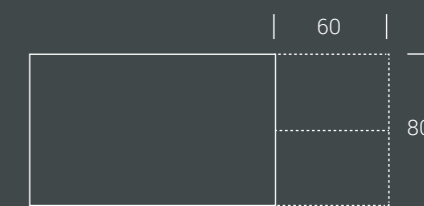
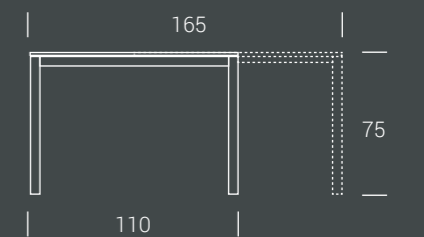
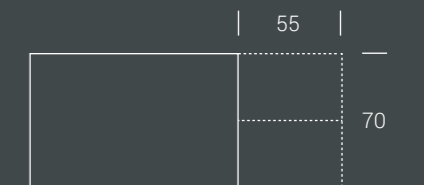

COMPASSO

IL DETTAGLIO CHE DISTINGUE IL TAVOLO COMPASSO È LA SEZIONE TRIANGOLARE DELLA GAMBA CON GLI SPIGOLI ARROTONDATI. IL PIANO IN NOBILITATO PUÒ RADDOPPIARE LA SUA LUNGHEZZA, SENZA APPESANTIRE L'IMMAGINE ESILE E LEGGERA DEL TAVOLO.

Le détail le plus intéressant de la table Compasso est la section triangulaire du pied, avec ses coins arrondis. Le plateau en mélamine peut doubler sa longueur, sans alourdir le design léger et élégant de cette table.

The detail that distinguishes table Compasso is the triangular section of the leg with smooth edges. The melamine top can double its length without adding weight on the thin and light image of the table.



Base/Piédement/Base: verniciato grafite gofrato M11
Piano/Plateau/Top: nobilitato pietra grey N46



COMPASSO



COMPASSO



COMPASSO



FINITURE PIANO FINITIONS PLATEAU TOP FINISHES

NOBILITATO / MÉLAMINE / MELAMINE

N20	Natural halifax oak
N23	Cemento
N24	Ardesia
N25	Vintage chiaro
N30	Morera
N33	Resina silver
N34	Resina grigio cenere
N35	Rovere nodato caramelo
N36	Olmo moka
N40	Noce Canaletto
N42	Rovere nero
N43	Bianco spatolato
N44	Bianco statuario venato
N45	Diamond cream
N46	Pietra grey

LACCATO / LAQUÉ / LACQUERED

Poro aperto / Pores ouverts / Open pore

L31	Bianco luce
L32	Bianco panna
L33	Bianco vela
L34	Grigio corda
L35	Grigio canapa
L39	Rosso aragosta
L40	Tortora

LEGNO IMPIALLACCIATO / PLACAGE BOIS / VENEER WOOD

W02	Rovere grigio
W03	Rovere tabacco
W04	Rovere nodato
W06	Rovere juta
W07	Rovere fumé
W10	Noce Canaletto

VETRO / VERRE / GLASS

G01	Bianco lucido
G02	Tortora lucido
G03	Nero lucido
G04	Bianco acidato
G05	Tortora acidato
G06	Nero acidato

EFFETTO MALTA / EFFET-BÉTON / MORTAR-LOOK

E04	Metalli vissuti nichel
E06	Beton tortora
E07	Beton nero
E08	Beton grigio scuro
E09	Beton grigio chiaro
E15	Pietra spatolata travertino metallizzato bianco
E19	Bianco assoluto
E20	Gros carruba
E21	Gros ciocco
E22	Ruggine
E23	Rock silver
E24	Rock copper
E25	Rock cemento

CERAMICA / CÉRAMIQUE / CERAMIC

K01	Fokos Sale
K02	Fokos Terra
K03	Fokos Piombo
K04	Noir Desir lucido
K05	Bianco Statuario venato lucido
K06	Diamond Cream lucido
K07	Pietra Grey lucida
K09	Oxide Nero
K10	Oxide Bianco
K11	Pietra Savoia Antracite
K12	Pietra di Savoia Perla
K13	Calacatta Gold lucido
K14	Emperador lucido
K15	Noir Desir opaco
K16	Pietra Grey opaco
K17	Calacatta Gold opaco
K18	Bianco Statuario venato opaco
K19	Diamond Cream opaco
K20	Emperador opaco

Tavolo da pranzo, struttura allungabile in metallo, meccanismo telescopico, piano in nobilitato, legno, effetto malta, vetro o ceramica. Disponibile con meccanismo tradizionale e allunghe a libro o con meccanismo super allungabile con allunghe interne.

Table de repas, structure en métal, plateau mélamine, verre, bois, laqué, effet-béton ou céramique, mécanisme télescopique. Disponible avec mécanique traditionnel et rallonges porte-feuille, ou mécanique super-extensible avec rallonges intégrées.

Metal frame dining table with telescopic extending mechanism, top in melamine, glass, stained wood, mortar-look or ceramic. Available with traditional mechanism and book extensions or with super-extendable mechanism and inside extensions.

FINITURE BASE FINITIONS PIÉTEMENT BASE FINISHES

METALLO / MÉTAUX / METALS

M02	Vern. grisou goffrato
M04	Vern. nero opaco
M11	Vern. grafite goffrato
M12	Vern. tortora opaco
M19	Vern. bronzo goffrato
M24	Vern. bianco goffrato

COMPASSO SUPER

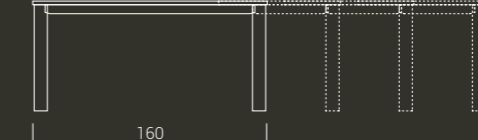
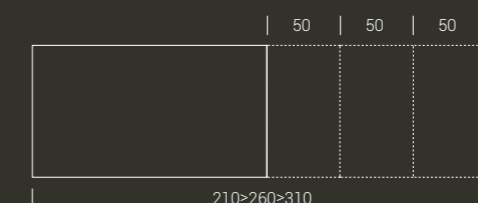
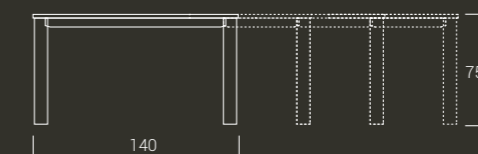
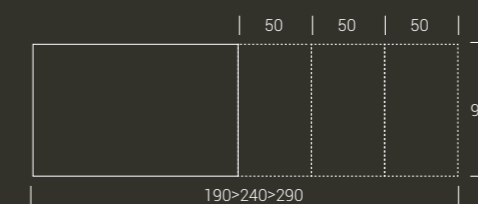
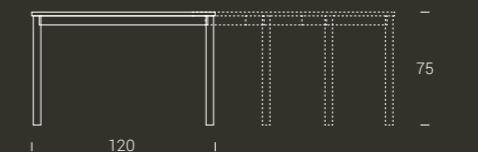
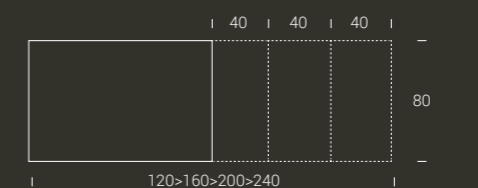

COMPASSO

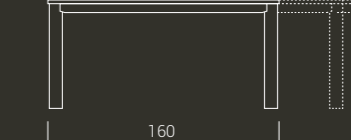
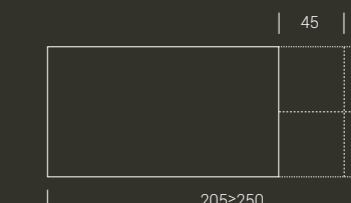
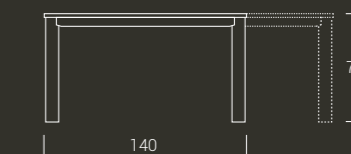
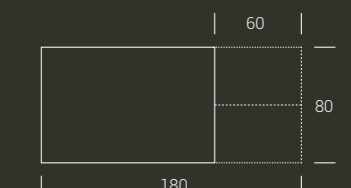

TOWER MAXI

UN TAVOLO ALLUNGABILE CHE SA REGALARE GRANDI, ANZI ENORMI EMOZIONI. NELLA VERSIONE DA SOGGIORNO È PICCOLO E DISCRETO, MA QUANDO SI APRE DIVENTA UN TAVOLO DA PRANZO DI QUASI 5 METRI DI LUNGHEZZA, PER OSPITARE VERAMENTE TUTTI GLI INVITATI CHE VUOI. DA TOWER MAXI PUOI SOLO LASCIARTI PIACEVOLMENTE SORPRENDERE.

Une table extensible qui donne de grandes émotions. En position fermée elle est petite et discrète, mais son extension jusqu'à presque 5 mètres permet d'accueillir à table tout le monde: Tower Maxi est une table facilement étonnante, n'est-ce pas?

Tower Maxi is a table that gives real emotions. In the living room version is small and discrete but when open it gets to 5 metres length, to host all the friends you want. It's a massive solution.





TOWER MAXI



TOWER MAXI



**Tavolo da pranzo allungabile,
base centrale in metallo,
piano in nobilitato, legno
o effetto-malta, 6 prolunghe
interne, gambe pieghevoli
di supporto.**

en métal, plateau melamine, bois, ou
effet-béton, 6 rallonges intégrées,
pieds pliables à support des rallonges.

base, top in melamine, wood or
mortar-look, 6 inside extensions,
supporting folding legs.

Table de repas avec piétement central

Extending dining table with metal

FINITURE PIANO FINITIONS PLATEAU TOP FINISHES

NOBILITATO / MÉLAMINE / MELAMINE

N20	Natural halifax oak
N23	Cemento
N24	Ardesia
N25	Vintage chiaro
N30	Morera
N33	Resina silver
N34	Resina grigio cenere
N35	Rovere nodato caramel
N36	Olmo moka
N40	Noce Canaletto
N42	Rovere nero
N43	Bianco spatolato
N44	Bianco statuario venato
N45	Diamond cream
N46	Pietra grey

LACCATO / LAQUÉ / LACQUERED

Poro aperto / Pores ouverts / Open pore

L31	Bianco luce
L32	Bianco panna
L33	Bianco vela
L34	Grigio corda
L35	Grigio canapa
L39	Rosso aragosta
L40	Tortora

LEGNO IMPIALLACCIATO / PLACAGE BOIS / VENEER WOOD

W02	Rovere grigio
W03	Rovere tabacco
W04	Rovere nodato
W06	Rovere juta
W07	Rovere fumé

EFFETTO MALTA / EFFET-BÉTON / MORTAR-LOOK

E04	Metalli vissuti nichel
E06	Beton tortora
E07	Beton nero
E08	Beton grigio scuro
E09	Beton grigio chiaro
E15	Pietra spatolata travertino metallizzato bianco
E19	Bianco assoluto
E20	Gros carruba
E21	Gros ciocco
E22	Ruggine
E23	Rock silver
E24	Rock copper
E25	Rock cemento

FINITURE BASE FINITIONS PIÉTEMENT BASE FINISHES

METALLO / MÉTAUX / METALS

M01	Inox
M02	Verniciato grisou goffrato
M04	Verniciato nero opaco
M11	Verniciato grafite goffrato
M12	Verniciato tortora opaco
M19	Verniciato bronzo goffrato
M24	Verniciato bianco goffrato

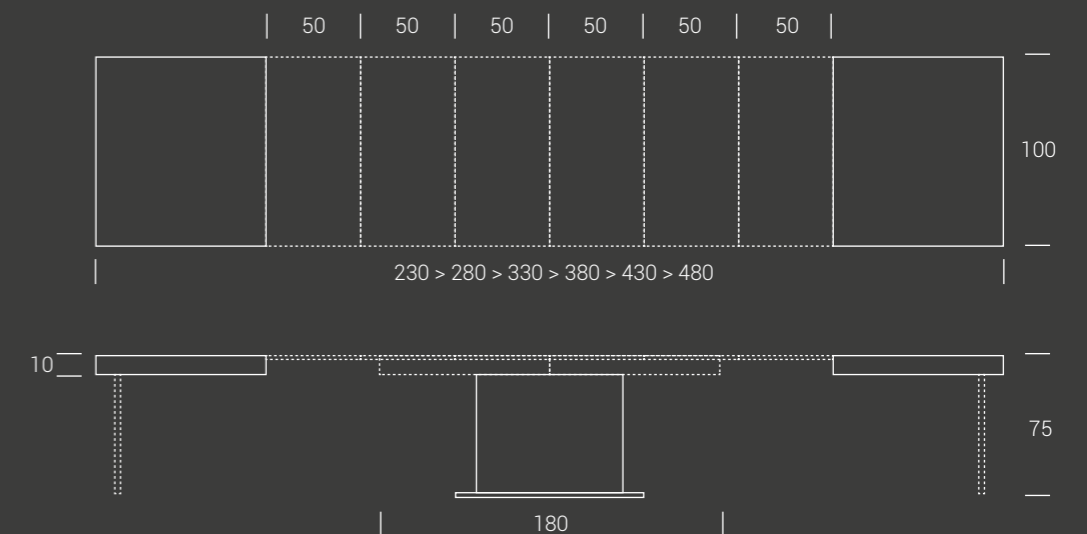

SEIDIE

JOLIE

pg 394

JOLIE WOOD

pg 395

NANETTE

pg 396

MARIANNA

pg 397

DANDY

pg 398

MOLLY

pg 399

ERIKA

pg 400

HIPPO

pg 401

LE SEDIE DELLA COLLEZIONE ALTACOM SONO ACCOSTABILI AI DIFFERENTI CONTESTI D'ARREDO IN VIRTÙ DI UN DESIGN SOBRIO E RAFFINATO. LE LORO SEDUTE SONO ERGONOMICHE PERCIÒ CONFORTEVOLI, I LORO RIVESTIMENTI SONO COSTITUITI DALLA SCELTA DI CINQUE CROMIE DI TENDENZA REALIZZATE IN PELLE, ECOPELLE ED ECOPELLE NABUK.

Les chaises de la collection Altacom peuvent être combinées avec de différents environnements, grâce à leur design discret et élégant. Leurs assises sont ergonomiques et confortables, leurs revêtements sont disponibles en cinq couleurs de tendance, réalisées en cuir, éco-cuir et éco-cuir nabuk.

The chairs of Altacom collection can be matched to different furnished backgrounds thanks to their sober and elegant design. Their seating is ergonomic, which confers them comfort. The leather, ecoleather and nabuk ecoleather covering is available in five different trending colors.

Per le caratteristiche della sedia di pagina 278 e dello sgabello di pagina 346 vedere catalogo Compar.

Pour les détails de la chaise à la page 278 et du tabouret à la page 346, merci de regarder le catalogue Compar.

For the characteristics of the chair at page 278 and the stool at page 346, please check the Compar catalogue.

JOLIE



Metallo verniciato M19 e Rovere tabacco W03 / Metallo verniciato M11 e Rovere grigio W02

LEGNO IMPIALLACCIATO
/ PLACAGE BOIS
/ VENEER WOOD

- W02 Rovere grigio
- W03 Rovere tabacco
- W04 Rovere nodato

LACCATO PORO APERTO
/ LAQUÉ PORES OUVERTS
/ OPEN PORE LACQUER

- L33 Bianco vela
- L40 Tortora

METALLO
/ MÉTAUX
/ METALS

- M02 Vern. grisou gofrato
- M04 Vern. nero opaco
- M11 Vern. grafite gofrato
- M12 Vern. tortora opaco
- M19 Vern. bronzo gofrato
- M24 Vern. bianco gofrato

GANCIO SEDIE
OPTIONAL

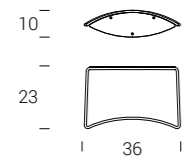

CARRELLO SEDIE
OPTIONAL

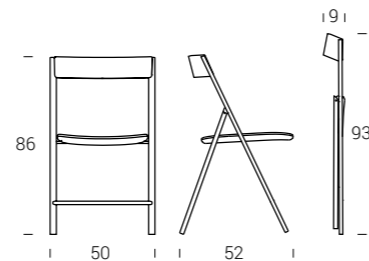
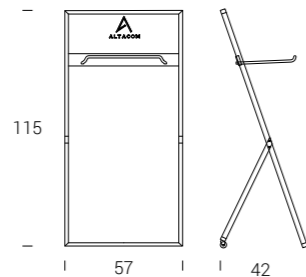

Sedia con struttura e schienale in metallo. Seduta in legno.

Chaise avec structure et dossier en métal, assise en chêne.

Chair with a metal frame and back, wood seating.

JOLIE WOOD



Metallo verniciato M19 e Rovere nodato W04

LEGNO IMPIALLACCIATO
/ PLACAGE BOIS
/ VENEER WOOD

- W02 Rovere grigio
- W03 Rovere tabacco
- W04 Rovere nodato

LACCATO PORO APERTO
/ LAQUÉ PORES OUVERTS
/ OPEN PORE LACQUER

- L33 Bianco vela
- L40 Tortora

METALLO
/ MÉTAUX
/ METALS

- M02 Vern. grisou gofrato
- M04 Vern. nero opaco
- M11 Vern. grafite gofrato
- M12 Vern. tortora opaco
- M19 Vern. bronzo gofrato
- M24 Vern. bianco gofrato

GANCIO SEDIE
OPTIONAL

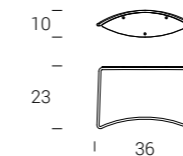

CARRELLO SEDIE
OPTIONAL

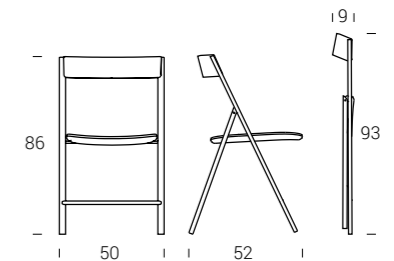
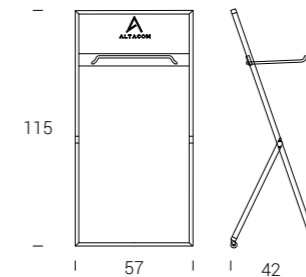

Sedia con struttura in metallo. Schienale e seduta in legno.

Chaise avec structure en métal, assise et dossier en chêne.

Chair with a metal frame, wood seating and back.

NANETTE



Ecopelle nabuk grigio NB17

ECOPELLE NABUK / ECO-CUIR NABUK / ECO-LEATHER NABUK

- NB07 Ecopelle nabuk grigio
- NB08 Ecopelle nabuk bianco
- NB17 Ecopelle nabuk tortora

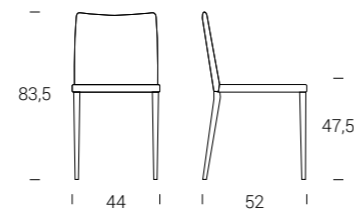

ECOPELLE / ECO-CUIR / ECO-LEATHER

- EC01 Ecopelle bianco
- EC37 Ecopelle sabbia
- EC62 Ecopelle grafite
- EC91 Ecopelle nero

Sedia con struttura in metallo rivestita in ecopelle ed ecopelle nabuk.

Chaise avec structure en métal, revêtement en eco-cuir et eco-cuir nabuk.

Metal frame chair with soft eco-leather and soft eco-leather nabuk covering.

NANETTE
design Altacom

MARIANNA



Pelle bianco ottico P15

PELLE / CUIR / LEATHER

- P11 Pelle nero
- P15 Pelle bianco ottico
- P16 Pelle sabbia
- P17 Pelle grafite

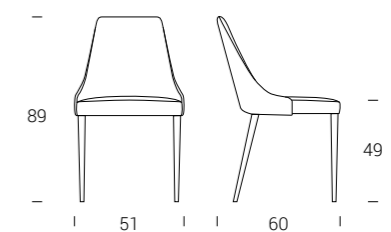

ECOPELLE NABUK / ECO-CUIR NABUK / ECO-LEATHER NABUK

- NB07 Ecopelle nabuk grigio
- NB08 Ecopelle nabuk bianco
- NB17 Ecopelle nabuk tortora

Sedia con struttura in metallo rivestita in pelle ed ecopelle nabuk.

Chaise avec structure en métal, revêtement en cuir et eco-cuir nabuk.

Metal frame chair with soft leather and soft eco-leather nabuk covering.

MARIANNA
design Altacom

DANDY



Pelle grafite P17

ECOPELLE NABUK / ECO-CUIR NABUK / ECO-LEATHER NABUK

- NB07 Ecopelle nabuk grigio
- NB08 Ecopelle nabuk bianco
- NB17 Ecopelle nabuk tortora

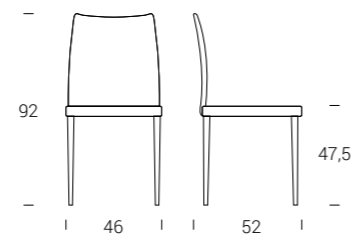

ECOPELLE / ECO-CUIR / ECO-LEATHER

- EC01 Ecopelle bianco
- EC37 Ecopelle sabbia
- EC62 Ecopelle grafite
- EC91 Ecopelle nero

**Sedia con struttura in metallo
rivestita in ecopelle ed
ecopelle nabuk.**

**Chaise avec structure en métal,
revêtement en eco-cuir et eco-cuir
nabuk.**

**Metal frame chair with soft eco-leather
and soft eco-leather nabuk covering.**

DANDY
design Altacom

MOLLY



Pelle sabbia P16

PELLE / CUIR / LEATHER

- P11 Pelle nero
- P15 Pelle bianco ottico
- P16 Pelle sabbia
- P17 Pelle grafite

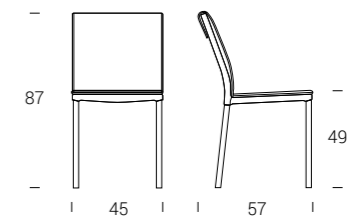

**Sedia con struttura in metallo
rivestita in pelle.**

**Chaise avec structure en métal,
revêtement en cuir.**

**Metal frame chair with soft leather
covering.**

MOLLY
design Altacom

ERIKA



Cuoietto moka C08

CUOIETTO / CROÛTE DE CUIR / SPLIT LEATHER

- C01 Bianco
- C02 Avorio
- C03 Sand
- C05 Grigio chiaro
- C08 Moka
- C09 Grigio titanio
- C10 Nero
- C11 Tortora

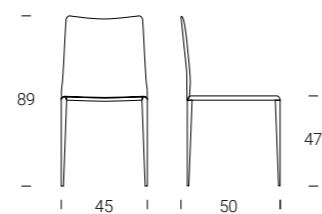

Sedia con struttura in metallo rivestita in cuoietto.

Chaise avec structure en métal, revêtement en croûte de cuir sellier.

Metal frame chair with split leather covering.

HIPPO



Cuoietto bianco C01

CUOIETTO / CROÛTE DE CUIR / SPLIT LEATHER

- C01 Bianco
- C02 Avorio
- C03 Sand
- C05 Grigio chiaro
- C08 Moka
- C09 Grigio titanio
- C10 Nero
- C11 Tortora

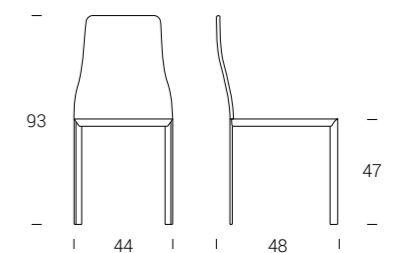

Sedia con struttura in metallo rivestita in cuoietto.

Chaise avec structure en métal, revêtement en croûte de cuir sellier.

Metal frame chair with thick split leather covering.

TAVOLINI & SGABELLI

CENTER / PROFILO

pg 404

OUTLINE / DROP

pg 408

ITACA

pg 414

LA LINEA DI TAVOLINI E SGABELLI "CONTRACT" DI ALTACOM SI RIVELANO LA SOLUZIONE IDEALE PER ARREDARE AMBIENTI PROFESSIONALI CONFERENDO STILE E VERSATILITÀ DI UTILIZZO. TAVOLINI E SGABELLI FACILMENTE REGOLABILI IN ALTEZZA INVENTANO NUOVI MODI PER UNA CONVIVIALITÀ CHE PONE L'ACCENTO SULLA MODERNITÀ.

La famille « Contract » des tables réglables et des tabourets est la solution idéale pour meubler l'environnement professionnel, en donnant du style et de la versatilité. Des tables et des tabourets facilement réglables en hauteur, qui inventent de nouveaux moyens pour vivre la convivialité avec plus de modernité.

Altacom contract series of height adjustable tables and stools is the ideal solution to furnish professional locations with style and versatility of use. Table and stools easily adjustable in height create new ways to live conviviality with a touch of modernity.

CENTER / PROFILO

IL TAVOLINO CENTER, REGOLABILE IN ALTEZZA MEDIANTE MECCANISMO A GAS PUÒ ESSERE ABBINATO ALLO SGABELLO DROP O PROFILO SECONDO I VOSTRI GUSTI E ABBINAMENTI FINITURE. LA SEDUTA, COMODA E VERSATILE, CONFERISCE AL "CONTRACT" CONTEMPORANEO MASSIMO COMFORT E PRATICITÀ.

La table Center, réglable en hauteur par vérin-gaz, peut être assortie au tabouret Drop ou Profilo, selon vos goûts et vos préférences. L'assise, confortable et versatile, donne du confort et du design, pour un Contract contemporain.

The table "Center", height-adjustable through a gas lifting mechanism, can be matched to the stool "Drop" or "Profilo" according to your taste. The comfortable and versatile seating gives the contemporary "Contract" collection maximum comfort and convenience.



CENTER Base/Piètement/Base: cromo lucido M05
Piano/Plateau/Top: rovere nodato W04

PROFILO Base/Piètement/Base: cromo lucido M05
Scocca/Coque/Shell: rovere nodato W04

/ CENTER



Tavolo regolabile in altezza con meccanismo a gas, piano in vetro, legno o effetto malta, struttura in metallo, disponibile in due versioni di

altezza.

Table réglable en hauteur par vérin-gaz avec plateau verre, bois, ou effet-béton, piétement en métal, disponible en deux hauteurs.

Height adjustable table with glass, wood or mortar-look top, metal base, gas lifting, available in two heights.

/ PROFILO



Sgabello girevole in metallo, meccanismo a gas regolabile in altezza da cm 52 a cm 71, scocca in cuoietto o rovere.

Tabouret tournant en métal,haussement par vérin-gaz de cm 52 à cm 71, coque en croûte de cuir sellier ou chêne.

Metal frame swivel stool, gas adjustable height from cm 52 to cm 71, shell in thick split leather or oak.

FINITURE PIANO FINITIONS PLATEAU TOP FINISHES

VETRO / VERRE / GLASS

- G01 Bianco lucido
- G02 Tortora lucido
- G03 Nero lucido

LEGNO IMPIALLACCIATO / PLACAGE BOIS / VENEER WOOD

- W02 Rovere grigio
- W03 Rovere tabacco
- W04 Rovere nodato
- W06 Rovere juta
- W07 Rovere fumé

LACCATO / LAQUÉ / LACQUERED

Poro aperto
/ Pores ouverts
/ Open pore

- L31 Bianco luce
- L32 Bianco panna
- L33 Bianco vela
- L34 Grigio corda
- L35 Grigio canapa
- L39 Rosso aragosta
- L40 Tortora

EFFETTO MALTA / EFFET-BÉTON / MORTAR-LOOK

- E04 Metalli vissuti nichel
- E06 Beton tortora
- E07 Beton nero
- E08 Beton grigio scuro
- E09 Beton grigio chiaro
- E15 Pietra spatolata travertino metallizzato bianco
- E19 Bianco assoluto
- E20 Gros carruba
- E21 Gros ciocco
- E22 Ruggine
- E23 Rock silver
- E24 Rock copper
- E25 Rock cemento

FINITURE FINITIONS FINISHES

CUOIETTO / CROÛTE DE CUIR / SPLIT LEATHER

- C01 Bianco
- C02 Avorio
- C03 Sand
- C05 Grigio chiaro
- C08 Moka
- C09 Grigio titanio
- C10 Nero
- C11 Tortora

LEGNO IMPIALLACCIATO / PLACAGE BOIS / VENEER WOOD

- W02 Rovere grigio
- W03 Rovere tabacco
- W04 Rovere nodato
- W06 Rovere juta
- W07 Rovere fumé

FINITURE BASE FINITIONS PIÉTEMENT BASE FINISHES

METALLO / MÉTAUX / METALS

- M02 Verniciato grisou goffrato
- M04 Verniciato nero opaco
- M05 Cromo lucido
- M11 Verniciato grafite goffrato
- M12 Verniciato tortora opaco
- M19 Verniciato bronzo goffrato
- M24 Verniciato bianco goffrato

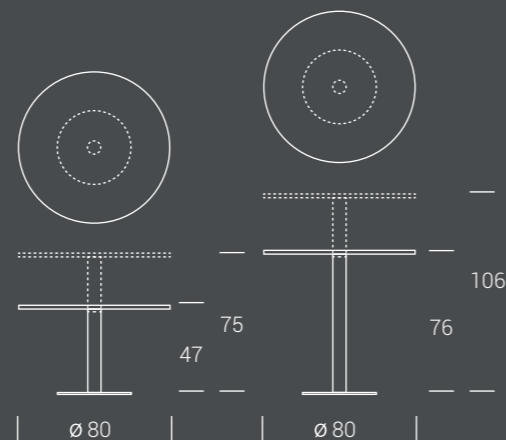

FINITURE BASE FINITIONS PIÉTEMENT BASE FINISHES

METALLO / MÉTAUX / METALS

- M02 Verniciato grisou goffrato
- M04 Verniciato nero opaco
- M05 Cromo lucido
- M11 Verniciato grafite goffrato
- M12 Verniciato tortora opaco
- M19 Verniciato bronzo goffrato
- M24 Verniciato bianco goffrato

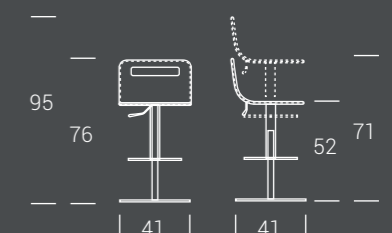

OUTLINE / DROP

BENVENUTI NELLO SPAZIO PUBBLICO ARREDATO CON OUTLINE CHE SI PRESENTA IN FORMA "ERGONOMICA" CAPACE DI ASSECONDARE LE DIVERSE ESIGENZE DEL CONTRACT CONTEMPORANEO. GRAZIE ALLA FLESSIBILITÀ DELLE SUE POSIZIONI REGOLA L'ALTEZZA ATTRAVERSO IL MECCANISMO A GAS. LO SGABELLO DROP ANCH'ESSO REGOLABILE IN ALTEZZA INDUCE AD ACCOMODARSI PIACEVOLMENTE NELLA SEDUTA "MONOSCOCCA" PER GODERSI UNO SNACK O SORSEGGIARE UN DRINK IN PIACEVOLE COMPAGNIA.

Bienvenue dans l'espace public aménagé avec Outline, qui se présente avec sa forme ergonomique, capable de répondre aux différentes exigences du Contract contemporain. Grâce à la flexibilité de ses positions, elle règle son hauteur par son mécanisme vérin-gaz. Le tabouret Drop, également réglable en hauteur, invite à s'accommoder agréablement dans son assise, pour goûter un snack ou siroter un drink en bonne compagnie.

Welcome to the public space furnished with Outline, whose "ergonomic" shape can indulge the different needs of the contemporary contract. Thanks to its flexibility, the height can be adjusted through a gas mechanism. The Drop stool, adjustable in height as well, persuades people to make themselves at home on the unique seat, where they can enjoy a snack or a drink in company.



OUTLINE Base/Piédement/Base: verniciato grafite goffrato M11
Piano/Plateau/Top: effetto beton nero E07

DROP Base/Piédement/Base: verniciato grafite goffrato M11
Scocca/Coque/Shell: rovere nodato W04

OUTLINE / DROP
design Altacom





OUTLINE



Tavolo regolabile in altezza con meccanismo a gas, piano in legno o effetto malta, struttura in metallo, disponibile in due versioni di altezza.
Table réglable en

hauteur par vérin-gaz avec plateau bois, ou effet-béton, piétement en métal, disponible en deux hauteurs.

Height adjustable table

with wood or mortar-look top, metal base, gas lifting, available in two heights.

DROP



Sgabello girevole in metallo, meccanismo a gas regolabile in altezza da cm 52 a cm 71, scocca in cuoietto o rovere.

métal, haussement par vérin-gaz de cm 52 à cm 71, coque en croûte de cuir ou chêne.

gas adjustable height from cm 52 to cm 71, split leather or oak shell.

Tabouret tournant en

Metal frame swivel stool,

FINITURE PIANO FINITIONS PLATEAU TOP FINISHES

LEGNO IMPIALLACCIATO / PLACAGE BOIS / VENEER WOOD

W02	Rovere grigio
W03	Rovere tabacco
W04	Rovere nodato
W06	Rovere juta
W07	Rovere fumé

LACCATO / LAQUÉ / LACQUERED

Poro aperto
/ Pores ouverts
/ Open pore

L31	Bianco luce
L32	Bianco panna
L33	Bianco vela
L34	Grigio corda
L35	Grigio canapa
L39	Rosso aragosta
L40	Tortora

EFFETTO MALTA / EFFET-BÉTON / MORTAR-LOOK

E04	Metalli vissuti nichel
E06	Beton tortora
E07	Beton nero
E08	Beton grigio scuro
E09	Beton grigio chiaro
E15	Pietra spatolata travertino metallizzato bianco
E19	Bianco assoluto
E20	Gros carruba
E21	Gros ciocco
E22	Ruggine
E23	Rock silver
E24	Rock copper
E25	Rock cemento

FINITURE FINITIONS FINISHES

CUOIETTO / CROÛTE DE CUIR / SPLIT LEATHER

C01	Bianco
C02	Avorio
C03	Sand
C05	Grigio chiaro
C08	Moka
C09	Grigio titanio
C10	Nero
C11	Tortora

LEGNO IMPIALLACCIATO / PLACAGE BOIS / VENEER WOOD

W02	Rovere grigio
W03	Rovere tabacco
W04	Rovere nodato
W06	Rovere juta
W07	Rovere fumé

FINITURE BASE FINITIONS PIÉTEMENT BASE FINISHES

METALLO / MÉTAUX / METALS

M02	Verniciato grisou goffrato
M04	Verniciato nero opaco
M05	Cromo lucido
M11	Verniciato grafite goffrato
M12	Verniciato tortora opaco
M19	Verniciato bronzo goffrato
M24	Verniciato bianco goffrato

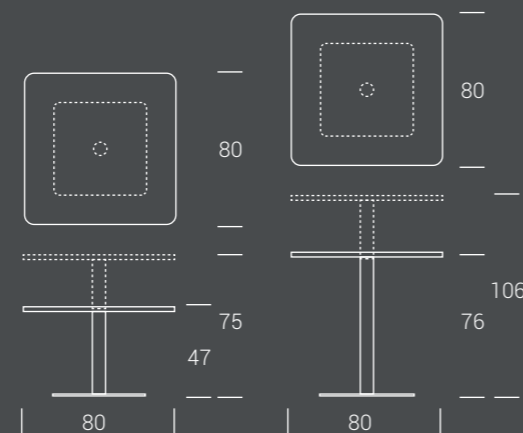

FINITURE BASE FINITIONS PIÉTEMENT BASE FINISHES

METALLO / MÉTAUX / METALS

M02	Verniciato grisou goffrato
M04	Verniciato nero opaco
M05	Cromo lucido
M11	Verniciato grafite goffrato
M12	Verniciato tortora opaco
M19	Verniciato bronzo goffrato
M24	Verniciato bianco goffrato

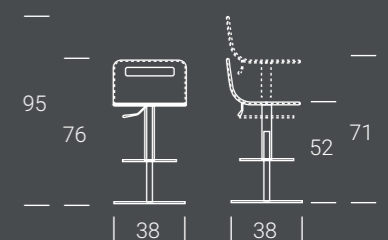

ITACA



ITACA



**Sgabello in metallo,
meccanismo a gas
regolabile in altezza da cm
52 a cm 79, scocca rivestita
in cuoietto.**

Tabouret tournant en métal,
haussement par vérin-gaz de cm
52 à cm 79, revêtement coque en
croûte de cuir sellier.

Metal frame stool, gas adjustable
height from cm 52 to cm 79,
split leather covering.

FINITURE
FINITIONS
FINISHES

CUOIETTO
/ CROÛTE DE CUIR
/ SPLIT LEATHER

C01	Bianco
C02	Avorio
C03	Sand
C05	Grigio chiaro
C08	Moka
C09	Grigio titanio
C10	Nero
C11	Tortora

METALLO
/ MÉTAUX
/ METALS

M05	Cromo lucido
-----	--------------

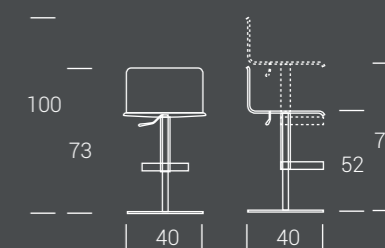

MATERIALI MATÉRIAUX MATERIALS

AVRETE A DISPOSIZIONE UNA VASTA GAMMA DI MATERIALI PER POTER SCEGLIERE LA SOLUZIONE PIÙ CONGENIALE AL VOSTRO ARREDO. DAI PIANI ALLA STRUTTURA DI TAVOLI E TAVOLINI ALLA SEDUTA DI SEDIE E SGABELLI NELLE DIVERSE FINITURE E CROMIE NELLE NUANCE PIÙ ATTUALI.

Vous aurez à disposition une large gamme de matériaux pour pouvoir choisir la solution qui mieux se décline à votre ambiance. Des plateaux jusqu'à la structure des tables, des tables relevables, aux assises des chaises et des tabourets dans les différentes finitions aux nuances les plus actuelles.

A large selection of materials is available to choose the best solution for your furniture. From the tops of the tables to the seating of chairs and stools with different finishes and colors in the most current nuances.

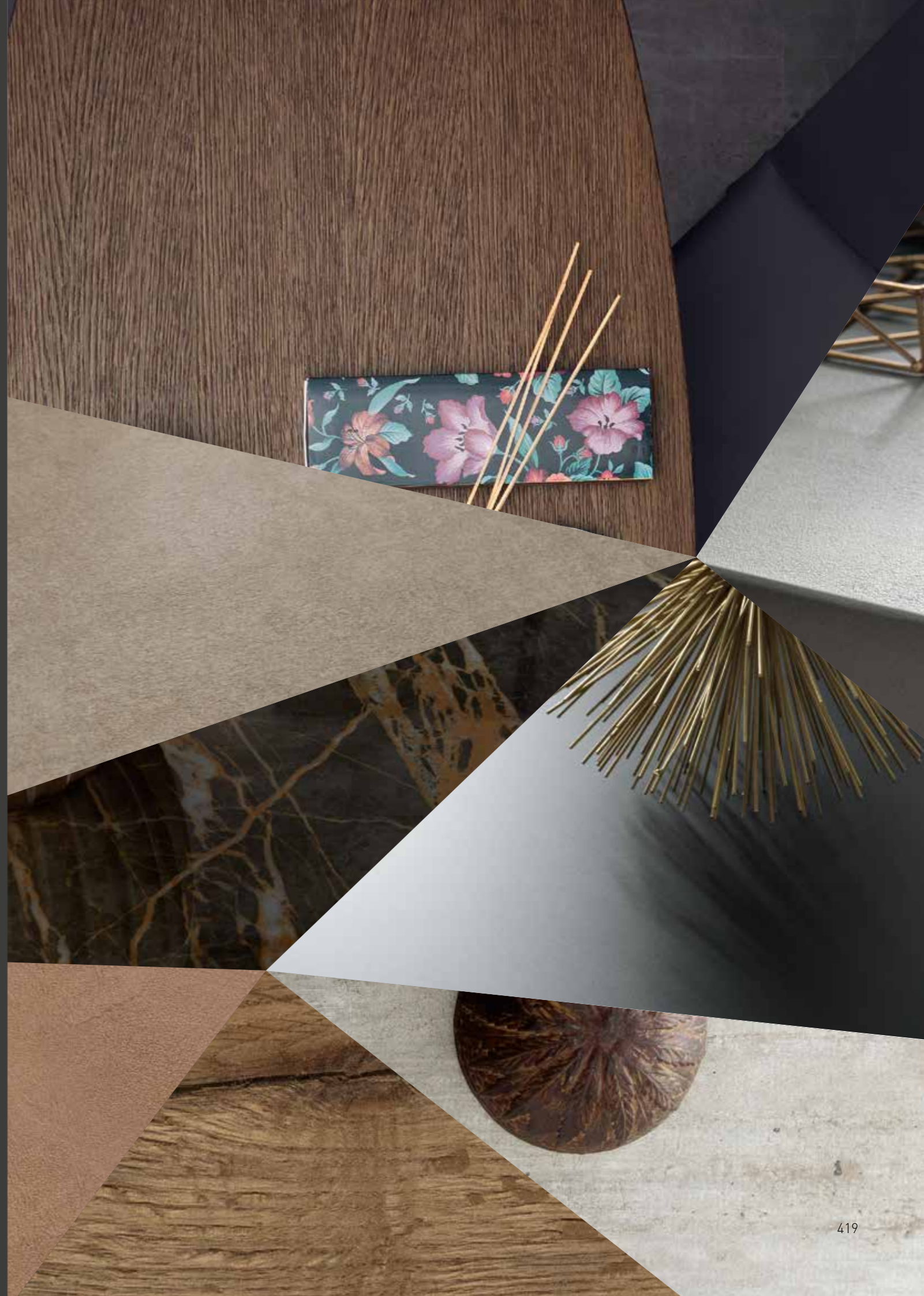

FINITURE / FINITIONS / FINISHES

METALLO / MÉTAUX / METALS

- M01 Inox
- M02 Vernic. grisou goffrato
- M04 Vernic. nero opaco
- M05 Cromo lucido
- M09 Cromo nero lucido
- M11 Vernic. grafite goffrato
- M12 Vernic. tortora opaco
- M19 Vernic. bronzo goffrato
- M24 Vernic. bianco goffrato

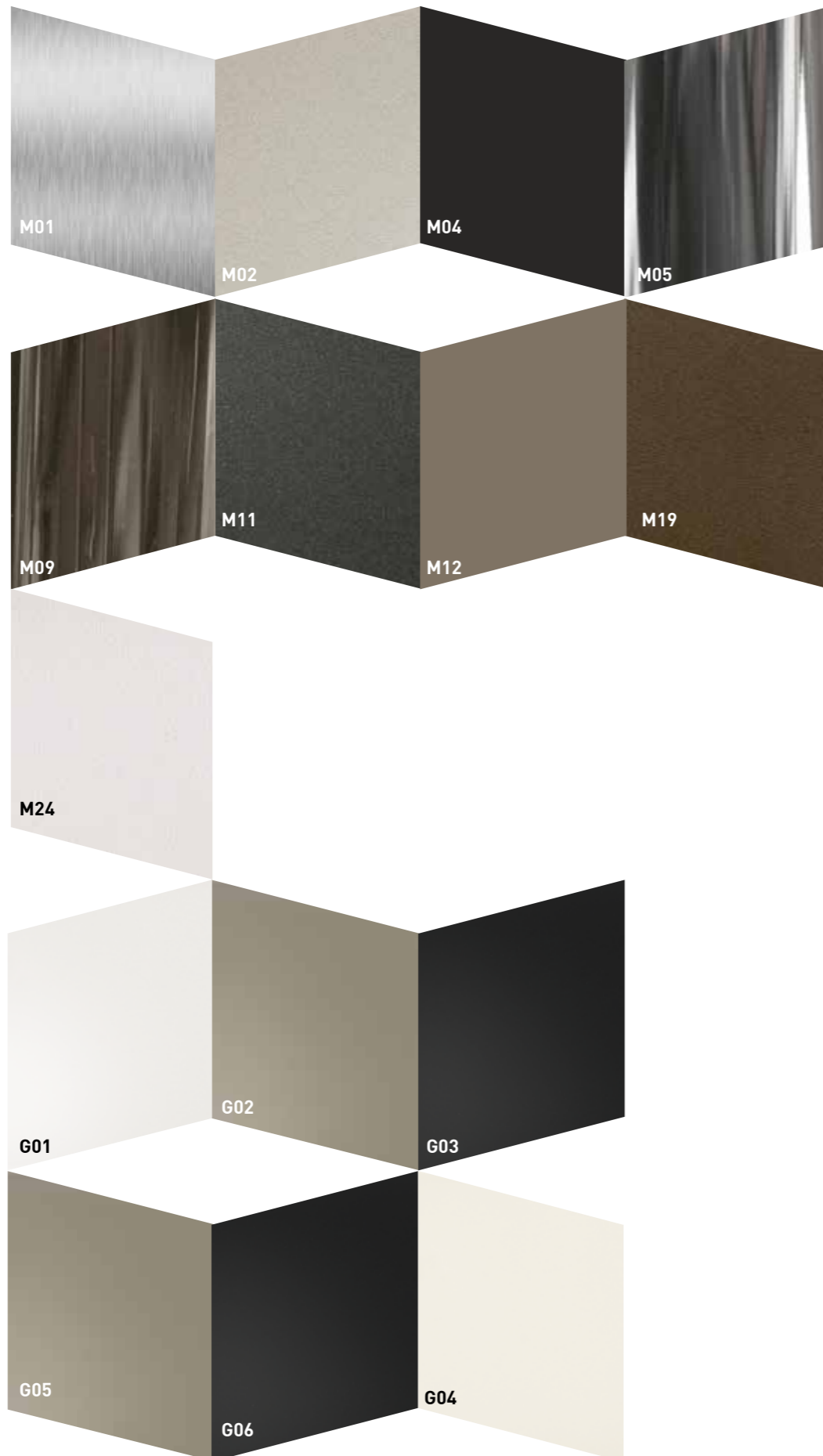

VETRO / VERRE / GLASS

- G01 Bianco lucido
- G02 Tortora lucido
- G03 Nero lucido
- G04 Bianco acidato
- G05 Tortora acidato
- G06 Nero acidato

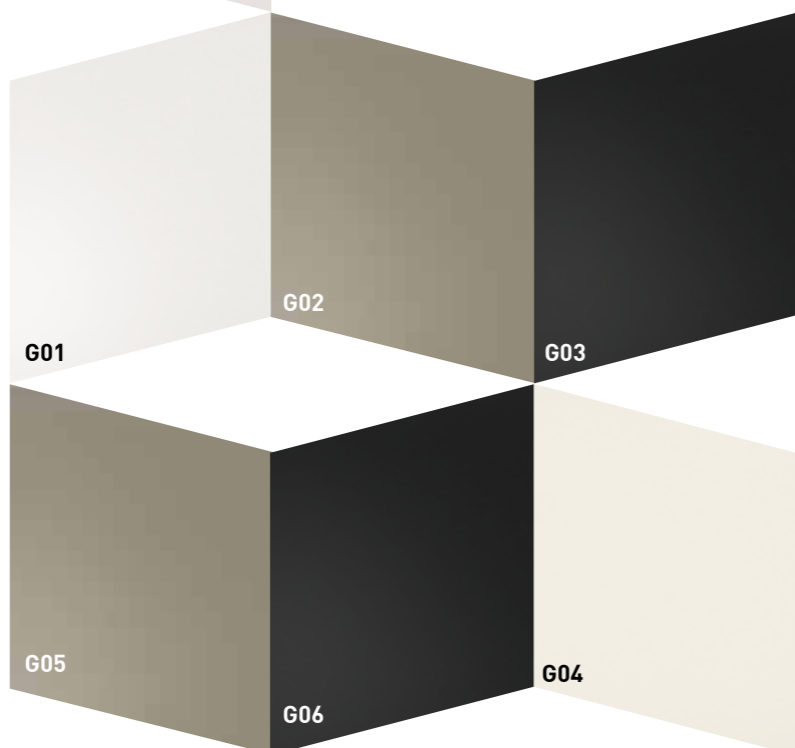

FINITURE / FINITIONS / FINISHES

EFFETTO MALTA / EFFET BÉTON / MORTAR LOOK

- E04 Metalli vissuti nichel
- E06 Beton tortora
- E07 Beton nero
- E08 Beton grigio scuro
- E09 Beton grigio chiaro
- E15 Pietra spatolata travertino metallizzato bianco
- E19 Bianco assoluto
- E20 Gros carruba
- E21 Gros ciocco
- E22 Ruggine
- E23 Rock silver
- E24 Rock copper
- E25 Rock cemento

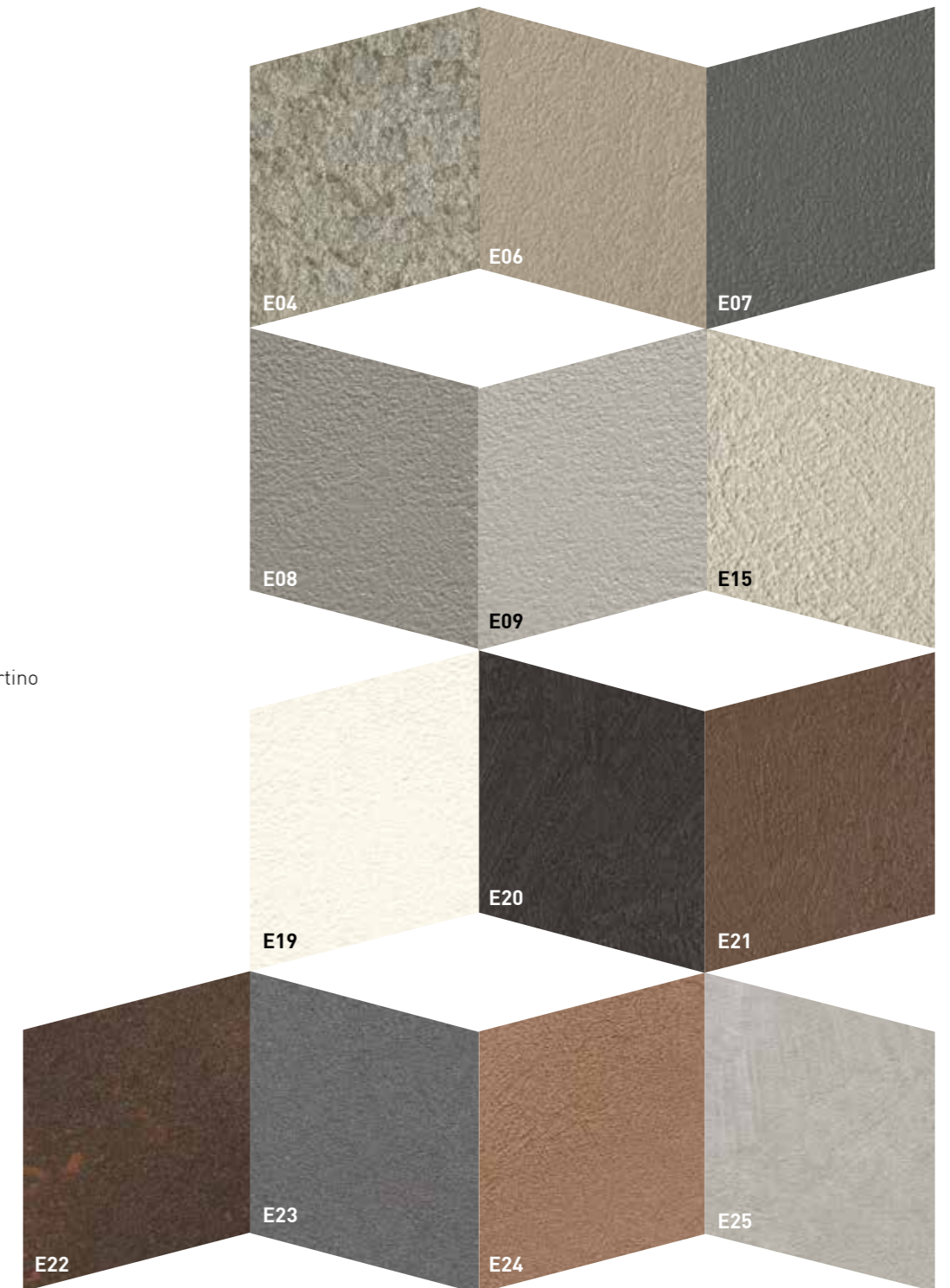

FINITURE / FINITIONS / FINISHES

La personalizzazione del prodotto dipende molto dalla scelta della finitura che si integra con forma e disegno e ne determina la sua "riuscita". Per la nostra collezione proponiamo un materiale nobile come il legno: rovere vecchio naturale e grigio dalle venature accentuate.

La personnalisation du produit dépend beaucoup du choix de la finition qui s'intègre avec la forme et le design et en détermine la "réussite". Pour notre collection, nous proposons un matériel noble comme le bois: vieux chêne gris ou naturel au veinage accentué.

The products customization is mostly depending on the choice of the finish which integrates with the shape and design and determines its "success". For our collection we propose a noble material such as wood; natural or gray old oak with accentuated woodgrains.

LEGNO IMPIALLACCIATO / PLACAGE BOIS / VENEER WOOD

- W02 Rovere grigio
- W03 Rovere tabacco
- W04 Rovere nodato
- W06 Rovere juta
- W07 Rovere fumé



- W10 Noce Canaletto



LEGNO MASSICCIO / BOIS MASSIF / SOLID WOOD

- W21 Rovere vecchio massiccio termotrattato
- W32 Rovere vecchio massiccio naturale
- W33 Rovere vecchio massiccio grigio



FINITURE / FINITIONS / FINISHES

NOBILITATO / MÉLAMINE / MELAMINE

- N20 Natural halifax oak
- N23 Cemento
- N24 Ardesia
- N25 Vintage chiaro
- N30 Morera
- N33 Resina silver
- N34 Resina grigio cenere
- N35 Rovere nodato caramel
- N36 Olmo moka
- N40 Noce Canaletto
- N42 Rovere nero
- N43 Bianco spatolato
- N44 Bianco statuario venato
- N45 Diamond cream
- N46 Pietra grey

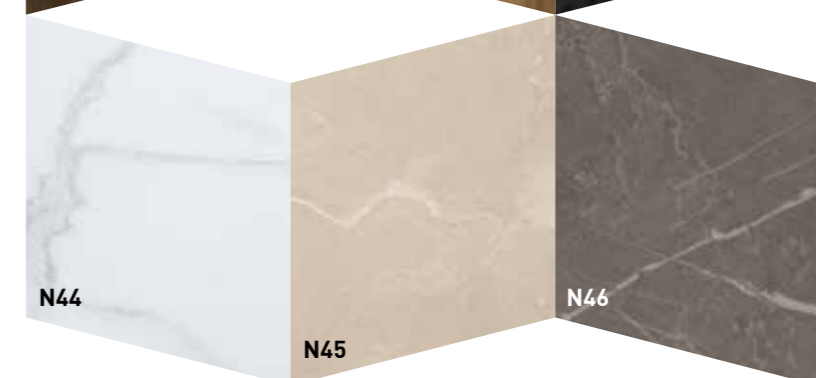

FINITURE / FINITIONS / FINISHES

LACCATO OPACO / LAQUÉ MAT / MATT LACQUER

- L51 Bianco luce
- L52 Bianco panna
- L53 Bianco vela
- L54 Grigio corda
- L55 Grigio canapa
- L59 Rosso aragosta
- L60 Tortora

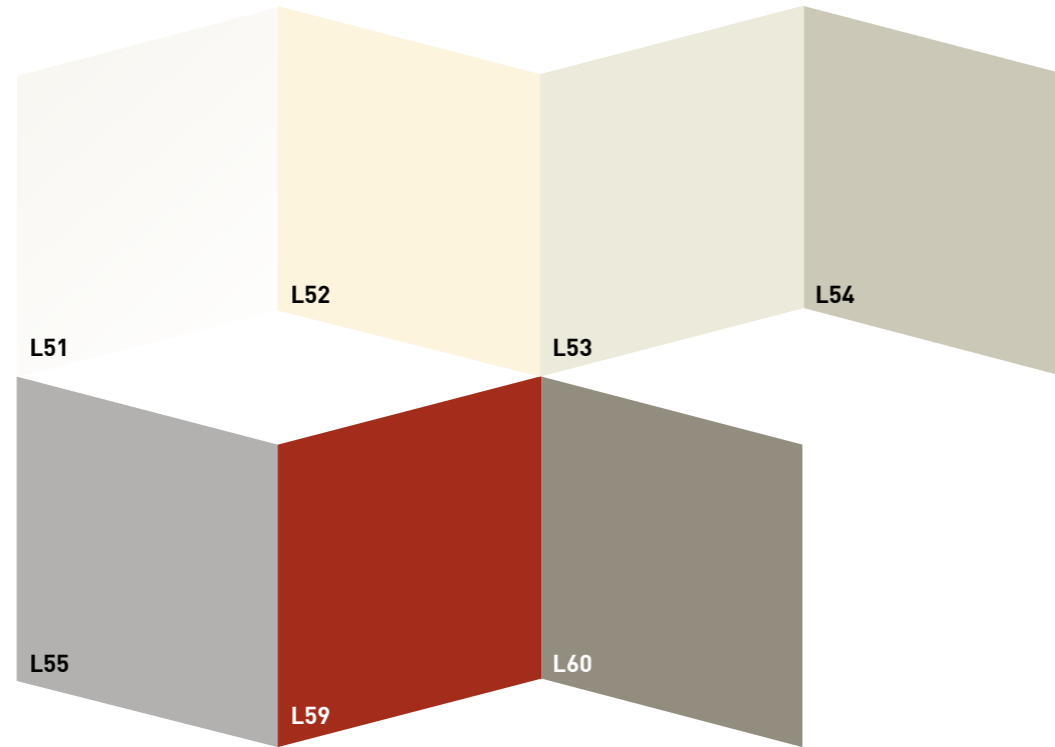

LACCATO LUCIDO / LAQUÉ BRILLANT / HIGH GLOSS LACQUER

- L01 Bianco luce



LACCATO PORO APERTO / LAQUÉ PORES OUVERTS / OPEN PORE LACQUER

- L31 Bianco luce
- L32 Bianco panna
- L33 Bianco vela
- L34 Grigio corda
- L35 Grigio canapa
- L39 Rosso aragosta
- L40 Tortora

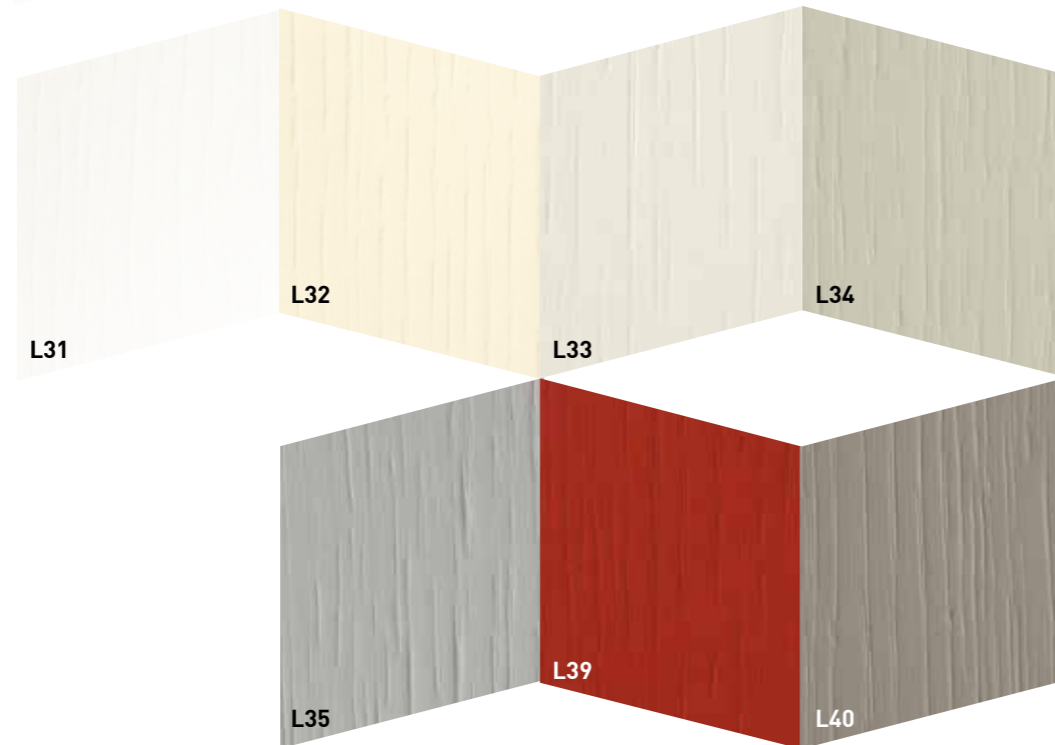

FINITURE / FINITIONS / FINISHES

CERAMICA / CÉRAMIQUE / CERAMIC

- K 01 Fokos Sale
- K 02 Fokos Terra
- K 03 Fokos Piombo
- K 04 Noir Desir Lucido
- K 05 Bianco Statuario Venato Lucido
- K 06 Diamond Cream Lucido
- K 07 Pietra Grey Lucida
- K 09 Oxide Nero
- K 10 Oxide Bianco
- K 11 Pietra Savoia Antracite
- K 12 Pietra di Savoia Grigio Perla
- K 13 Calacatta Gold Lucido
- K 14 Emperador Lucido
- K 15 Noir Desir Opaco
- K 16 Pietra Grey Opaco
- K 17 Calacatta Gold Opaco
- K 18 Bianco Statuario Venato Opaco
- K 19 Diamond Cream Opaco
- K 20 Emperador Opaco

LAMINAM
SUPERIOR NATURAL SURFACES

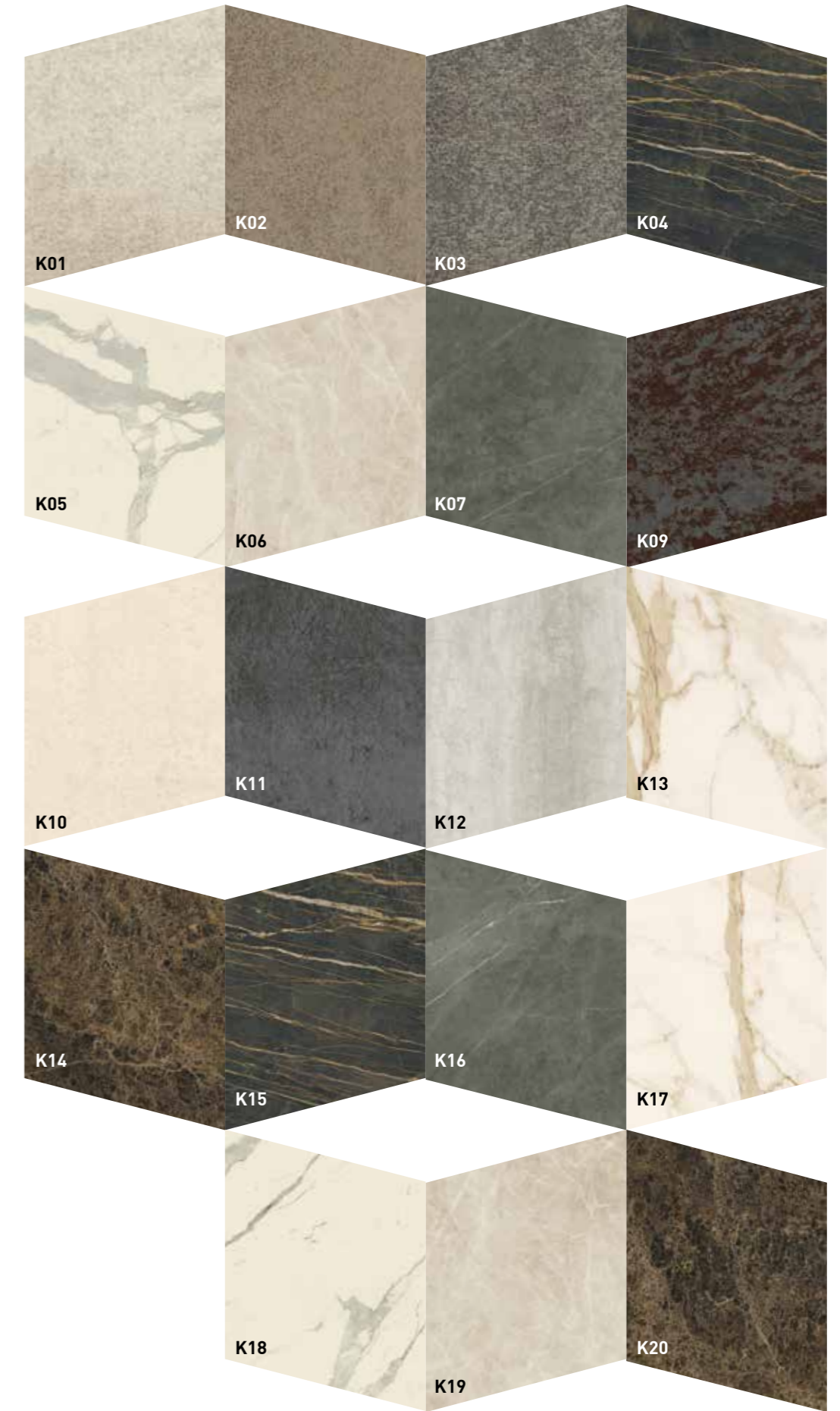

FINITURE / FINITIONS / FINISHES

Ad arricchire la vasta gamma di trasformabili, consolle e tavolini contribuisce decisamente la collezione di sedie Altacom per le quali sono disponibili rivestimenti in pelle, ecopelle ed ecopelle nabuk nelle nuance naturali del sabbia e del bianco o a contrasto la scelta del nero o del grafite.

À enrichir la gamme de tables relevables, consoles et tables repas contribue de manière décisive la collection de chaises Altacom pour lesquelles sont disponibles les revêtements en cuir, faux-cuir et faux-cuir nabuk dans les tons naturels du sable et du blanc ou, en contraste, le choix du noir ou du graphite.

To enrich the wide range of transforming tables, console-tables and dining tables, the collection of Altacom chairs gives its decided contribute: for them are available leather, eco-leather and nabuk eco-leather coverings in the natural nuances of sand and white or, as contrast, the choice of black or graphite.

CUOINETTO / CROÛTE DE CUIR / SPLIT LEATHER

- C01 Bianco
- C02 Avorio
- C03 Sand
- C05 Grigio chiaro
- C08 Moka
- C09 Grigio titanio
- C10 Nero
- C11 Tortora

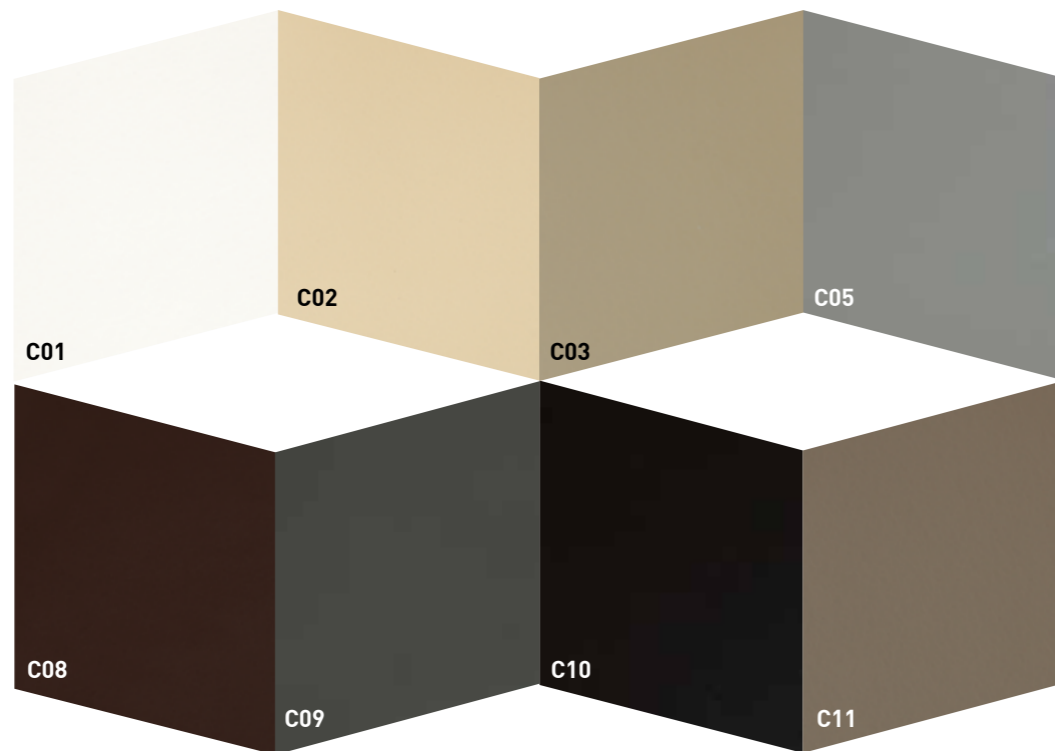

FINITURE / FINITIONS / FINISHES

PELLE / CUIR / LEATHER

- P11 Nero
- P15 Bianco ottico
- P16 Sabbia
- P17 Grafite

ECOPELLE / ECO-CUIR / SOFT ECO-LEATHER

- EC01 Bianco
- EC37 Sabbia
- EC62 Grafite
- EC91 Nero

ECOPELLE NABUK / ECO-CUIR NABUK / SOFT ECO-LEATHER NABUK

- NB07 Grigio
- NB17 Tortora
- NB08 Bianco

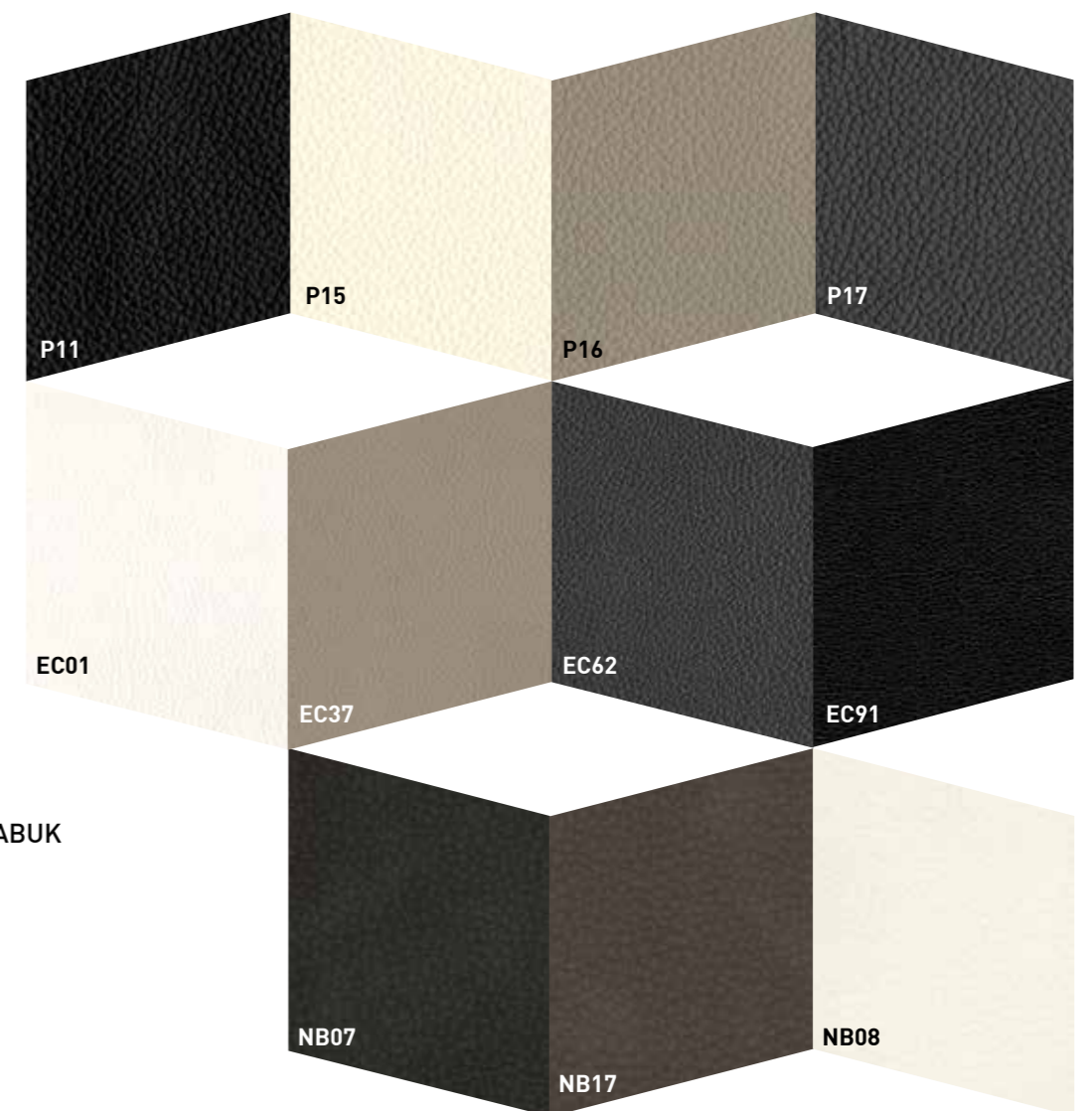

Thanks to:

D.Home

Matteo Pala

H & Co Home & Contract

Vuzeta

Compar

Arsenale sas è conforme ai requisiti di:
ISO9001 / UNI EN ISO 9001:2015
Certificato N.IT18/0167 - Sistema SGS



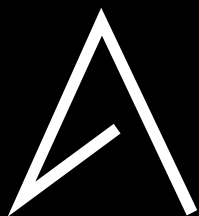

ALTACOM

Arsenale S.a.s. di Mucelli Angelo & C. | Via dell'Artigianato, 10 e 12 | 30024 Musile di Piave, VE Italy
Tel. +39 0421 52468 Fax +39 0421 334007

www.altacomitalia.it info@altacomitalia.it