



cattelan
italia

9

COLLECTION 2019



COLLECTION 2019

INDEX BOOK 9

TAVOLI

Dining Tables_Tables
Mesas_Tische_Стол

- 44 ATLANTIS CrystalArt
- 42 ATLANTIS Keramik
- 38 ATLANTIS Wood
- 26 DRAGON CrystalArt
- 22 DRAGON Keramik
- 28 DRAGON Wood
- 16 DRAGON Keramik Premium
- 10 MARATHON
- 62 RIBOT Keramik Bistrot
- 58 SATURNO Keramik Bistrot
- 52 SOHO Keramik Premium
- 56 SPYDER Keramik Premium
- 48 STRATOS Keramik Premium
- 34 SKORPIO CrystalArt
- 30 SKORPIO Keramik

CONSOLLE

Consoles_Consoles
Consolas_Konsolen_Консоли

- 76 SKYLINE Consolle Wood C
- 71 TERMINAL Consolle Keramik Premium
- 67 WESTIN Consolle Keramik Premium

SCRIVANIA

Desk_Bureaux_Escritorio_Schreibtische
Письменные Столы

- 80 WOLF Keramik

SEDIE

Chairs_Chaises_Sillas_Stühle_Стулья

- 95 BELINDA B
- 106 DUMBO Wood
- 89 FLAMINGO
- 92 FLAMINGO Cantilever
- 85 GINEVRA
- 100 KELLY Cantilever
- 96 TINA
- 104 WENDY

SGABELLI

Stools_Tabourets_Taburetes
Barhocker_Барные Стулья

- 108 ISABEL Sgabello ML

LIBRERIE

Bookcases_Bibliothèques
Estanterías_Bücherregale_Библиотеки

- 134 NAUTILUS
- 141 PIQUANT
- 142 WALLY

MADIE

Sideboards_Crédences
Aparadores_Sideboards_Буфеты

- 118 BOUTIQUE
- 110 CARNABY
- 128 CHELSEA
- 115 KAYAK
- 125 VOYAGER

PORTA TV

Tv Units_Porte-Tv_Muebles Tv
Tv-Träger_Подставка Для ТВ

- 133 ASTON TV

SPECCHI

Mirrors_Miroirs_Espejos_Spiegel_Зеркала

- 152 AFRICA
- 152 AFRICA MAGNUM
- 150 HAWAII Magnum
- 148 WISH Magnum
- 145 WISH S

TAVOLINI

Coffee Tables_Tables Basses
Mesitas_Couchtische_Журнальные Столики

- 168 AMERIGO
- 154 BILLY / BILLY Keramik
- 156 BENNY Keramik
- 164 IDEM
- 180 ORLANDO
- 174 PEYOTE
- 178 STING BB
- 172 STEP
- 177 YAGO

LAMPADE

Lamps_Lustres_Lámparas
Hängelampen_Люстры

- 191 BAMBOO
- 194 CIRCUIT
- 192 LORD
- 188 PHOENIX
- 183 PLANETA
- 199 TWIN

TAPPETI

Rugs_Tapis_Alfombras
Teppiche_Ковры

- 200 CHENNAI
- 203 MUMBAI

COMODINO

Nightstands_Commodos_Mesitas de Noche
Nachttische_Тумбочки

- 204 BIAGIO

LETTO

Beds_Lits_Camas_Betten_Кровати

- 207 MARLON





TAVOLI
TABLES



ATLANTIS CrystalArt page 44



ATLANTIS Keramik page 42



ATLANTIS Wood page 38



MARATHON page 10



SOHO Keramik Premium page 52



SPYDER Keramik Premium page 56

BISTROT
BISTROT



RIBOT Keramik Bistrot page 62



SATURNO Keramik Bistrot page 58

CONSOLLE
CONSOLES



SKYLINE Consolle Wood C page 76



TERMINAL Consolle Keramik Premium page 71



WESTIN Consolle Keramik Premium page 67



DRAGON CrystalArt page 26



DRAGON Keramik page 22



DRAGON Wood page 28



DRAGON Keramik Premium page 16



STRATOS Keramik Premium page 48



SKORPIO CrystalArt page 34



SKORPIO Keramik page 30

SCRIVANIA
DESK



WOLF Keramik page 80

**SEDIE
CHAIRS**



BELINDA B page 95



DUMBO Wood page 106



FLAMINGO page 89



WENDY page 104

**SGABELLI
STOOLS**



ISABEL Sgabello ML page 108

**MADIE
SIDEBOARDS**



BOUTIQUE page 118



CARNABY page 110



CHELSEA page 128

**SPECCHI
MIRRORS**



AFRICA page 152



WISH S page 145



FLAMINGO Cantilever page 92



GINEVRA page 85



KELLY Cantilever page 100



TINA page 96

**LIBRERIE
BOOKCASES**



NAUTILUS page 134



PIQUANT page 141



WALLY page 142



KAYAK page 115



VOYAGER page 125

**PORTA TV
TV UNIT**



ASTON TV page 133

**SPECCHI MAGNUM
MAGNUM MIRRORS**



AFRICA Magnum page 152



HAWAII Magnum page 150



WISH Magnum page 148

TAVOLINI
COFFEE TABLES



AMERIGO page 168



BILLY / BILLY Keramik page 154



BENNY Keramik page 156



STEP page 172



YAGO page 177

LAMPADE
LAMPS



BAMBOO page 191



CIRCUIT page 194



CIRCUIT page 196

LAMPADE
DA TAVOLO E DA TERRA
TABLE LAMPS AND
FLOOR LAMPS



PLANETA - P page 186



PLANETA - T page 187



TWIN page 199



IDEM

page 164



ORLANDO

page 180



PEYOTE

page 174



STING BB

page 178

TAPPETI
RUGS



CHENNAI

page 200



MUMBAI

page 203



LORD

page 192



PHOENIX

page 188



PLANETA

page 183



PLANETA - A

page 187

COMODINO
NIGHTSTAND



BIAGIO

page 204

LETTO
BED



MARLON

page 207

MARATHON

Design **Andrea Lucatello**

Tavolo con base in massello di noce Canaletto, frassino tinto rovere bruciato o frassino laccato poro aperto nero e acciaio verniciato gofrato titanio o nero. Piano in cristallo 15mm trasparente, trasparente extrachiaro, o trasparente extrachiaro con bordo bisellato.

Table with base in solid Canaletto walnut, burned oak stained ashwood or open pore matt black painted ashwood and titanium or black embossed lacquered steel. Top 15mm thick in clear glass, extra clear glass or extra clear with bevelled edges.

Table avec base en massif en noyer Canaletto, frêne teinté rouvre brûlé ou laqué noir opaque pore ouvert et acier gaufré titan ou noir. Plateau de 15 mm en verre clair, verre extra-clair ou verre extra-clair avec bords biseautés.

Mesa con base en macizo de nogal Canaletto, fresno pintado roble ahumado o fresno lacado a poro abierto negro y acero barnizado gofrado titanio o negro. Sobre en cristal 15mm transparente, transparente extraclaro o transparente extraclaro con canto biselado.

Tisch mit Basis aus Massivholz Nussbaum Canaletto, Esche "verbrannte Eiche" lackiert oder Esche offenporig matt schwarz lackiert und Stahl lackiert titan oder schwarz gaufriert. 15 mm Platte in Klarglas, Glas extra hell oder Glas extra hell mit Kanten facettiert.

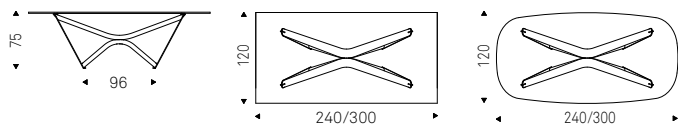



MARATHON table with base in solid burned oak stained ashwood, titanium embossed lacquered steel and extra clear glass top.
SOFIA chair with wenghe stained beech frame and soft leather 950 Tortora. PHOENIX lamp. NAUTILUS bookcase in titanium embossed lacquered steel. RADJA rug.





MARATHON table with base in solid burned oak stained ashwood, titanium embossed lacquered steel and extra clear glass top - SOFIA chair with wenghè stained beech frame and soft leather
950 Tortora - PHOENIX lamp - NAUTILUS bookcase in titanium embossed lacquered steel - RADJA rug





DRAGON Keramik Premium
Design Paolo Cattelan

Tavolo con base in acciaio verniciato gofrato titanio, graphite o nero. Piano in ceramica Marmi nei colori Calacatta, Alabastro, Ardesia, Golden Calacatta opaco, Golden Calacatta lucido, Portoro opaco, Portoro lucido, Sahara Noir lucido, Emperador o Makalu con profilo inferiore arrotondato e verniciato nero o Brushed Bronze.

Table with titanium, graphite or black embossed lacquered steel base. Top in ceramic Marmi Calacatta, Alabastro, Ardesia, matt Golden Calacatta, glossy Golden Calacatta, matt Portoro, glossy Portoro, glossy Sahara Noir, Emperador or Makalu with black or Brushed Bronze lacquered and rounded lower profile.

Table avec base en acier gaufré titane, graphite ou noir. Plateau en céramique Marmi dans les couleurs Calacatta, Alabastro, Ardesia, Golden Calacatta opaque, Golden Calacatta brillant, Portoro opaque, Portoro brillant, Sahara Noir brillant, Emperador ou Makalu avec profil inférieur arrondi laqué noir ou Brushed Bronze.

Mesa con base en acero barnizado gofrado titanio, graphite o negro. Sobre en cerámica Marmi colores Calacatta, Alabastro, Ardesia, Golden Calacatta mate, Golden Calacatta brillo, Portoro mate, Portoro brillo, Sahara Noir brillo, Emperador o Makalu y perfil inferior redondeado barnizado negro o Brushed Bronze.

Tisch mit Basis aus Stahl lackiert titan, graphite oder schwarz gaufriert. Platte aus Keramik Marmi in den Farben Calacatta, Alabastro, Ardesia, matt Golden Calacatta, glänzend Golden Calacatta, matt Portoro, glänzend Portoro, glänzend Sahara Noir, Emperador oder Makalu mit schwarz oder Brushed Bronze lackierten abgerundeten Profil.

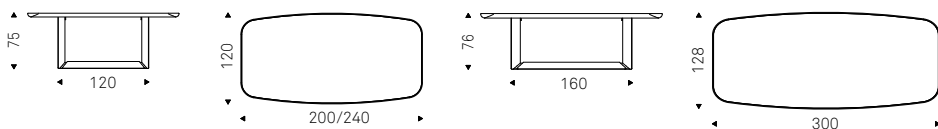

DRAGON KERAMIK PREMIUM table with titanium base and top in ceramic matt Portoro and Brushed Bronze lower profile

DRAGON
Keramik Premium





DRAGON KERAMIK PREMIUM table with titanium base and top in ceramic matt Portoro and Brushed Bronze lower profile -
MAGDA chair with burned oak stained ashwood frame and soft leather 948 Lino - BAMBOO lamp - RADJA rug - NAUTILUS bookcase in titanium embossed lacquered steel







DRAGON Keramik

Design Paolo Cattelan

Tavolo con base in acciaio verniciato gofrato titanio, graphite o nero. Piano in ceramica Marmi nei colori Calacatta, Alabastro, Ardesia, Golden Calacatta opaco, Golden Calacatta lucido, Portoro opaco, Portoro lucido, Sahara Noir lucido, Emperador o Makalu.

Table with titanium, graphite or black embossed lacquered steel base. Top in ceramic Marmi Calacatta, Alabastro, Ardesia, matt Golden Calacatta, glossy Golden Calacatta, matt Portoro, glossy Portoro, glossy Sahara Noir, Emperador or Makalu.

Table avec base en acier gaufré titane, graphite ou noir. Plateau en céramique Marmi dans les couleurs Calacatta, Alabastro, Ardesia, Golden Calacatta opaque, Golden Calacatta brillant, Portoro opaque, Portoro brillant, Sahara Noir brillant, Emperador ou Makalu.

Mesa con base en acero barnizado gofrado titanio, graphite o negro. Sobre en cerámica Marmi colores Calacatta, Alabastro, Ardesia, Golden Calacatta mate, Golden Calacatta brillo, Portoro mate, Portoro brillo, Sahara Noir brillo, Emperador o Makalu.

Tisch mit Basis aus Stahl lackiert titan, graphite oder schwarz gaufriert. Platte aus Keramik Marmi in den Farben Calacatta, Alabastro, Ardesia, matt Golden Calacatta, glänzend Golden Calacatta, matt Portoro, glänzend Portoro, glänzend Sahara Noir, Emperador oder Makalu.

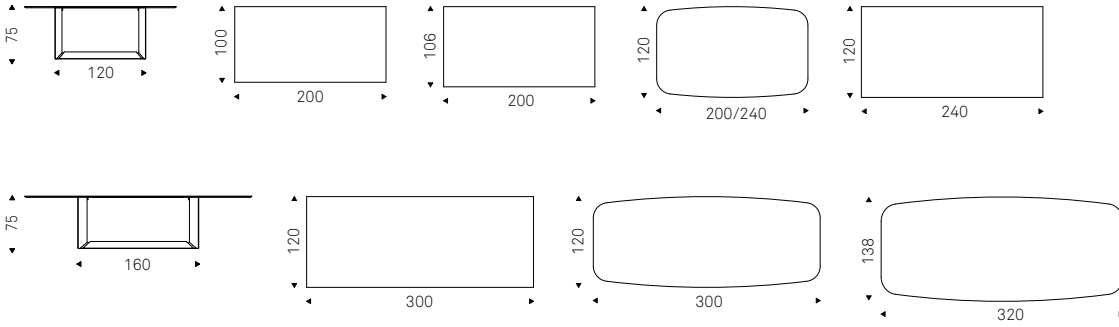







DRAGON CrystalArt

Design Paolo Cattelan

Tavolo con base in acciaio verniciato gofrato titanio, graphite o nero. Piano in cristallo 12mm extrachiario bisellato con stampa artistica decorativa.

Table with titanium, graphite or black embossed lacquered steel base. Top 12mm thick in extra clear bevelled glass with artistic decorative printing.

Table avec base en acier gaufré titane, graphite ou noir. Plateau en verre 12mm extra-clair avec bords biseautés et impression artistique décorative.

Mesa con base en acero barnizado gofrado titanio, graphite o negro. Sobre en cristal 12mm extraclaro biselado con impresión artística decorativa.

Tisch mit Basis aus Stahl lackiert titan, graphite oder schwarz gaufriert. 12 mm Glasplatte extra hell facettiert mit schmückendem Kunstdruck.

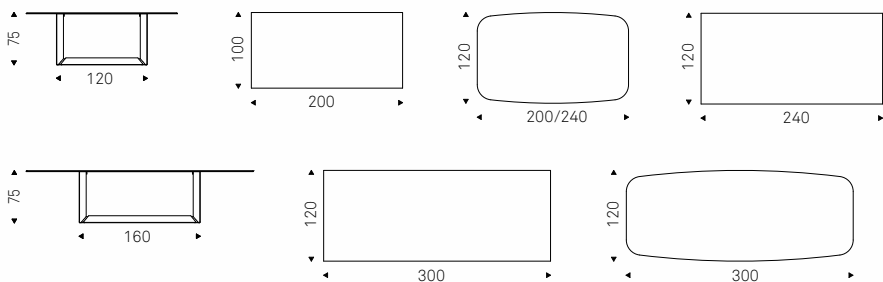



DRAGON Wood

Design Paolo Cattelan

Tavolo con base in acciaio verniciato gofrato titanio, graphite o nero. **Versione "A"**: piano con bordi obliqui in legno noce Canaletto, rovere Heritage o rovere naturale, il piano 200x100 ha lo spessore di 4cm, il 240x120 e il 300x120 di 5cm. **Versione "S"**: piano con bordi irregolari in massello di noce Canaletto, rovere bruciato o rovere naturale, spessore 4cm. **Versione "B"**: piano a botte con bordi bisellati in noce Canaletto o rovere bruciato. **Versione "C"**: piano in noce Canaletto con profilo inferiore arrotondato e verniciato nero o Olmo tinto poro aperto nero opaco con profilo inferiore arrotondato verniciato Brushed Bronze. Misure speciali a richiesta.

Table with titanium, graphite or black embossed lacquered steel base. **Version "A"**: top with angled edges in Canaletto walnut, Heritage oak or natural oak. 4cm thick wooden top on 200x100 versions and 5cm on 240x120 and 300x120 versions. **Version "S"**: top with irregular solid wood edges in Canaletto walnut, burned oak or natural oak, 4cm thickness. **Version "B"**: barrel top with angled edges in Canaletto walnut or burned oak. **Version "C"**: top in Canaletto walnut with black lacquered and rounded lower profile or elm open pore matt black with Brushed Bronze lacquered and rounded lower profile. Special sizes for top on demand.

Table avec base en acier gaufré titane, graphite ou noir. **Version "A"**: plateau avec bords biseautés en bois noyer Canaletto, rovere Heritage ou rovere naturel. Les plateaux 200x100 ont une épaisseur de 4cm, les plateaux 240x120 et 300x120 de 5cm. **Version "S"**: plateau en noyer Canaletto, rovere brulé ou rovere naturel avec bords irréguliers en bois massif. Épaisseur 4 cm. **Version "B"**: plateau avec bords biseautés en noyer Canaletto ou rovere brulé. **Version "C"**: plateau en noyer Canaletto avec profil inférieur arrondi laqué noire ou Orme laqué noir opaque pore ouvert avec profil inférieur arrondi laqué Brushed Bronze. Sur demande, dimensions spéciaux pour le plateau.

Mesa con base en acero barnizado gofrado titanio, graphite o negro. **Versión "A"**: sobre con bordes oblicuos en nogal Canaletto, roble Heritage o roble natural. Grosor sobre de 4 cm en las medidas 200x100 cm y de 5 cm en las medidas 240x120 cm y 300x120 cm. **Versión "S"**: sobre en nogal Canaletto, roble ahumado o roble natural con bordes irregulares en macizo. Grosor 4 cm. **Versión "B"**: sobre con bordes biselados en nogal Canaletto o roble ahumado. **Versión "C"**: sobre en nogal Canaletto y perfil inferior redondeado barnizado negro u Olmo barnizado negro mate a poro abierto y perfil inferior redondeado barnizado Brushed Bronze. Medidas especiales disponibles sobre pedido.

Tisch mit Basis aus Stahl lackiert titan, graphite oder schwarz gaufriert. **Versión "A"**: Platte mit schrägen Kanten in Nussbaum Canaletto, Eiche Heritage oder Natur Eiche. Die Platte 200x100 ist 4 cm Dick, die Platten in 240x120 und 300x120 sind 5 cm Dick. **Versión "S"**: Platte in Nussbaum Canaletto, "verbrannte Eiche" oder Natur Eiche mit massiven und unregelmäßigen Kanten. 4 cm Dicke. **Versión "B"**: Platte mit schrägen Kanten aus Nussbaum Canaletto oder "verbrannte Eiche". **Versión "C"**: Platte aus Nussbaum Canaletto mit schwarz lackierten abgerundeten Profil oder Ulme offenporig lackiert schwarz matt mit Brushed Bronze lackierten abgerundeten Profil. Sondermasse auf Anfrage.

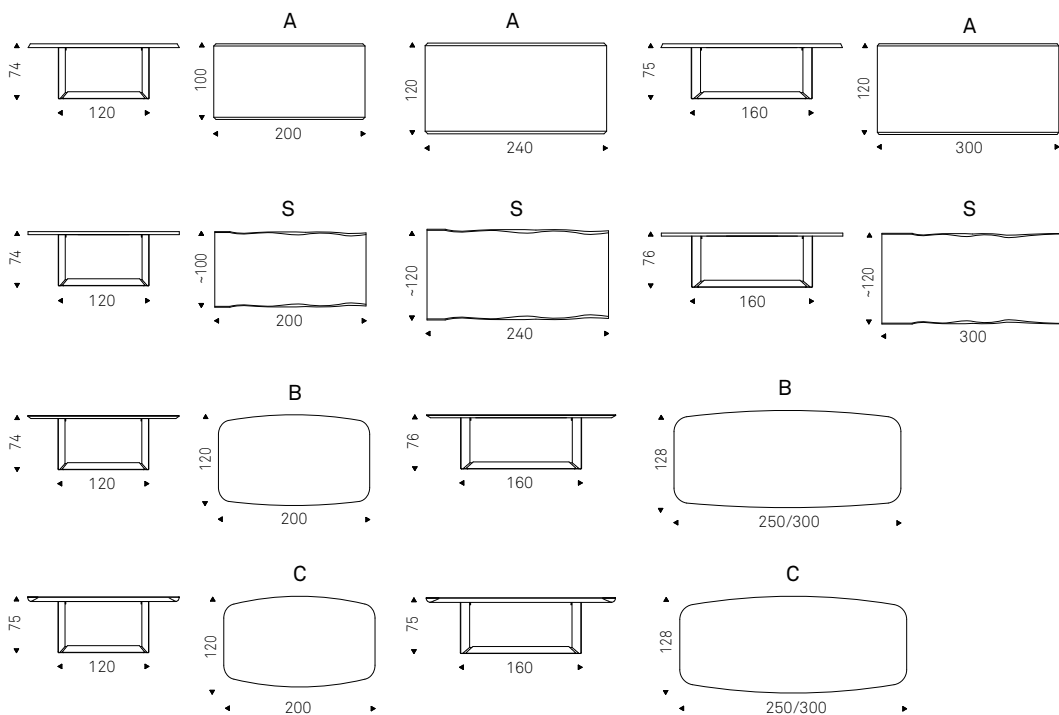



SKORPIO Keramik

Design **A. Lucatello**

P. Cattelan

Tavolo con base in acciaio verniciato trasparente, goffrato titanio, bianco, nero o graphite o Brushed Bronze. Piano in ceramica Marmi nei colori Makalu, Emperador, Calacatta, Alabastro, Ardesia, Golden Calacatta opaco, Golden Calacatta lucido, Portoro opaco, Portoro lucido, Sahara Noir lucido o ceramica Brown Zinc.

Table with transparent varnished metal base, titanium, white, black, or graphite embossed lacquered steel or Brushed Bronze lacquered steel. Top in ceramic Marmi Makalu, Emperador, Calacatta, Alabastro, Ardesia, matt Golden Calacatta, glossy Golden Calacatta, matt Portoro, glossy Portoro, glossy Sahara Noir or Brown Zinc.

Table avec base en acier laqué transparent, gaufré titane, blanc, noir ou graphite ou Brushed Bronze. Plateau en céramique Marmi dans les couleurs Makalu, Emperador, Calacatta, Alabastro, Ardesia, Golden Calacatta opaque, Golden Calacatta brillant, Portoro opaque, Portoro brillant, Sahara Noir brillant ou Brown Zinc.

Mesa con base en acero barnizado transparente, gofrado titanio, blanco, negro o graphite o Brushed Bronze. Sobre en cerámica Marmi colores Makalu, Emperador, Calacatta, Alabastro, Ardesia, Golden Calacatta mate, Golden Calacatta brillo, Portoro mate, Portoro brillo, Sahara Noir brillo o cerámica Brown Zinc.

Esstisch mit Basis aus Metall lackiert transparent oder titan, weiß, schwarz oder graphite gaufriert oder Brushed Bronze. Platte in Keramik Marmi in den Farben Makalu, Emperador, Calacatta, Alabastro, Ardesia, matt Golden Calacatta, glänzend Golden Calacatta, matt Portoro, glänzend Portoro, glänzend Sahara Noir oder Keramik Brown Zinc.

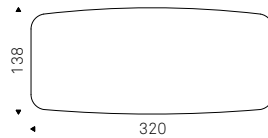
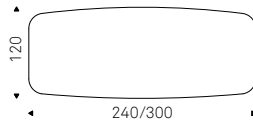
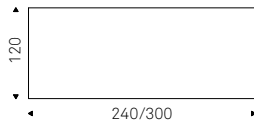
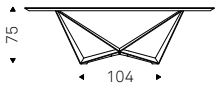
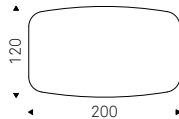
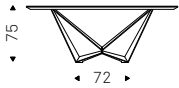







SKORPIO CrystalArt

Design **A. Lucatello**
P. Cattelan

Tavolo con base in acciaio verniciato trasparente, gofrato titanio, bianco, nero o graphite o Brushed Bronze. Piano in cristallo 12mm extrachiaro bisellato con stampa artistica decorativa.

Table with transparent varnished metal base, titanium, white, black, or graphite embossed lacquered steel or Brushed Bronze lacquered steel. Top 12mm thick in extra clear bevelled glass with artistic decorative printing.

Table avec base en acier laqué transparent, gaufré titane, blanc, noir ou graphite ou Brushed Bronze. Plateau en verre 12mm extra-clair avec bords biseautés et impression artistique décorative.

Mesa con base en acero barnizado transparente, gofrado titanio, blanco, negro o graphite o Brushed Bronze. Sobre en cristal 12mm extraclaro biselado con impresión artística decorativa.

Esstisch mit Basis aus Metall lackiert transparent oder titan, weiß, schwarz oder graphite gaufriert oder Brushed Bronze. 12 mm Glasplatte extra hell facettiert mit schmückendem Kunstdruck.

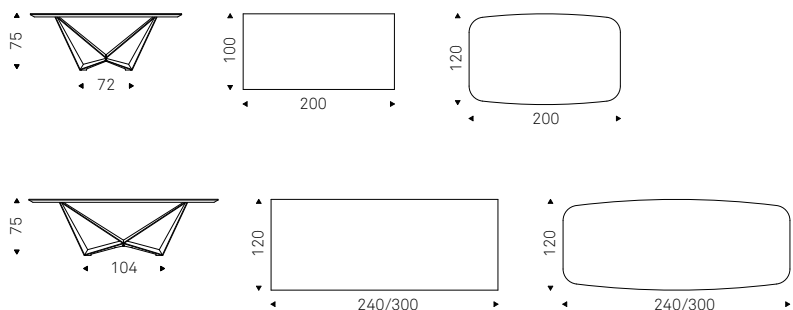







ATLANTIS Wood

Design Paolo Cattelan

Tavolo con base in acciaio verniciato gofrato titanio, graphite o nero. **Versione "A"**: piano con bordi obliqui in legno noce Canaletto, rovere Heritage o rovere naturale. **Versione "S"**: piano con bordi irregolari in massello di noce Canaletto, rovere bruciato o rovere naturale. **Versione "B"**: piano a botte con bordi bisellati in noce Canaletto o rovere bruciato. Misure speciali a richiesta.

Table with titanium, graphite or black embossed lacquered steel base. **Version "A"**: top with angled edges in Canaletto walnut, Heritage oak or natural oak. **Version "S"**: top with irregular solid wood edges in Canaletto walnut, burned oak or natural oak. **Version "B"**: barrel top with angled edges in Canaletto walnut or burned oak.

Table avec base en acier gaufré titane, graphite ou noir. **Version "A"**: plateau avec bords biseautés en bois noyer Canaletto, rovere Heritage ou rovere naturel. **Version "S"**: plateau en noyer Canaletto, rovere brûlé ou rovere naturel avec bords irréguliers en bois massif. **Version "B"**: plateau avec bords biseautés en noyer Canaletto ou rovere brûlé.

Mesa con base en acero barnizado gofrado titanio, graphite o negro. **Versión "A"**: sobre con bordes oblicuos en nogal Canaletto, roble Heritage o roble natural. **Versión "S"**: sobre en nogal Canaletto, roble ahumado o roble natural con bordes irregulares en macizo. **Versión "B"**: sobre con bordes biselados en nogal Canaletto o roble ahumado. Medidas especiales disponibles sobre pedido.

Tisch mit Basis aus Stahl lackiert titan, graphite oder schwarz gaufriert. **Version "A"**: Platte mit schrägen Kanten in Nussbaum Canaletto, Eiche Heritage oder Natur Eiche. **Version "S"**: Platte in Nussbaum Canaletto, "verbrannte Eiche" oder Natur Eiche mit massiven und unregelmäßigen Kanten. **Version "B"**: Platte mit schrägen Kanten aus Nussbaum Canaletto oder "verbrannte Eiche". Sondermasse auf Anfrage.

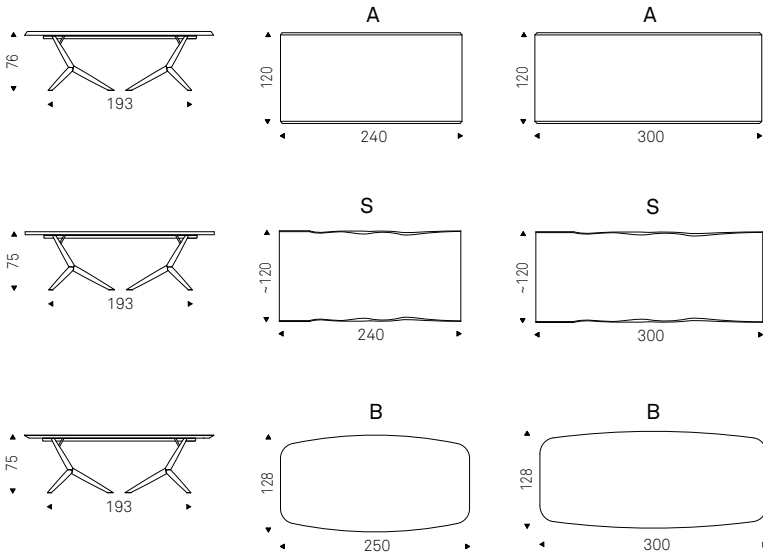





ATLANTIS WOOD B table with black base and burned oak top - BELINDA chair with burned oak stained ashwood frame and soft leather 951 Castoro - KIDAL lamp
CARNABY sideboard in smoked grey mirrored glass - REGAL mirror in fumé - MUMBAI rug



ATLANTIS Keramik
Design Paolo Cattelan

Tavolo con base in acciaio verniciato gofrato titanio, graphite o nero. Piano in ceramica Marmi nei colori Calacatta, Alabastro, Ardesia, Golden Calacatta opaco, Golden Calacatta lucido, Portoro opaco, Portoro lucido, Sahara Noir lucido, Emperador o Makalu.

Table with titanium, graphite or black embossed lacquered steel base. Top in ceramic Marmi Calacatta, Alabastro, Ardesia, matt Golden Calacatta, glossy Golden Calacatta, matt Portoro, glossy Portoro, glossy Sahara Noir, Emperador or Makalu.

Table avec base en acier gaufré titane, graphite ou noir. Plateau en céramique Marmi dans les couleurs Calacatta, Alabastro, Ardesia, Golden Calacatta opaque, Golden Calacatta brillant, Portoro opaque, Portoro brillant, Sahara Noir brillant, Emperador ou Makalu.

Mesa con base en acero barnizado gofrado titanio, graphite o negro. Sobre en cerámica Marmi colores Calacatta, Alabastro, Ardesia, Golden Calacatta mate, Golden Calacatta brillo, Portoro mate, Portoro brillo, Sahara Noir brillo, Emperador o Makalu.

Tisch mit Basis aus Stahl lackiert titan, graphite oder schwarz gaufriert. Platte aus Keramik Marmi in den Farben Calacatta, Alabastro, Ardesia, matt Golden Calacatta, glänzend Golden Calacatta, matt Portoro, glänzend Portoro, glänzend Sahara Noir, Emperador oder Makalu.



ATLANTIS KERAMIK table with black base and Makalu ceramic top



ATLANTIS CrystalArt
Design Paolo Cattelan

Tavolo con base in acciaio verniciato gofrato titanio, graphite o nero. Piano in cristallo 12mm extrachiario bisellato con stampa artistica decorativa.

Table with titanium, graphite or black embossed lacquered steel base. Top 12mm thick in extra clear bevelled glass with artistic decorative printing.

Table avec base en acier gaufré titane, graphite ou noir. Plateau en verre 12mm extra-clair avec bords biseautés et impression artistique décorative.

Mesa con base en acero barnizado gofrado titanio, graphite o negro. Sobre en cristal 12mm extraclaro biselado con impresión artística decorativa.

Tisch mit Basis aus Stahl lackiert titan, graphite oder schwarz gaufriert. 12 mm Glasplatte extra hell facettiert mit schmückendem Kunstdruck.

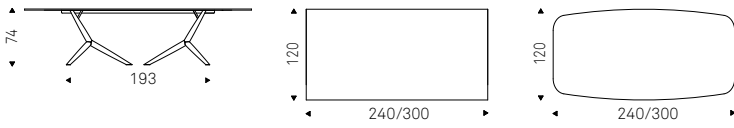



ATLANTIS CRYSTALART table with black base and extra clear glass with decorative printing top - DUMBO chair with matt black ashwood frame and soft leather 973 Nero
POSEIDON lamp - VOYAGER sideboard in mirrored frosted bronze glass



ATLANTIS CRYSTALART table with black base and extra clear glass with decorative printing top - DUMBO chair with matt black ashwood frame and soft leather 973 Nero
POSEIDON lamp - VOYAGER sideboard in mirrored frosted bronze glass



STRATOS Keramik Premium
Design Studio Kronos

Tavolo con base in acciaio verniciato gofrato titanio, graphite o nero. Piano in ceramica Marmi nei colori Calacatta, Alabastro, Ardesia, Golden Calacatta opaco, Golden Calacatta lucido, Portoro opaco, Portoro lucido, Sahara Noir lucido, Emperador o Makalu con profilo inferiore arrotondato e verniciato nero o Brushed Bronze.

Table with base in titanium, black or graphite embossed lacquered steel. Top in ceramic Marmi Calacatta, Alabastro, Ardesia, matt Golden Calacatta, glossy Golden Calacatta, matt Portoro, glossy Portoro, glossy Sahara Noir, Emperador or Makalu with black or Brushed Bronze lacquered and rounded lower profile.

Table avec base en acier gaufré titane, noir ou graphite. Plateau en céramique Marmi dans les couleurs Calacatta, Alabastro, Ardesia, Golden Calacatta opaque, Golden Calacatta brillante, Portoro opaque, Portoro brillant, Sahara Noir brillant, Emperador ou Makalu avec profil inférieur arrondi laqué noir ou Brushed Bronze.

Mesa con base en acero barnizado gofrado titanio, negro o graphite. Sobre en cerámica Marmi colores Calacatta, Alabastro, Ardesia, Golden Calacatta mate, Golden Calacatta brillo, Portoro mate, Portoro brillo, Sahara Noir brillo, Emperador o Makalu y perfil inferior redondeado barnizado negro o Brushed Bronze.

Esstisch mit Basis in Edelstahl lackiert titan, schwarz oder graphite gaufriert. Platte aus Keramik Marmi in den Farben Calacatta, Alabastro, Ardesia, matt Golden Calacatta, glänzend Golden Calacatta, matt Portoro, glänzend Portoro, glänzend Sahara Noir, Emperador oder Makalu mit schwarz oder Brushed Bronze lackierten abgerundeten Profil.

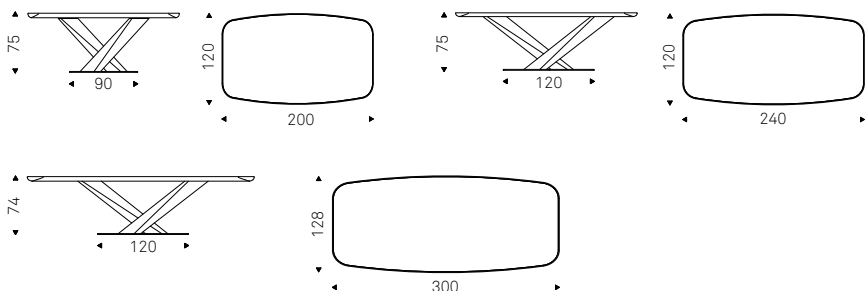







STRATOS KERAMIK PREMIUM table with titanium base and top in ceramic matt Golden Calacatta and Brushed Bronze lower profile
ISABEL chair in soft leather 951 Castoro - PLANETA lamp - RADJA rug

SOHO Keramik Premium

Design Brogliato &
Traverso - P. Cattelan

Tavolo con base in acciaio verniciato gofrato titanio, graphite o nero. Piano in ceramica Marmi nei colori Calacatta, Alabastro, Ardesia, Golden Calacatta opaco, Golden Calacatta lucido, Portoro opaco, Portoro lucido, Sahara Noir lucido, Emperador o Makalu con profilo inferiore arrotondato e verniciato nero o Brushed Bronze.

Table with base in titanium, graphite or black embossed lacquered steel. Top in ceramic Marmi Calacatta, Alabastro, Ardesia, matt Golden Calacatta, glossy Golden Calacatta, matt Portoro, glossy Portoro, glossy Sahara Noir, Emperador or Makalu with black or Brushed Bronze lacquered and rounded lower profile.

Table avec base en acier gaufré titane, graphite ou noir. Plateau en céramique Marmi dans les couleurs Calacatta, Alabastro, Ardesia, Golden Calacatta opaque, Golden Calacatta brillant, Portoro opaque, Portoro brillant, Sahara Noir brillant, Emperador ou Makalu avec profil inférieur arrondi laqué noir ou Brushed Bronze.

Mesa con base en acero barnizado gofrado titanio, graphite o negro. Sobre en cerámica Marmi colores Calacatta, Alabastro, Ardesia, Golden Calacatta mate, Golden Calacatta brillo, Portoro mate, Portoro brillo, Sahara Noir brillo, Emperador o Makalu y perfil inferior redondeado barnizado negro o Brushed Bronze.

Esstisch mit Basis aus Metall lackiert titan, graphite oder schwarz gaufriert. Platte aus Keramik Marmi in den Farben Calacatta, Alabastro, Ardesia, matt Golden Calacatta, glänzend Golden Calacatta, matt Portoro, glänzend Portoro, glänzend Sahara Noir, Emperador oder Makalu mit schwarz oder Brushed Bronze lackierten abgerundeten Profil.

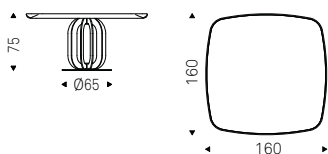



SOHO KERAMIK PREMIUM table with titanium base and top in glossy Sahara Noir ceramic and Brushed Bronze lower profile
BELINDA chair with burned oak stained ashwood frame and soft leather 948 Lino - PHOENIX lamp - MUMBAI rug - CHELSEA sideboard in titanium - AFRICA mirror in smoked grey glass





SOHO KERAMIK PREMIUM table with titanium base and top in glossy Sahara Noir ceramic and Brushed Bronze lower profile - BELINDA chair with burned oak stained ashwood frame and soft leather, 948 Lino - PHOENIX lamp - MUMBAI rug - CHELSEA sideboard in titanium - AFRICA mirror in smoked grey glass - NAUTILUS bookcase in titanium

SPYDER Keramik Premium

Design **P. Jackson P. Cattelan**

Tavolo con base in acciaio verniciato opaco bianco, nero, graphite, ottone anticato, inox lucido, noce Canaletto, dark wenghè o Rovere Heritage. Piano in ceramica Marmi nei colori Calacatta, Alabastro, Ardesia, Golden Calacatta opaco, Golden Calacatta lucido, Portoro opaco, Portoro lucido, Sahara Noir lucido, Emperador o Makalu con profilo inferiore arrotondato e verniciato nero o Brushed Bronze.

Table with base in matt white, black or graphite painted steel, or in wheateded brass or polished stainless steel, or with wooden base in Canaletto walnut, dark Wenghè or Heritage oak. Top in ceramic Marmi Calacatta, Alabastro, Ardesia, matt Golden Calacatta, glossy Golden Calacatta, matt Portoro, glossy Portoro, glossy Sahara Noir, Emperador or Makalu with black or Brushed Bronze lacquered and rounded lower profile.

Table avec base en acier laqué blanc opaque, noir opaque, graphite opaque, laiton antique, inox brillant, noyer Canaletto, dark wenghè ou rouvre Heritage. Plateau en céramique Marmi dans les couleurs Calacatta, Alabastro, Ardesia, Golden Calacatta opaque, Golden Calacatta brillant, Portoro opaque, Portoro brillant, Sahara Noir brillant, Emperador ou Makalu avec profil inférieur arrondi laqué noir ou Brushed Bronze.

Mesa con base en acero barnizado blanco, negro, graphite mate, latón, acero inox brillo, nogal Canaletto, dark wenghè o roble Heritage. Sobre en cerámica Marmi colores Calacatta, Alabastro, Ardesia, Golden Calacatta mate, Golden Calacatta brillo, Portoro mate, Portoro brillo, Sahara Noir brillo, Emperador o Makalu y perfil inferior redondeado barnizado negro o Brushed Bronze.

Tisch mit Basis aus lackiertem Stahl matt weiß, matt schwarz, matt graphite, Messing antik, glänzendem Edelstahl oder Nussbaum Canaletto, dark wenghè oder Eiche Heritage. Platte aus Keramik Marmi in den Farben Calacatta, Alabastro, Ardesia, matt Golden Calacatta, glänzend Golden Calacatta, matt Portoro, glänzend Portoro, glänzend Sahara Noir, Emperador oder Makalu mit schwarz oder Brushed Bronze lackierten abgerundeten Profil.

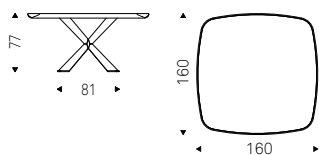



SPYDER KERAMIK PREMIUM table with black base and top in glossy Sahara Noir ceramic and Brushed Bronze lower profile

SATURNO Keramik Bistrot

Design Giorgio Cattelan

Tavolo bistrot con base in acciaio verniciato gofrato titanio, graphite o nero, e cornice del top in acciaio verniciato gofrato titanio, graphite o nero o Brushed Bronze. Piano in ceramica Marmi nei colori Calacatta, Alabastro, Ardesia, Portoro opaco, Portoro lucido, Emperador o Makalu.

Bistrot table with base in titanium, graphite or black embossed lacquered steel and top frame in titanium, graphite or black embossed lacquered steel or Brushed Bronze. Marmi Calacatta, Alabastro, Ardesia, matt Portoro, glossy Portoro, Emperador or Makalu ceramic top.

Table bistrot avec base en acier gaufré titane, graphite ou noir et bord du plateau en acier gaufré titane, graphite ou noir ou Brushed Bronze. Plateau en céramique Marmi dans les couleurs Calacatta, Alabastro, Ardesia, Portoro opaque, Portoro brillant, Emperador ou Makalu.

Mesa bistrot con base en acero barnizado gofrado titanio, graphite o negro y marco del sobre en acero barnizado gofrado titanio, graphite, negro o Brushed Bronze. Sobre en cerámica Marmi colores Calacatta, Alabastro, Ardesia, Portoro mate, Portoro brillo, Emperador o Makalu.

Bistrot Tisch mit Basis aus Stahl lackiert titan, graphite oder schwarz gaufriert und Rahmen der Platte aus Metall lackiert titan, graphite oder schwarz gaufriert oder Brushed Bronze. Platte in Keramik Marmi in den Farben Calacatta, Alabastro, Ardesia, matt Portoro, glänzend Portoro, Emperador oder Makalu.

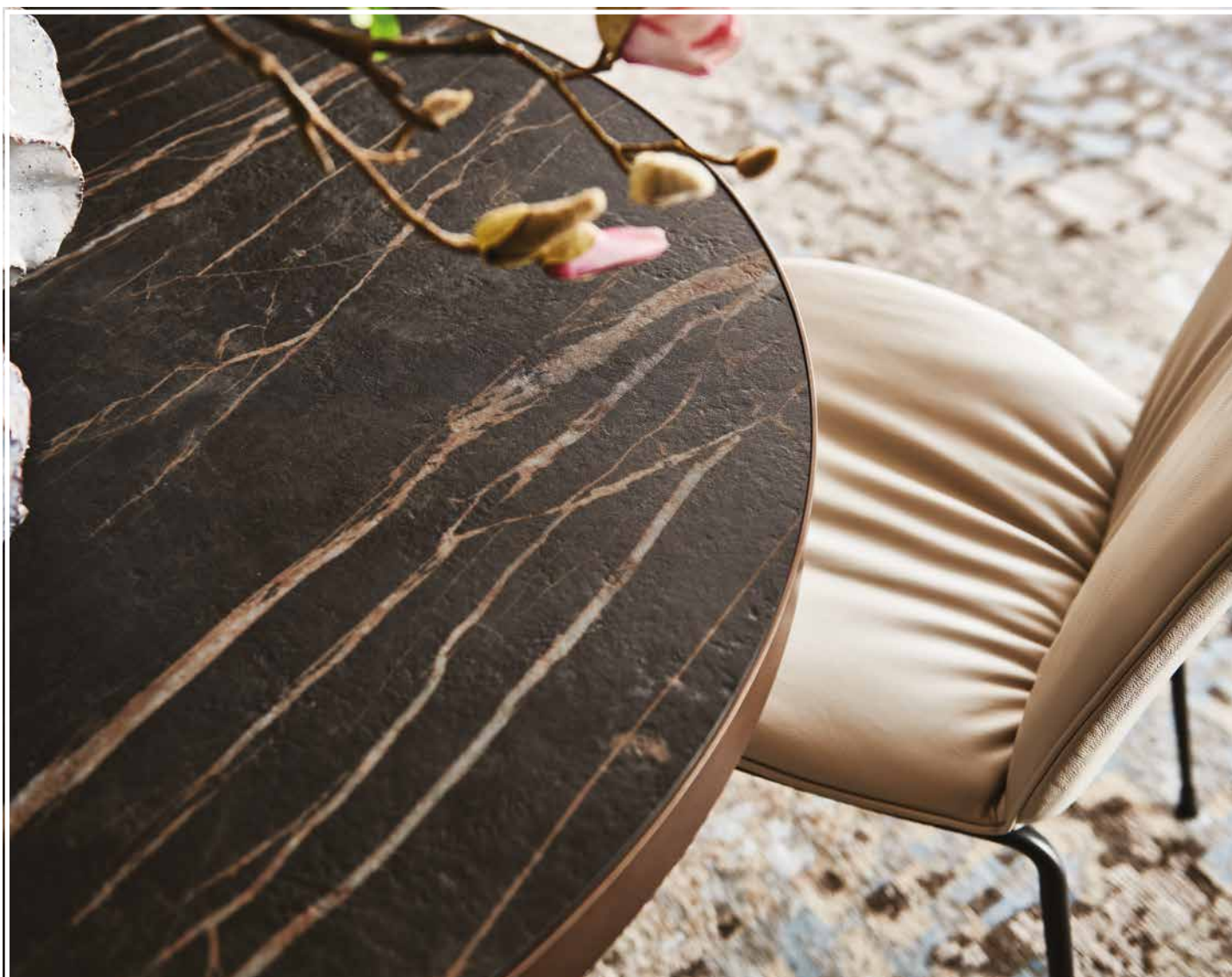
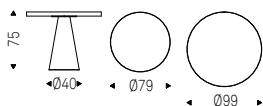







SATURNO KERAMIK BISTROT table with titanium base and top in matt Portoro ceramic and Brushed Bronze top frame
TINA chair with black steel frame and soft leather 948 Lino - PHOENIX lamp - NAUTILUS bookcase in titanium - RADJA rug

RIBOT Keramik Bistrot

Design **Giorgio Cattelan**

Tavolo bistrot con base in acciaio verniciato gofrato titanio, graphite o nero, e cornice del top in acciaio verniciato gofrato titanio, graphite o nero o Brushed Bronze. Piano in ceramica Marmi nei colori Calacatta, Alabastro, Ardesia, Portoro opaco, Portoro lucido, Emperador o Makalu.

Bistrot table with base in titanium, graphite or black embossed lacquered steel and top frame in titanium, graphite or black embossed lacquered steel or Brushed Bronze. Marmi Calacatta, Alabastro, Ardesia, matt Portoro, glossy Portoro, Emperador or Makalu ceramic top.

Table bistrot avec base en acier gaufré titane, graphite ou noir et bord du plateau en acier gaufré titane, graphite ou noir ou Brushed Bronze. Plateau en céramique Marmi dans les couleurs Calacatta, Alabastro, Ardesia, Portoro opaque, Portoro brillant, Emperador ou Makalu.

Mesa bistrot con base en acero barnizado gofrado titanio, graphite o negro y marco del sobre en acero barnizado gofrado titanio, graphite, negro o Brushed Bronze. Sobre en cerámica Marmi colores Calacatta, Alabastro, Ardesia, Portoro mate, Portoro brillo, Emperador o Makalu.

Bistrot Tisch mit Basis aus Stahl lackiert titan, graphite oder schwarz gaufriert und Rahmen der Platte aus Metall lackiert titan, graphite oder schwarz gaufriert oder Brushed Bronze. Platte in Keramik Marmi in den Farben Calacatta, Alabastro, Ardesia, matt Portoro, glänzend Portoro, Emperador oder Makalu.

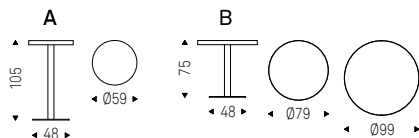









WESTIN CONSOLLE KERAMIK PREMIUM with black base and top in glossy Portoro ceramic and Brushed Bronze lower profile - GLENN mirror in bronze mirrored glass

**WESTIN Consolle
Keramik Premium**

Design G. Cattelan P. Cattelan

Consolle con base in acciaio verniciato gofrato titanio, bianco, graphite, mix o Brushed Bronze. Piano in ceramica Marmi nei colori Calacatta, Alabastro, Ardesia, Golden Calacatta opaco, Golden Calacatta lucido, Portoro opaco, Portoro lucido, Sahara Noir lucido, Emperador o Makalu con profilo inferiore arrotondato e verniciato nero o Brushed Bronze. Fissaggio a parete necessario.

Console with base in titanium, white, graphite or mix embossed lacquered steel or Brushed Bronze. Top in ceramic Marmi Calacatta, Alabastro, Ardesia, matt Golden Calacatta, glossy Golden Calacatta, matt Portoro, glossy Portoro, glossy Sahara Noir, Emperador or Makalu with black or Brushed Bronze lacquered and rounded lower profile. Wall anchorage is necessary.

Console avec base en acier gaufré, laqué titane, blanc, graphite, mix ou Brushed Bronze. Plateau en céramique Marmi dans les couleurs Calacatta, Alabastro, Ardesia, Golden Calacatta opaque, Golden Calacatta brillant, Portoro opaque, Portoro brillant, Sahara Noir brillant, Emperador ou Makalu avec profil inférieur arrondi laqué noir ou Brushed Bronze. Fixation au mur nécessaire.

Consola con base en acero barnizado gofrado titanio, blanco, graphite, mix o Brushed Bronze. Sobre en cerámica Marmi colores Calacatta, Alabastro, Ardesia, Golden Calacatta mate, Golden Calacatta brillo, Portoro mate, Portoro brillo, Sahara Noir brillo, Emperador o Makalu y perfil inferior redondeado barnizado negro o Brushed Bronze. Ajuste a la pared necesario.

Konsole mit Basis in Stahl lackiert titan, weiß, graphite gaufriert oder mix oder Brushed Bronze. Platte aus Keramik Marmi in den Farben Calacatta, Alabastro, Ardesia, matt Golden Calacatta, glänzend Golden Calacatta, glänzend Portoro, glänzend Portoro, glänzend Sahara Noir, Emperador oder Makalu mit schwarz oder Brushed Bronze lackierten abgerundeten Profil. Wandbefestigung ist notwendig.

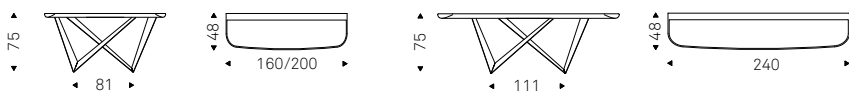







TERMINAL CONSOLLE KERAMIK PREMIUM with Brushed Bronze base and top in Makalu ceramic and Brushed Bronze lower profile - WISH mirror, with Brushed Bronze frame

TERMINAL Consolle
Keramik Premium
Design **Paolo Cattelan**

Consolle con base in acciaio verniciato gofrato titanio, graphite, nero o Brushed Bronze. Piano in ceramica Marmi nei colori Calacatta, Alabastro, Ardesia, Golden Calacatta opaco, Golden Calacatta lucido, Portoro opaco, Portoro lucido, Sahara Noir lucido, Emperador o Makalu con profilo inferiore arrotondato e verniciato nero o Brushed Bronze. Fissaggio a parete necessario.

Console with base in titanium, graphite or black embossed lacquered steel or Brushed Bronze. Top in ceramic Marmi Calacatta, Alabastro, Ardesia, matt Golden Calacatta, glossy Golden Calacatta, matt Portoro, glossy Portoro, glossy Sahara Noir, Emperador or Makalu with black or Brushed Bronze lacquered and rounded lower profile. Wall anchorage is necessary.

Console avec base en acier gaufré, laqué titane, graphite, noir ou Brushed Bronze. Plateau en céramique Marmi dans les couleurs Calacatta, Alabastro, Ardesia, Golden Calacatta opaque, Golden Calacatta brillant, Portoro opaque, Portoro brillant, Sahara Noir brillant, Emperador ou Makalu avec profil inférieur arrondi laqué noir ou Brushed Bronze. Fixation au mur nécessaire.

Consola con base en acero barnizado gofrado titanio, graphite, negro o Brushed Bronze. Sobre en cerámica Marmi colores Calacatta, Alabastro, Ardesia, Golden Calacatta mate, Golden Calacatta brillo, Portoro mate, Portoro brillo, Sahara Noir brillo, Emperador o Makalu y perfil inferior redondeado barnizado negro o Brushed Bronze. Ajuste a la pared necesario.

Konsole mit Basis in Stahl lackiert titan, graphite, schwarz gaufriert oder Brushed Bronze. Platte aus Keramik Marmi in den Farben Calacatta, Alabastro, Ardesia, matt Golden Calacatta, glänzend Golden Calacatta, matt Portoro, glänzend Portoro, glänzend Sahara Noir, Emperador oder Makalu mit schwarz oder Brushed Bronze lackierten abgerundeten Profil. Wandbefestigung ist notwendig.

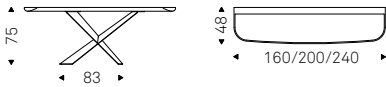





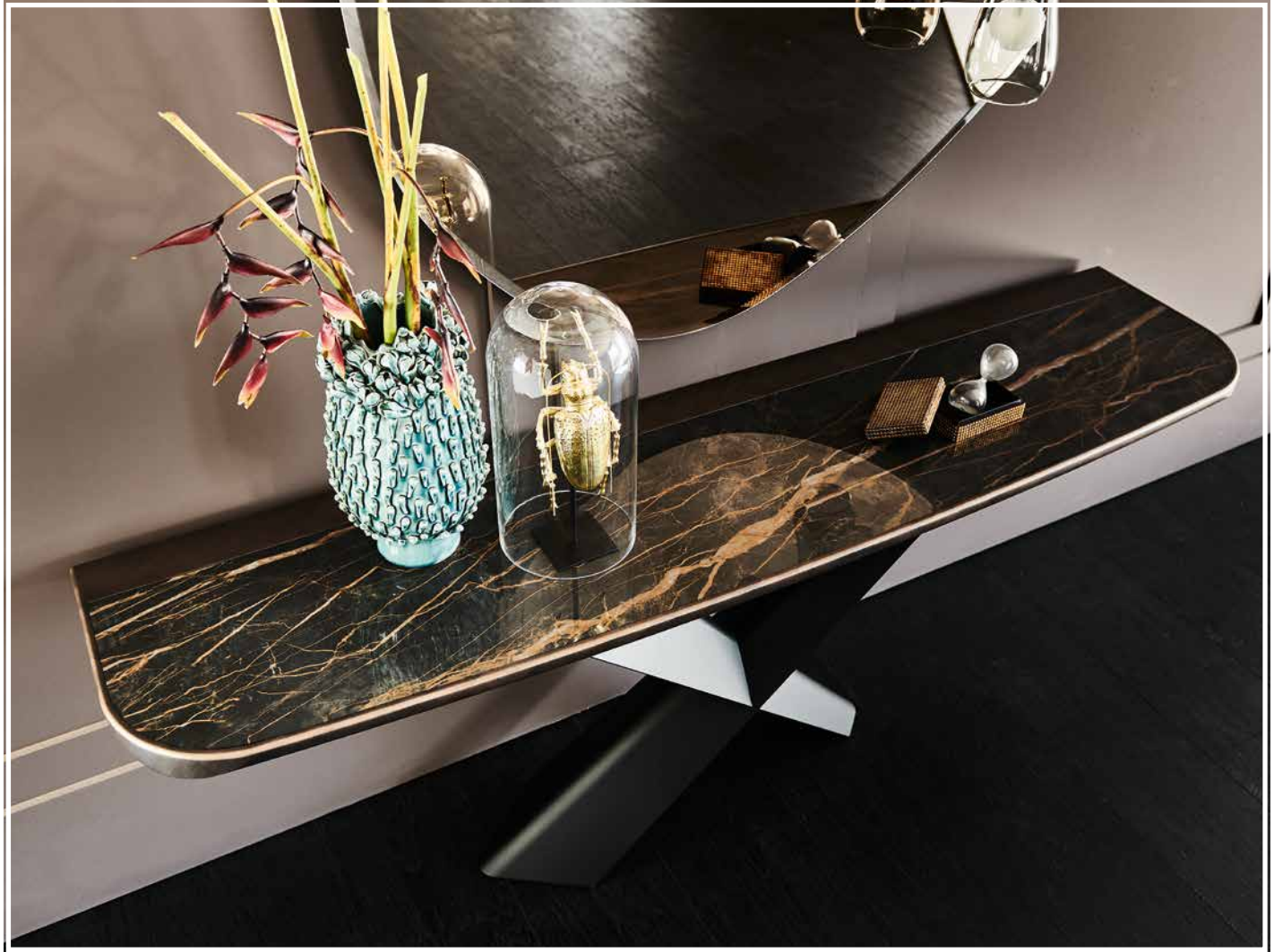



SKYLINE Console Wood-C

Design Brogliato & Traverso - Paolo Cattelan

Consolle con base in acciaio verniciato gofrato titanio, graphite o nero. Piano in noce Canaletto con profilo inferiore arrotondato e verniciato nero o Olmo tinto poro aperto nero opaco con profilo inferiore arrotondato verniciato Brushed Bronze. Fissaggio a parete necessario.

Console with base in titanium, graphite or black embossed lacquered steel. Top in Canaletto walnut with black lacquered and rounded lower profile or elm open pore matt black with Brushed Bronze lacquered and rounded lower profile. Wall anchorage is necessary.

Console avec base en acier gaufré titane, graphite ou noir. Plateau en noyer Canaletto avec profil inférieur arrondi laqué noire ou Orme laqué noir opaque pore ouvert avec profil inférieur arrondi laqué Brushed Bronze. Fixation au mur nécessaire.

Consola con base en acero barnizado gofrado titanio, graphite o negro. Sobre en nogal Canaletto y perfil inferior redondeado barnizado negro u Olmo barnizado negro mate a poro abierto y perfil inferior redondeado barnizado Brushed Bronze. Ajuste a la pared necesario.

Konsole mit Basis aus Stahl lackiert titan, graphite oder schwarz gaufriert. Platte aus Nussbaum Canaletto mit schwarz lackierten abgerundeten Profil oder Ulme offenporig lackiert schwarz matt mit Brushed Bronze lackierten abgerundeten Profil. Wandbefestigung ist notwendig.

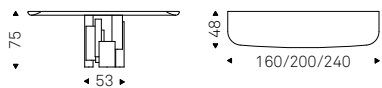







WOLF Keramik

Design Paolo Cattelan

Scrivania con base e cornice del top in acciaio verniciato gofrato titanio o nero, o con base in acciaio verniciato gofrato nero e cornice del top in Brushed Bronze. Piano in ceramica Marmi nei colori Calacatta, Alabastro, Ardesia, Golden Calacatta opaco, Golden Calacatta lucido, Portoro opaco, Portoro lucido, Sahara Noir lucido, Emperador o Makalu.

Desk with base and top frame in titanium or black embossed lacquered steel, or with base in black embossed lacquered steel and Brushed Bronze top frame. Top in ceramic Marmi Calacatta, Alabastro, Ardesia, matt Golden Calacatta, glossy Golden Calacatta, matt Portoro, glossy Portoro, glossy Sahara Noir, Emperador or Makalu.

Bureau avec base et bord du plateau en acier gaufré titane ou noir, ou avec base en acier gaufré noir et bord du plateau en Brushed Bronze. Plateau en céramique Marmi dans les couleurs Calacatta, Alabastro, Ardesia, Golden Calacatta opaque, Golden Calacatta brillante, Portoro opaque, Portoro brillant, Sahara Noir brillant, Emperador ou Makalu.

Escritorio con base y marco del sobre en acero barnizado gofrado titanio o negro, o con base en acero barnizado gofrado negro y marco del sobre en Brushed Bronze. Sobre en cerámica Marmi colores Calacatta, Alabastro, Ardesia, Golden Calacatta mate, Golden Calacatta brillo, Portoro mate, Portoro brillo, Sahara Noir brillo, Emperador o Makalu.

Schreibtisch mit Basis und Rahmen der Platte aus Stahl lackiert titan oder schwarz gaufriert oder mit Basis in Stahl lackiert schwarz gaufriert und Rahmen der Platte in Brushed Bronze. Platte aus Keramik Marmi in den Farben Calacatta, Alabastro, Ardesia, matt Golden Calacatta, glänzend Golden Calacatta, matt Portoro, glänzend Portoro, glänzend Sahara Noir, Emperador oder Makalu.

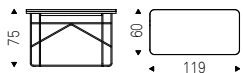



WOLF KERAMIK desk with black base, Brushed Bronze top frame and matt Portoro ceramic top - WENDY chair with black frame and soft leather 950 Tortora
NAUTILUS bookcase in titanium - CHELSEA sideboard in titanium







GINEVRA**Design Archirivolto**

Sedia con struttura in faggio naturale, tinto noce Canaletto, wenghè, bianco o nero opaco. Rivestimento in tessuto, synthetic nubuck, micro nubuck, ecopelle o pelle come da campionario. Non sfoderabile.

Chair with frame in natural beech, Canaletto walnut, wenghè, matt white or black stained beech. Cover in fabric, synthetic nubuck, micro nubuck, soft leather or synthetic leather as per sample card. The cover is not removable.

Chaise avec structure en hêtre naturel, teinté noyer Canaletto, wenghè, ou laqué blanc ou noir opaque. Revêtement en tissu, synthetic nubuck, micro nubuck, cuir mince ou simili cuir selon échantillons. Le revêtement n'est pas déhoussable.

Silla con estructura en haya natural, teñida nogal Canaletto, wenghè, blanco o negro mate. Revestimiento en tejido, synthetic nubuck, micro nubuck, ecopiel o piel según muestrario. El tapizado no es desenfundable.

Stuhl mit Struktur in Buche natur, gebeizt Nussbaum Canaletto, wenghè, matt weiß oder schwarz. Bezug in Stoff, synthetic nubuck, micro nubuck, Kunstleder oder Softleder laut Musterkarte. Nicht abziehbar.

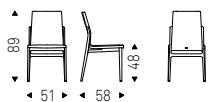





GINEVRA chair with black stained beech frame and soft leather 951 Castoro
SKORPIO KERAMIK table with black base and Makatu ceramic top



FLAMINGO**Design Paolo Cattelan**

Sedia con base a 4 razze girevole in nylon nei colori graphite, bianco o nero, o con base a 4 razze girevole in alluminio verniciato gofrato titanio, graphite, bianco o nero. Rivestimento in tessuto, synthetic nubuck, micro nubuck, ecopelle o pelle come da campionario. Non sfoderabile.

Swiveling chair with 4 spokes base in graphite, white or black nylon, or with 4 spokes base in titanium, graphite, white or black embossed lacquered aluminium. Cover in fabric, synthetic nubuck, micro nubuck, synthetic leather or soft leather as per sample card. The cover is not removable.

Chaise avec base à 4 rojons pivotante en nylon dans les couleurs graphite, blanc ou noir, ou base à 4 rayons pivotante en aluminium gaufré titane, graphite, blanc ou noir. Assise et dossier revêtus en tissu, synthetic nubuck, micro nubuck, simili cuir ou cuir mince selon échantillons. Le revêtement n'est pas déhoussable.

Silla con base giratoria de 4 radios en nylon en los colores graphite, blanco o negro, o base giratoria de 4 radios en aluminio barnizado gofrado titanio, graphite, blanco o negro. Revestimiento en tejido, synthetic nubuck, micro nubuck, ecopiel o piel según muestrario. Tapizado no desenfundable.

Stuhl mit 4-Sterne-Drehbasis aus Nylon in den Farben graphit, weiß oder schwarz oder mit 4-Sterne-Drehbasis aus Aluminium lackiert titan, graphite, weiß oder schwarz gaufriert. Sitzbezug in Stoff, synthetic Nubuck, micro Nubuck, Kunstleder oder Softleder laut Musterkarte. Nicht abziehbar.

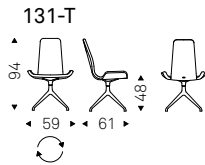
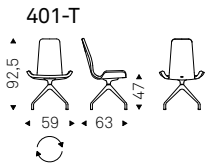

401 T



131 T





FLAMINGO chair with black frame and soft leather 951 Castoro - MUMBAI rug - CHELSEA sideboard in titanium

FLAMINGO Cantilever

Design Paolo Cattelan

Sedia cantilever con struttura in acciaio verniciato gofrato titanio, graphite, bianco o nero. Rivestimento in tessuto, synthetic nubuck, micro nubuck, ecopelle o pelle come da campionario. Non sfoderabile.

Chair with cantilever frame in titanium, graphite, white or black embossed lacquered steel. Upholstered seat in fabric, synthetic nubuck, micro nubuck, synthetic leather or soft leather as per sample card. The cover is not removable.

Chaise cantilever avec structure en acier laqué gaufré titane, graphite, blanc ou noir. Revêtement en tissu, synthetic nubuck, micro nubuck, simili cuir ou cuir mince selon échantillons. Le revêtement n'est pas déhoussable.

Silla con estructura en acero barnizado gofrado titanio, graphite, blanco o negro. Revestimiento embutido tapizado en tejido, synthetic nubuck, micro nubuck, ecopiel o piel según muestrario. El tapizado no es desenfundable.

Freischwinger-Stuhl mit Gestell aus Stahl lackiert titan, graphite, weiß oder schwarz gaufriert. Gepolsterte Sitz mit Stoff, synthetic nubuck, micro nubuck, Kunstleder oder Softlederbezug laut Musterkarte. Nicht abziehbar.

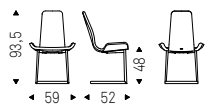

FLAMINGO CANTILEVER chair with titanium frame and soft leather 951 Castoro - MUMBAI rug





BELINDA B**Design Paolo Cattelan**

Sedia con o senza braccioli con struttura in frassino naturale, frassino tinto noce Canaletto, frassino tinto rovere bruciato, frassino laccato poro aperto bianco o nero opaco. Seduta e schienale rivestiti in tessuto, synthetic nubuck, micro nubuck, ecopelle o pelle come da campionario. Non sfoderabile.

Chair with or without arms with frame in natural ashwood, Canaletto walnut stained ashwood, burned oak stained ashwood or open pore matt white or black ashwood. Seat and back upholstered in fabric, synthetic nubuck, micro nubuck, synthetic leather or soft leather as per sample card. The cover is not removable.

Chaise avec ou sans accoudoirs avec structure en frêne naturel, frêne teinté noyer Canaletto, frêne teinté rovere brulé ou laqué blanc ou noir opaque pore ouvert. Assise et dossier revêtus en tissu, synthetic nubuck, micro nubuck, simili cuir ou cuir mince selon échantillons. Le revêtement n'est pas déhoussable.

Silla con o sin brazos con estructura en fresno natural, fresno barnizado nogal Canaletto, fresno barnizado roble ahumado, fresno barnizado blanco o negro mate a poro abierto. Asiento y respaldo tapizados en tejido, synthetic nubuck, micro nubuck, ecopiel o piel según muestrario. El tapizado no es desenfundable.

Stuhl mit oder ohne Armlehnen mit Struktur in Esche gebeizt Esche Natur, Nussbaum Canaletto, "verbrannte Eiche", oder offenporig lackiert in den Farben matt weiß oder matt schwarz. Sitz und Rücken mit Stoff, synthetic nubuck, micro nubuck, Kunstleder oder Softlederbezug, laut Musterkarte. Nicht abziehbar.

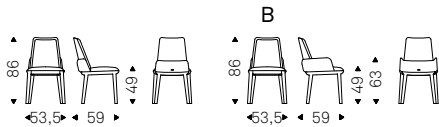

BELINDA chair with burned oak stained ashwood frame and soft leather 951 Castoro

TINA

Design Archirivolto

Sedia con struttura in acciaio verniciato gofrato titanio, graphite, bianco o nero. Rivestimento in tessuto, synthetic nubuck, micro nubuck, ecopelle o pelle come da campionario. Non sfoderabile.

Chair with frame in titanium, graphite, white or black embossed lacquered steel. Cover in fabric, synthetic nubuck, micro nubuck, soft leather or synthetic leather as per sample card. The cover is not removable.

Chaise avec structure en acier laqué gaufré titane, graphite, blanc ou noir. Revêtement en tissu, synthetic nubuck, micro nubuck, cuir mince ou simili cuir selon échantillons. Le revêtement n'est pas déhoussable.

Silla con estructura en acero barnizado gofrado titanio, graphite, blanco o negro. Revestimiento en tejido, synthetic nubuck, micro nubuck, piel o ecopiel según muestrario. El tapizado no es desenfundable.

Stuhl mit Gestell aus Stahl lackiert titan, graphite, weiß oder schwarz gaufriert. Bezug aus Stoff, synthetic nubuck, micro nubuck, Softleder oder Kunstleder laut Musterkarte. Nicht abziehbar.

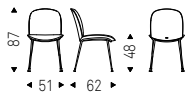

TINA chair with black steel frame and soft leather 948 Lino







TINA chair with black steel frame and fabric B237

KELLY Cantilever

Design Archirivolto

Sedia cantilever con struttura in acciaio verniciato gofrato titanio, graphite, bianco o nero. Rivestimento in tessuto, synthetic nubuck, micro nubuck, ecopelle o pelle come da campionario. Non sfoderabile.

Chair with cantilever frame in titanium, graphite, white or black embossed lacquered steel. Upholstered seat in fabric, synthetic nubuck, micro nubuck, synthetic leather or soft leather as per sample card. The cover is not removable.

Chaise cantilever avec structure en acier laqué gaufré titane, graphite, blanc ou noir. Revêtement en tissu, synthetic nubuck, micro nubuck, simili cuir ou cuir mince selon échantillons. Le revêtement n'est pas déhoussable.

Silla con estructura en acero barnizado gofrado titanio, graphite, blanco o negro. Revestimiento embutido tapizado en tejido, synthetic nubuck, micro nubuck, ecopiel o piel según muestrario. El tapizado no es desenfundable.

Freischwinger-Stuhl mit Gestell aus Stahl lackiert titan, graphite, weiß oder schwarz gaufriert. Gepolsterte Sitz mit Stoff, synthetic nubuck, micro nubuck, Kunstleder oder Softlederbezug laut Musterkarte. Nicht abziehbar.

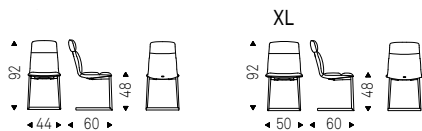

KELLY CANTILEVER XL chair with black frame and soft leather 973 Nero







WENDY

Design Paolo Cattelan

Sedia girevole con base a 4 razze in alluminio verniciato gofrato titanio, graphite, bianco o nero, rivestita in tessuto, ecopelle, synthetic nubuck, micro nubuck o pelle come da campionario. Non sfoderabile.

Swiveling chair with 4 spokes base in titanium, graphite, white or black embossed lacquered aluminium, covered in fabric, synthetic leather, synthetic nubuck, micro nubuck or soft leather as per sample card. The cover is not removable.

Chaise pivotante avec base à 4 rayons en aluminium gaufré titane, graphite, blanc ou noir, revêtue en tissu, simili cuir, synthetic nubuck, micro nubuck ou cuir mince selon échantillons. Le revêtement n'est pas déhoussable.

Silla giratoria con base con 4 radios en aluminio barnizado gofrado titanio, graphite, blanco o negro, revestida en tejido, ecopiel, synthetic nubuck, micro nubuck o piel según muestrario. El tapizado no es desenfundable.

Drehstuhl mit 4-Sterne-Basis aus Aluminium lackiert titan, graphite, weiß oder schwarz gaufriert, mit Bezug aus Stoff, Kunstleder, synthetic nubuck, micro nubuck oder Softleder laut Musterkarte. Nicht abziehbar.

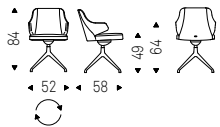

WENDY chair with black frame and soft leather 973 Nero



WENDY chair with black frame and soft leather 950 Tortora - SKORPIO KERAMIK table with black base and Makalu ceramic top

DUMBO Wood

Design Archirivolto

Sedia in frassino tinto noce Canaletto, frassino tinto rovere bruciato, frassino laccato poro aperto bianco o nero opaco.

Chair in Canaletto walnut stained ashwood, burned oak stained ashwood or open pore matt white or black ashwood.

Chaise en frêne teinté noyer Canaletto, rouvre brulé ou laqué blanc ou noir opaque pore ouvert.

Silla en fresno barnizado nogal Canaletto, roble ahumado, fresno barnizado blanco o negro mate a poro abierto.

Stuhl aus Esche gebeizt Nussbaum Canaletto, "verbrannte Eiche", oder offenporig lackiert in den Farben weiß oder schwarz matt.

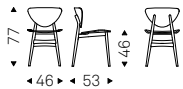

DUMBO WOOD chair in black ashwood frame



ISABEL Sgabello ML

Design **Paolo Cattelan**

Sgabello con struttura in acciaio cromo nero, verniciato opaco bianco, graphite o gofrato titanio. Cuscini imbottiti e rivestimento in tessuto, synthetic nubuck, micro nubuck, ecopelle o pelle come da campionario. Il rivestimento non è sfoderabile.

Stool with steel structure in black chrome, white, graphite or titanium embossed lacquered steel. Cushions and cover in fabric, synthetic nubuck, micro nubuck, synthetic leather or soft leather as per sample card. The cover is not removable.

Tabouret avec structure en acier chromé noir ou laqué blanc, graphite opaque ou gaufré titane. Coussins et revêtement en tissu, synthetic nubuck, micro nubuck, simili cuir ou cuir mince selon échantillons. Le revêtement n'est pas déhoussable.

Taburete con estructura en acero cromo negro, barnizado blanco, graphite mate o gofrado titanio. Cojines tapizados y revestimiento en tejido, synthetic nubuck, micro nubuck, ecopiel o piel según muestrario. El tapizado no es desenfundable.

Barhocker mit schwarz chrom, weiß, graphite oder titan lackiertem Stahlgestell. Gepolsterte Kissen und Bezug aus Kunstleder, Stoff, synthetic Nubuck, micro Nubuck oder Softleder laut Musterkarte. Nicht abziehbar.

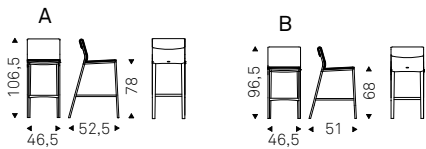



CARNABY

Design R Industrial Design

Madia contenitore a due o tre ante in legno laccato moka lucido, bianco lucido, bianco opaco, graphite opaco o titanio. Ante in cristallo bombato specchiato bronzo o fumé con profili in alluminio verniciato titanio goffrato. Piedini in acciaio inox lucido, verniciati bianco o graphite opaco. Ripiani interni in cristallo trasparente. Optional: cassetto interno posizionabile su ognuna delle ante. Optional: top in cristallo specchiato in tinta con le ante.

Sideboard 2 or 3 doors lacquered glossy moka, glossy white, matt white, matt graphite or titanium. Doors in smoked grey or bronze convex mirrored glass with embossed titanium aluminum profiles. Polished stainless steel feet, matt white or graphite varnished. Internal clear glass shelves. Optional: internal drawer in each door. Optional: mirrored glass top matching the doors colour.

Bahut 2 ou 3 portes en bois laqué moka brillant, blanc brillant, blanc opaque, graphite opaque ou titane. Portes en verre convexe miroité fumé ou miroité bronze avec profilés en aluminium gaufré titane. Pieds en acier inox brillant, laqués blanc ou graphite opaque. Etagères en verre clair. Optionnel: tiroir interne positionnable sur chacune des portes. Optionnel: plateau en verre miroité de la même couleur des portes.

Aparador de 2 o 3 puertas en madera lacada moka brillo, blanco brillo, blanco mate, graphite mate o titanio. Puertas en cristal convexo reflejado fumé o reflejado bronzo y perfil en aluminio gofrado titanio. Patas en acero inox brillo, barnizado blanco o graphite mate. Estantes interiores en cristal transparente. Opcional: el cajón interior se puede posicionar en cada de las puertas. Opcional: sobre en cristal reflejado en el mismo color de las puertas.

Anrichte mit zwei oder drei Türen aus Holz glänzend lackiert moka, weiß, weiß matt, graphit matt oder titan. Türen aus fumé oder bronze verspiegeltem Konvex Glas mit titan gaufriert aluminium Rahmen. Füße aus glänzendem Edelstahl, oder matt weiß oder graphite lackiert. Innenböden aus Klarglas. Optional: Innenschublade hinter jeder Tür positionierbar. Optional: verspiegelte Glasplatte und Türen sind gleichfarbig.

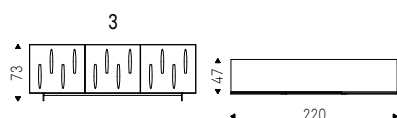
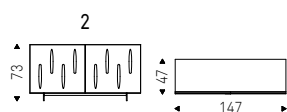

CARNABY sideboard matt graphite with doors in bronze mirrored glass



CARNABY sideboard titanium with doors and top in smoked grey mirrored glass





CARNABY sideboard matt graphite with doors and top in smoked grey mirrored glass - REGAL mirror with mirrored frame



KAYAK sideboard in Brushed Bronze - EMERALD mirror in fumé glass - MAPOON rug

KAYAK**Design Andrea Lucatello**

Madia contenitore a due o tre ante in legno laccato bianco lucido, nero lucido, moka lucido, rosso lucido, graphite opaco, titanio o Brushed Bronze. Piedini in acciaio inox lucido, verniciati bianco o graphite opaco. Ripiani interni in cristallo trasparente. Optional: cassetto interno posizionabile su ognuna delle ante.

Sideboard 2 or 3 doors in polished lacquered glossy black, glossy white, glossy moka, glossy red, matt graphite, titanium or Brushed Bronze. Polished stainless steel feet, matt white or graphite varnished. Internal clear glass shelves. Optional: internal drawer in each door.

Bahut 2 ou 3 portes bois laqué blanc brillant, noir brillant, moka brillant, rouge brillant, graphite opaque, titane ou Brushed Bronze. Pieds en acier inox brillant, laqué blanc ou graphite opaque. Étagère en verre clair. Optionnel: tiroir interne positionnable sur chacune des portes.

Aparador de 2 o 3 puertas en madera lacada blanco brillo, negro brillo, moka brillo, rojo brillo, graphite mate, titanio o Brushed Bronze. Patas en acero inox brillo, barnizado blanco o graphite mate. Estantes interiores en cristal transparente. Opcional: el cajón interior se puede posicionar en cada de las puertas.

Anrichte mit zwei oder drei Türen in Holz glänzend lackiert in weiß, schwarz, moka, rot, matt lackiert in graphit, lackiert titan oder Brushed Bronze. Füße aus glänzendem Edelstahl, oder matt weiß oder graphit lackiert. Innenböden in Klarglas. Optional: Innenschublade hinter jeder Tür positionierbar.

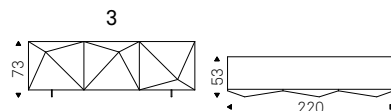
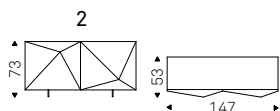





BOUTIQUE

Design Alberto Danese

Madia con struttura e piedi in acciaio verniciato goffrato nero, ante e fianchi in cristallo fumè con fasce in cristallo verniciato nero. Top e fondo in cristallo verniciato nero acidato, schienale interno in ecopelle o pelle trapuntata come da campionario. Ripiano interno in cristallo fumè. Illuminazione a led inclusa.

Sideboard with frame and feet in black embossed lacquered steel, doors and sides in fumè glass with stripes in black painted glass. Top and bottom in black painted frosted glass, internal back covered and quilted in soft leather or synthetic leather as per sample card. Internal shelf in fumè glass. LED light.

Bahut avec structure et pieds en acier gaufré noir, portes et côtés en verre fumé avec bandes en verre laqué noir. Plateau et fond en verre dépoli laqué noir, dos interne matelassé en simili cuir ou cuir mince selon échantillons. Étagère interne en verre fumé. Éclairage à led inclus.

Aparador con estructura y patas en acero barnizado gofrado negro, puertas y laterales en cristal fumè con bandas en cristal barnizado negro. Sobre y fondo en cristal barnizado negro translúcido, respaldo interior en ecopiel o piel acolchada según muestrario. Estante interior en cristal fumè. Iluminación led incluida. |

Anrichte mit Struktur und Füße in Stahl lackiert schwarz gaufriert, Türen und Seiten in Glas fumè mit Blende in Glas lackiert schwarz. Top und Boden in Glas lackiert schwarz geätzt. Innere Rückwand in Kunstleder oder Softleder gesteppt laut Musterkarte. Innenboden aus Glas fumè. LED-Beleuchtung enthalten.

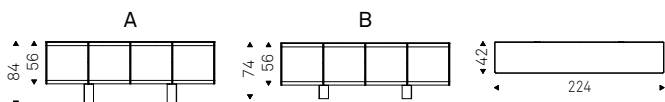



BOUTIQUE sideboard in ECP 26 Fango - WISH S mirror with Brushed Bronze frame - PLANETA lamp



BOUTIQUE sideboard in ECP 26 Fango - GLENN mirror in bronze mirrored glass - MELODY lamp









VOYAGER sideboard with doors in mirrored frosted bronze glass with black decorations - CIRCUIT lamp

VOYAGER**Design Lorenzo Remedi**

Madia a due o tre ante in legno laccato moka lucido, bianco lucido, bianco opaco, graphite opaco o titanio. Ante in cristallo specchiato bronzo acidato con decori in rilievo in nero lucido o ante in cristallo specchiato bronzo con decori in rilievo in colore oro. Profili in alluminio verniciato titanio goffrato. Piedini in acciaio inox lucido, verniciati bianco o graphite opaco. Ripiani interni in cristallo trasparente. Optional: cassetto interno posizionabile su ognuna delle ante. Optional: top in cristallo specchiato bronzo acidato.

Sideboard 2 or 3 doors in polished lacquered wood glossy moka, glossy white, matt white, matt graphite or titanium. Doors in mirrored frosted bronze glass with relief glossy black decorations or in mirrored bronze glass with relief golden decorations. Embossed titanium aluminium profiles. Feet in polished stainless steel, matt white or graphite varnished. Internal shelves in clear glass. Optional: internal drawer in each door. Optional: top in extra clear mirrored frosted bronze glass.

Bahut 2 ou 3 portes en bois laqué moka brillant, blanc brillant, blanc opaque, graphite opaque ou titane. Portes en verre dépoli miroité bronze avec décorations en relief noir brillant ou portes en verre miroité bronze avec décorations en relief or. Profilés en aluminium gaufré titane. Pieds en acier inox brillant, laqué blanc ou graphite opaque. Étagères en verre clair. Optionnel: tiroir interne positionnable sur chacune des portes. Optionnel: plateau en verre dépoli miroité bronze.

Aparador de dos o tres puertas con estructura de madera lacada moka brillo, blanco brillo, blanco mate, graphite mate o titanio. Puertas en cristal espejado bronce translúcido y decoraciones en relieve color negro brillo o puertas en cristal espejado bronce con decoraciones en relieve color oro. Perfiles en aluminio barnizado gofrado titanio. Patas en acero inox brillo, barnizadas blanco mate o graphite mate. Estantes interiores en cristal transparente. Opcional: el cajón interior se puede posicionar en cada de las puertas. Opcional: sobre en cristal espejado bronce translúcido.

Zwei- oder Dreitürige Anrichte in Holz lackiert moka glänzend, weiß glänzend, weiß matt, graphit matt oder titan. Türen in Glas verspiegelt bronze geätzt mit Reliefverzierung schwarz glänzend oder Türen in Glas verspiegelt bronze mit goldfarbiger Reliefverzierung. Profile in Aluminium lackiert titan gaufriert. Füße in Edelstahl glänzend, lackiert matt weiß oder matt graphite. Innenglasböden transparent. Optional: Innenschublade hinter jeder Tür positionierbar. Optional: Platte aus Glas lackiert bronze geätzt.

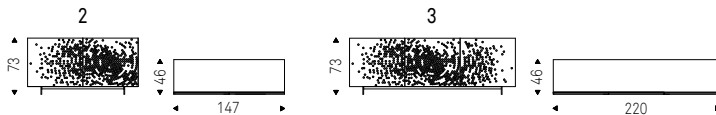





VOYAGER sideboard in graphite with doors in mirrored bronze glass with golden decorations and bronze glass top

CHELSEA

Design Alessio Bassan

Madia contenitore in legno laccato bianco, oyster o grey opaco o titanio. Top in cristallo extrachiaro verniciato bianco, oyster o grey o specchiato bronzo. Ripiani interni in cristallo trasparente. Versioni B con base in acciaio cromato o verniciato graphite o bianco opaco.

Sideboard in matt white lacquered, oyster, grey or titanium wood. Top in extra clear white, grey or oyster varnished glass or bronze mirrored glass. Internal clear glass shelves. B version with chrome steel base or matt graphite or white varnished.

Bahut en bois laqué blanc, oyster ou grey opaque ou titane. Top en verre extra-clair laqué blanc, grey ou oyster ou en verre miroité bronze. Etagère à l'intérieur en verre clair. Version B avec base en acier chromé, ou laqué graphite ou blanc opaque.

Aparador en madera lacado opaco blanco, oyster o grey o titanio. Sobre en cristal extraclaro pintado blanco, grey o oyster o en cristal reflejado bronzo. Estante interior en cristal transparente. Versión B con base en acero cromado o barnizado graphite o blanco mate.

Anrichte aus Holz weiß, oyster oder grey matt lackiert oder titan lackiert. Top extra hell Glas weiß, grey oder oyster lackiert oder bronze verspiegeltem Glas. Innenböden aus Klarglas. Version B mit Basis auf Edelstahl verchromt oder matt graphite oder weiß lackiert.

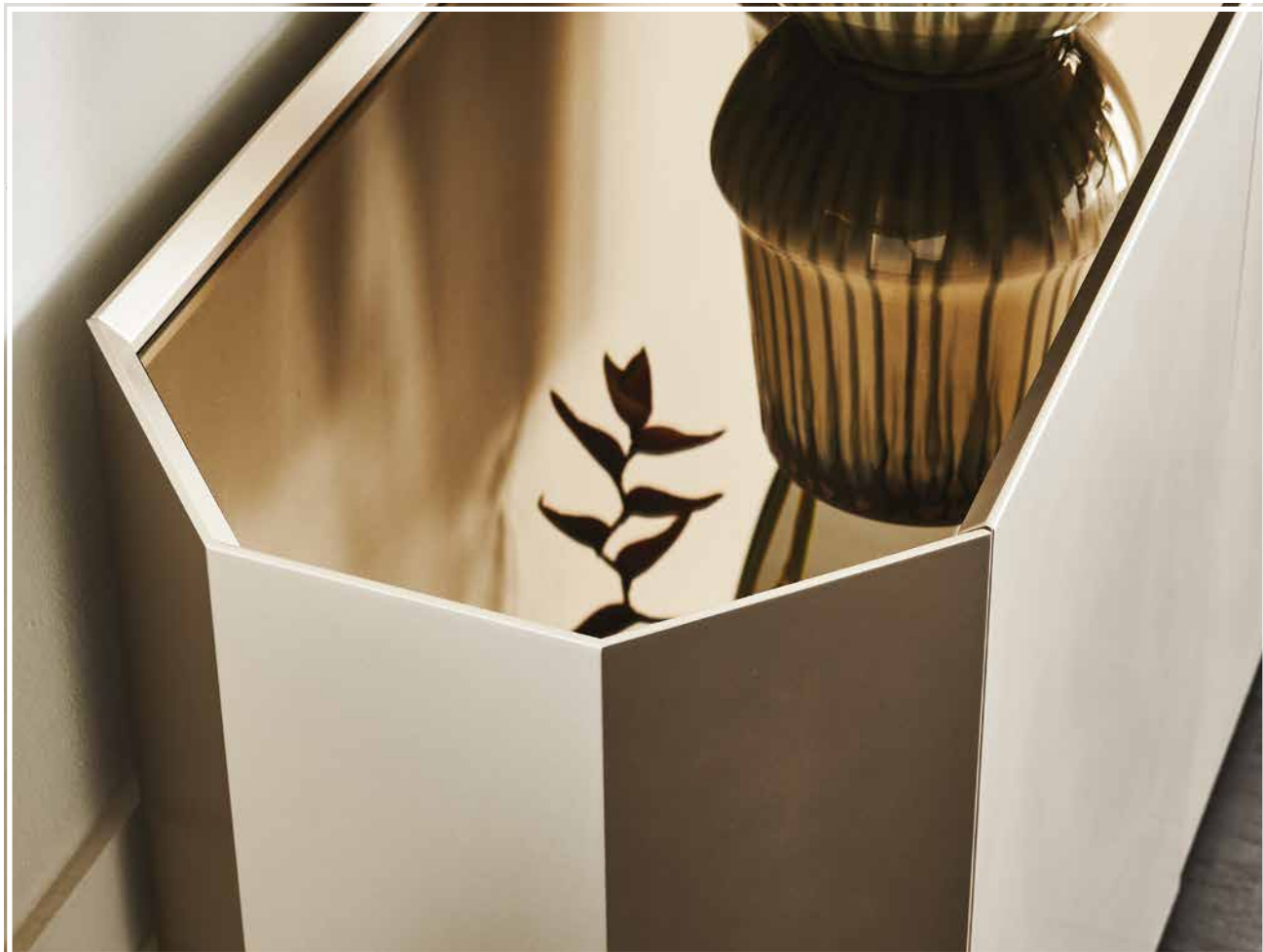
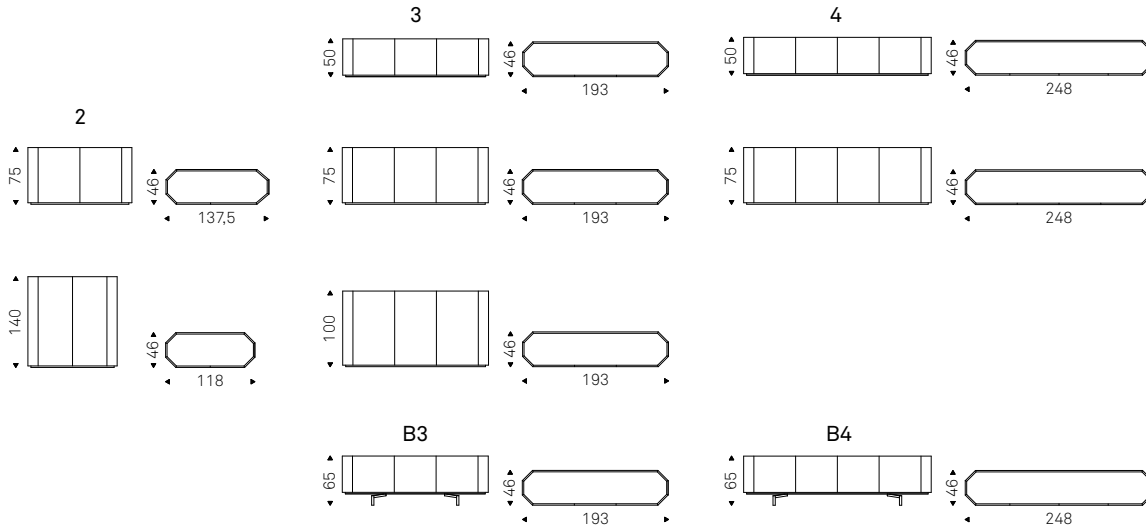





CHELSEA sideboard in titanium and bronze mirrored glass top - AFRICA mirror in smoked grey glass
SOHO KERAMIK PREMIUM table with titanium base and top in glossy Sahara Noir ceramic and Brushed Bronze lower profile
BELINDA chair with burned oak stained ashwood frame and soft leather 948 Lino - PHOENIX lamp - MUMBAI rug





ASTON TV cabinet with black base, left door in soft leather 956 Atlantico and right door in Brushed Bronze
STING BB - RADJA rug

ASTON TV**Design STC Studio**

Mobile porta tv in legno goffrato titanio o nero e base in acciaio goffrato titanio o nero. Anta sinistra rivestita in ecopelle o pelle trapuntata nei colori come da campionario con profili in alluminio verniciato titanio goffrato. Anta destra in noce Canaletto, rovere bruciato o Brushed Bronze con particolari in cromo nero. Ripiani interni in cristallo fumé.

TV cabinet in titanium or black embossed lacquered wood. Titanium or black embossed steel base. Left door covered and quilted in synthetic leather or soft leather as per sample card with titanium embossed aluminum profiles. Right door in Canaletto walnut, burned oak or Brushed Bronze with black chrome details. Internal fumé glass shelves.

Meuble porte-TV en bois gaufré titane ou noir et base en acier gaufré titane ou noir. Porte à gauche revêtue en simili cuir ou cuir mince matelassé selon échantillons profilé en aluminium gaufré titane. Porte à droite en noyer Canaletto, rovre brulé ou Brushed Bronze avec particuliers en chrome noir. Etagères en verre fumé.

Mueble para TV en madera gofrado titanio o negro con base en acero gofrado titanio o negro. Puerta izquierda revestida y acolchada en ecopiel o piel según muestrario y perfil en aluminio gofrado titanio. Puerta derecha en nogal Canaletto, roble ahumado o Brushed Bronze y detalles en cromo negro. Estantes interiores en cristal fumé.

TV Träger in Holz titan oder schwarz gaufriert mit Basis aus Stahl titan oder schwarz gaufriert. Linke Tür bezogen mit Kunstleder oder Softleder gesteppt laut Musterkarte und Aluminium Rahmen in titan gaufriert. Rechte Tür in Nussbaum Canaletto, "verbrannte Eiche" oder Brushed Bronze mit Einsätze in schwarz Chrome. Innenböden aus fumé Glas.

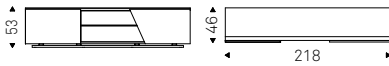

NAUTILUS

Design **Brogliato & Traverso**

Libreria componibile in acciaio gofrato titanio, graphite o nero. Fissaggio a parete necessario.

Modular bookcase in titanium, graphite or black embossed lacquered steel. Wall anchorage is necessary.

Bibliothèque modulaire en acier gaufré titane, graphite ou noir. Fixation au mur nécessaire.

Estantería modular en acero barnizado gofrado titanio, graphite o negro. Ajuste a la pared necesario.

Anbaubücherregal aus Edelstahl lackiert titan, graphite oder schwarz gaufriert. Wandbefestigung ist notwendig.

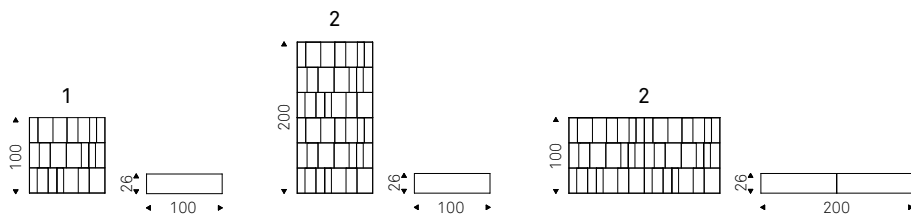













PIQUANT**Design Andrea Lucatello**

Libreria contenitore con struttura in MDF gofrato fine bianco o graphite. Ante scorrevoli in MDF gofrato fine bianco, graphite, grey, noce Canaletto, rovere naturale o Brushed Bronze. Portata massima 60 Kg distribuiti.

Bookshelves container with embossed white or graphite MDF frame, sliding doors in embossed white, graphite, grey, Canaletto walnut, natural oak or Brushed Bronze MDF. Max capacity: 60 kg spread load.

Bibliothèque/caisson de rangement. Structure mdf gaufré blanc ou graphite, portes coulissantes en mdf gaufré blanc, graphite, grey, noyer Canaletto, rovere naturel ou Brushed Bronze. Poids total admis 60 kg répartis.

Estantería con estructura en MDF lacado blanco o graphite gofrado fino, puertas correderas en MDF lacado blanco, graphite, grey gofrado fino, nogal Canaletto, roble natural o Brushed Bronze. Peso máximo 60 kg distribuidos.

Bücherregal mit Struktur aus MDF weiß oder graphite lackiert gaufriert. Schiebene Türen aus MDF lackiert gaufriert weiß, graphite, grey, Nussbaum Canaletto, Natur Eiche oder Brushed Bronze. Maximale Belastbarkeit (verteilt) 60 Kg.

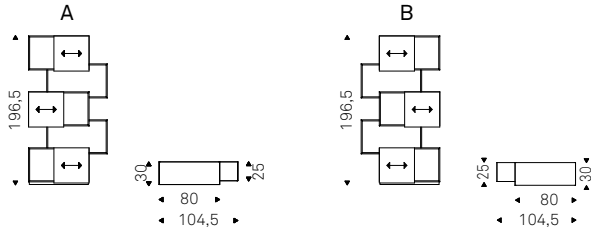

WALLY

Design Philip Jackson

Libreria componibile in MDF laccato titanio, bronzo, bianco, nero, graphite, oyster o ottanio gofrato fine.

Modular bookcase in titanium, bronze, white, black, graphite, oyster or ottanio lacquered embossed MDF.

Bibliothèque modulable en MDF gaufré titane, bronze, blanc, noir, graphite, oyster ou ottanio.

Estantería modular en MDF gofrado, lacado en titanio, bronce, blanco, negro, graphite, oyster u octano.

Anbaubücherregal aus MDF in titan, bronze, weiß, schwarz, graphite, oyster oder ottanio gaufriert.

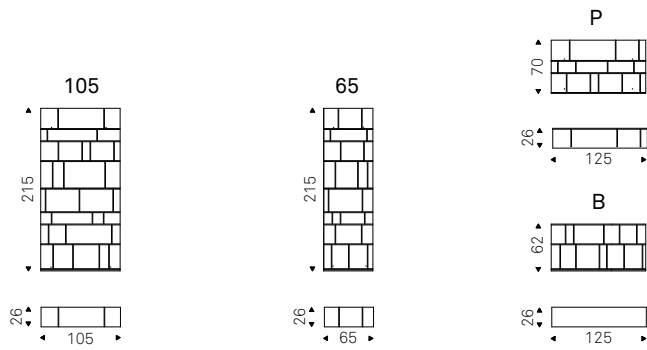





WISH S**Design Paolo Cattelan**

Specchio da parete in cristallo specchiato. Cornice in acciaio verniciato gofrato titanio o nero o Brushed Bronze.

Wall mirror. Frame in titanium or black embossed lacquered steel or Brushed Bronze.

Miroir mural avec cadre en acier gaufré titane ou noir ou Brushed Bronze. | Espejo de pared en cristal reflejado.

Marco en acero barnizado gofrado titanio o negro o Brushed Bronze.

Wandspiegel in Glas verspiegelt. Rahmen in Metall lackiert titan oder schwarz gaufriert oder Brushed Bronze.

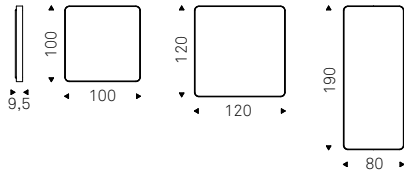

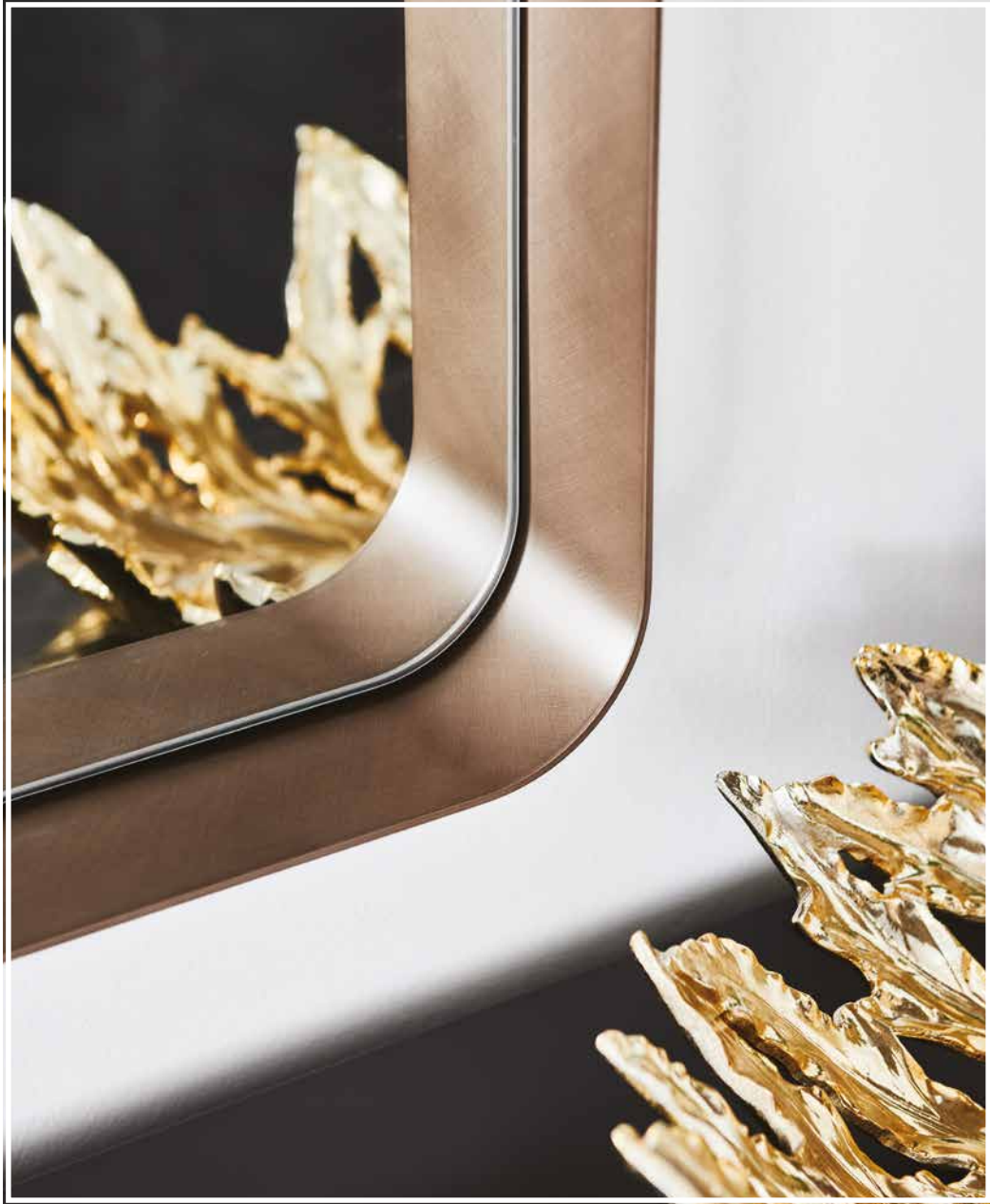



WISH Magnum

Design Paolo Cattelan

Specchio da parete in cristallo specchiato. Cornice in acciaio verniciato gofrato titanio o nero o Brushed Bronze.

Wall mirror. Frame in titanium or black embossed lacquered steel or Brushed Bronze.

Miroir mural avec cadre en acier gaufré titane ou noir ou Brushed Bronze.

Espejo de pared en cristal reflejado. Marco en acero barnizado gofrado titanio o negro o Brushed Bronze.

Wandspiegel in Glas verspiegelt. Rahmen in Metall lackiert titan oder schwarz gaufriert oder Brushed Bronze.

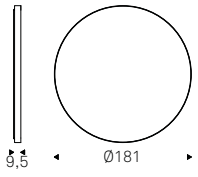



HAWAII Magnum

Design Studio Kronos

Specchio da parete tutto in cristallo specchiato, specchiato fumé o specchiato bronzo con bordi bisellati. Supporto a parete con possibilità di fissaggio in diverse posizioni.

Wall mirror in mirrored, smoked grey or bronze mirrored glass with bevelled edges. Wall bracket with fixing possibilities in different positions.

Miroir mural en verre miroité, miroité fumé ou miroité bronze avec bords biseautés. Support mural avec différentes ancrages.

Espejo de pared todo en cristal reflejado, reflejado fumé o reflejado bronzo y bordes biselados. Soporte de pared que permite un montaje en distintas posiciones.

Wandspiegel aus verspiegeltem, fumé oder Bronze verspiegeltem Glas mit facettierten Kanten. Wandhalterung mit Anschlussmöglichkeiten in verschiedenen Positionen.

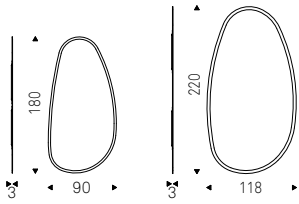



AFRICA

Design Paolo Cattelan

Specchio da parete tutto in cristallo specchiato fumé o specchiato bronzo con bordi bisellati.

Wall mirror in smoked grey or bronze mirrored glass with bevelled edges.

Miroir mural en verre miroité fumé ou miroité bronze avec bords biseautés.

Espejo de pared todo en cristal reflejado fumé o reflejado bronzo y bordes biselados.

Wandspiegel aus fumé oder Bronze verspiegeltem Glas mit facettierten Kanten.

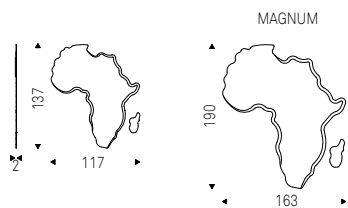



AFRICA mirror in smoked grey glass - CHELSEA sideboard in titanium

BILLY / BILLY Keramik

Design Studio Kronos

Tavolino con struttura in acciaio verniciato gofrato titanio o nero, o con base in Bronze e cornice del top in Brushed Bronze. Piano in cristallo specchiato bronzo o in ceramica Marmi nei colori Calacatta, Alabastro, Ardesia, Portoro opaco, Portoro lucido, Emperador o Makalu.

Coffee table with frame in embossed titanium or black lacquered steel, or with base in Bronze and Brushed Bronze top frame. Mirrored bronze glass top or marmi Calacatta, Alabastro, Ardesia, matt Portoro, glossy Portoro, Emperador or Makalu ceramic top.

Table basse avec structure en acier gaufré titane ou noir ou avec base en Bronze et bord du plateau en Brushed Bronze. Plateau en verre miroité bronze ou en céramique Marmi dans les couleurs Calacatta, Alabastro, Ardesia, Portoro opaque, Portoro brillant, Emperador ou Makalu.

Mesita con base en acero barnizado gofrado titanio o negro, o con patas en Bronze y marco del sobre en Brushed Bronze. Sobre en cristal reflejado bronzo o en cerámica Marmi colores Calacatta, Alabastro, Ardesia, Portoro mate, Portoro brillo, Emperador o Makalu.

Couchtisch mit Struktur aus lackiert titan oder schwarz gaufriert, oder mit Basis in Bronze und Rahmen der Platte in Brushed Bronze. Platte aus Glas verspiegelt Bronze oder in Keramik Marmi in den Farben Calacatta, Alabastro, Ardesia, matt Portoro, glänzend Portoro, Emperador oder Makalu.

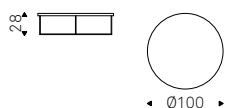
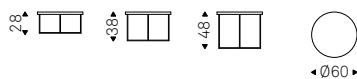

BILLY KERAMIK coffee table with black frame and matt Portoro ceramic top - BILLY coffee table with black frame and mirrored bronze glass top



BENNY Keramik

Design Studio Kronos

Tavolino con struttura in acciaio verniciato gofrato titanio o nero, o con base in Bronze e cornice del top in Brushed Bronze. Piano in ceramica Marmi nei colori Calacatta, Alabastro, Ardesia, Golden Calacatta opaco, Golden Calacatta lucido, Portoro opaco, Portoro lucido, Sahara Noir lucido, Emperador o Makalu.

Coffee table with frame in embossed titanium or black lacquered steel, or with base in Bronze and Brushed Bronze top frame. Marmi Calacatta, Alabastro, Ardesia, matt Golden Calacatta, glossy Golden Calacatta, matt Portoro, glossy Portoro, glossy Sahara Noir, Emperador or Makalu ceramic top.

Table basse avec structure en acier gaufré titane ou noir ou avec base en Bronze et bord du plateau en Brushed Bronze. Plateau en céramique Marmi dans les couleurs Calacatta, Alabastro, Ardesia, Golden Calacatta opaque, Golden Calacatta brillant, Portoro opaque, Portoro brillant, Sahara Noir brillant, Emperador ou Makalu.

Mesita con base en acero barnizado gofrado titanio o negro, o con patas en Bronze y marco del sobre en Brushed Bronze. Sobre en cerámica Marmi colores Calacatta, Alabastro, Ardesia, Golden Calacatta mate, Golden Calacatta brillo, Portoro mate, Portoro brillo, Sahara Noir brillo, Emperador o Makalu.

Couchtisch mit Struktur aus lackiert titan oder schwarz gaufriert, oder mit Basis in Bronze und Rahmen der Platte in Brushed Bronze. Platte in Keramik Marmi in den Farben Calacatta, Alabastro, Ardesia, matt Golden Calacatta, glänzend Golden Calacatta, matt Portoro, glänzend Portoro, glänzend Sahara Noir, Emperador oder Makalu.

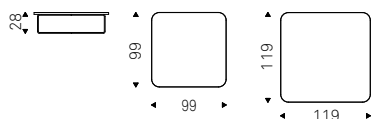
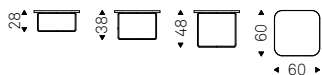
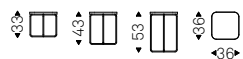

BENNY KERAMIK coffee table with black frame and matt Portoro ceramic top



BENNY KERAMIK coffee table with Brushed Bronze frame and Makalu ceramic top













IDEM coffee table with Canaletto walnut top - BENNY KERAMIK and BILLY KERAMIK coffee table with black frame and matt Portoro ceramic top - BILLY coffee table with black frame and mirrored bronze glass top - BENNY coffee table with Brushed Bronze frame and mirrored bronze glass top - BENNY KERAMIK coffee table with Brushed Bronze frame and matt Portoro ceramic top - STING BB - STING coffee table with black frame and matt Portoro ceramic top - TRESOR shelf with black frame and bronze mirrored glass - FISHERMAN lamp in black frame - BRANDY trolley

IDEM

Design Philip Jackson

Tavolino con struttura in metallo verniciato gofrato graphite e piano in noce Canaletto, rovere bruciato o rovere naturale con bordi irregolari in massello.

Coffee table with frame in graphite embossed lacquered steel and top in Canaletto walnut, burned oak or natural oak with irregular solid wood edges.

Table basse avec structure en acier gaufré graphite et plateau en noyer Canaletto, rovre brulé ou rovre naturel. Bords irréguliers en bois massif.

Mesita con estructura en acero barnizado gofrado graphite y sobre en nogal Canaletto, roble ahumado o roble natural con bordes irregulares en macizo.

Couchtisch mit Struktur aus Stahl lackiert graphite gaufriert und Platte aus Nussbaum Canaletto, "verbrannte Eiche" oder Eiche Natur mit massiven Kanten.

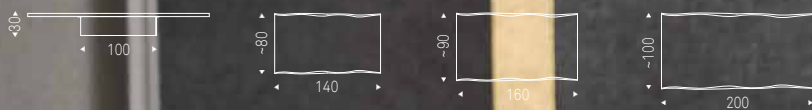





IDEM coffee table with Canaletto walnut top - BENNY KERAMIK and BILLY KERAMIK and STING coffee table with black frame and matt Portoro ceramic top - BILLY coffee table with black frame and mirrored bronze glass top - STING BB



AMERIGO

Design **Giorgio Cattelan**

Tavolino con base in metallo verniciato gofrato titanio e piano in metallo Brushed Brass.

Coffee table with base in titanium embossed lacquered steel and top in Brushed Brass lacquered steel.

Table basse avec base en acier gaufré titane et plateau en acier Brushed Brass.

Mesita con base en acero barnizado gofrado titanio y sobre en acero Brushed Brass.

Couchtisch mit Basis aus Stahl lackiert titan gaufriert und Platte in Stahl Brushed Brass.

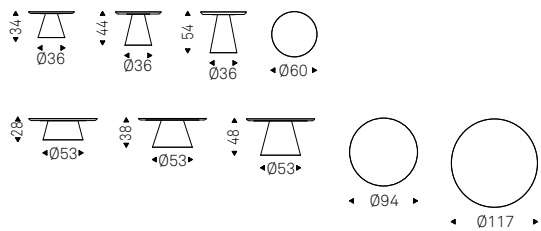





AMERIGO coffee table with titanium base and Brushed Brass top - CHENNAI rug - CHELSEA sideboard in titanium and bronze mirrored glass top - PLANETA lamp



STEP

Design Paolo Cattelan

Tavolino regolabile in altezza con base, gamba e piano in acciaio verniciato goffrato titanio o nero o in Brushed Brass. Stelo in acciaio cromo nero.

Adjustable coffee table with base, leg and top in titanium or black embossed lacquered steel or Brushed Brass. Stem in black chrome steel.

Table basse relevable avec base, pied et plateau en acier gaufré titane ou noir ou Brushed Brass. Tige en acier chromé noir.

Mesita regulable en altura con base, pata y sobre en acero barnizado gofrado titanio o negro o Brushed Brass. Tallo en acero cromado negro.

Höhenverstellbarer Couchtisch mit Basis, Fuß und Platte in Stahl lackiert titan oder schwarz gaufriert oder Brushed Brass. Ständer in Stahl schwarz Chrom.

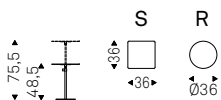



PEYOTE

Design **Piero De Longhi**

Tavolino in poliuretano rigido verniciato bianco, graphiteo titanioopaco. Piano in cristallo 5mm temperato extrachiaro verniciato bianco o graphite, specchiato bronzo o specchiato fumè.

Coffee table with matt white, graphite or titanium painted rigid polyurethane. Top in 5mm extra clear white or graphite painted tempered glass, bronze mirrored or fumé mirrored glass.

Table basse avec base en polyuréthane rigide laqué blanc, graphite ou titane opaque. Plateau en verre trempé 5mm extra-clair laqué blanc ou graphite, en verre miroité bronze ou miroité fumé.

Mesita en poliuretano rígido barnizado blanco, graphite mate o titanio. Sobre en cristal 5mm templado extraclaro barnizado blanco o graphite, reflejado bronce o reflejado fumé.

Couchtisch aus lackiertem Hartes Polyurethan matt weiß, matt graphite oder matt titan. Platte aus 5mm gehärtetem Glas extra weiß oder graphite lackiert, verspiegelt Bronze oder verspiegelt fumé.

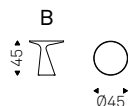
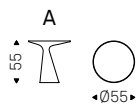





YAGO**Design Studio Kronos**

Tavolino fianco divano con base e piano in acciaio verniciato gofrato titanio o Brushed Bronze.

Side table with frame and top in titanium embossed lacquered steel or Brushed Bronze.

Table coté/canapé avec structure et plateau en acier gaufré titane ou Brushed Bronze.

Mesita lado sofá con estructura y sobre en acero barnizado gofrado titanio o Brushed Bronze.

Beistelltisch mit Struktur und Platte in Stahl lackiert titan gaufriert oder Brushed Bronze.



STING BB

Design **Paolo Cattelan**

Tavolino in acciaio Brushed Bronze.

Coffee table in Brushed Bronze steel.

Table basse en acier Brushed Bronze.

Mesita en acero Brushed Bronze.

Couchtisch aus Stahl Brushed Bronze.





ORLANDO

Design STC Studio

Tavolino alzabile con struttura in metallo verniciato gofrato titanio o nero e cristallo specchiato fumè. Piano in legno noce Canaletto, rovere bruciato o Olmo tinto poro aperto nero opaco.

Two-heights transformable coffee table with frame in titanium or black embossed lacquered steel and smoke-grey mirrored glass. Top in Canaletto walnut, burned oak or open pore matt black Elm.

Table basse relevable avec structure en acier gaufré titane ou noir et verre miroité fumé. Plateau en noyer Canaletto, rovere brulé ou Orme laqué noir opaque pore ouvert.

Mesita con sobre levantable con estructura en acero barnizado gofrado titanio o negro y cristal espejado fumè. Sobre de madera nogal Canaletto, roble ahumado u Olmo barnizado negro mate a poro abierto.

Höhenverstellbarer Couchtisch mit Struktur in Stahl lackiert titan oder schwarz gaufriert und Glas verspiegelt fumè. Platte in Nussbaum Canaletto, verbrannte Eiche oder Ulme offenporig lackiert mtt schwarz.







PLANETA**Design Studio Kronos**

Lampada da tavolo, sospensione, applique e piantana con struttura in ferro brunito e dettagli in ottone spazzolato. Paralumi in vetro soffiato bianco satinato. Lampadine incluse.

Table lamp, ceiling lamp, wall lamp and floor lamp with frame in burnished steel and details in brushed brass. Lampshades in blown satin white glass. Bulbs included.

Lampadaire, lampe de table, applique et lampe de sol avec structure en fer bruni et détails en laiton brossé. Diffuseur en verre soufflé blanc satiné. Ampoules comprises.

Lámpara de mesa, de techo, de pared y de tierra con estructura en hierro bruñido y detalles en latón cepillado. Pantallas en vidrio soplado blanco translúcido. Bombillas incluidas.

Tischlampe, Hängelampe, Wandleuchte und Stehlampe mit Struktur in brüniertes Eisen und Details in gebürstetem Messing. Lampenschirm in Blasenglas weiß satiniert. Leuchtmittel enthalten.

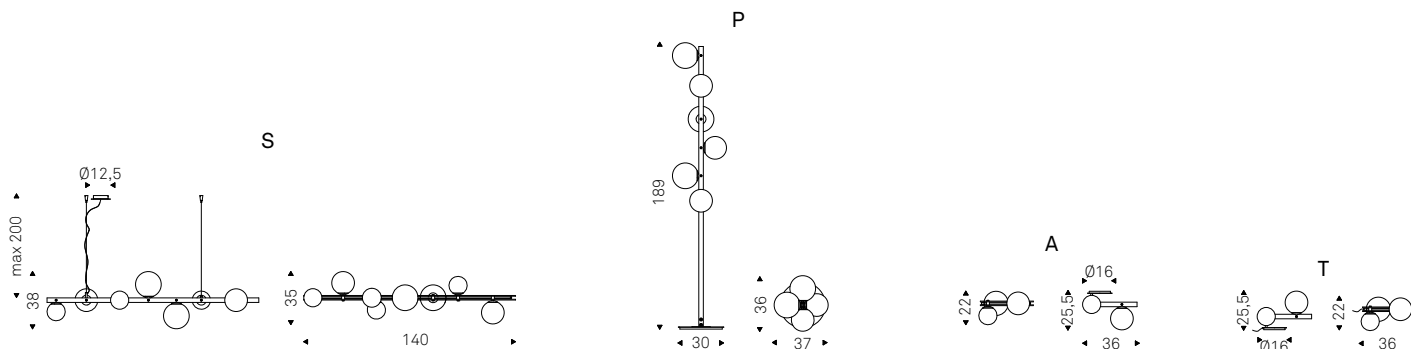









PHOENIX

Design STC Studio

Lampada a soffitto con struttura in acciaio Nichel satinato ed elementi in vetro lavorati a mano. Illuminazione a led.

Ceiling lamp with satin Nickel steel frame and handmade glass elements. Led lights.

Lampadaire avec structure en acier Nickel satiné et éléments en verre forgés à la main. Éclairage à led.

Lámpara de techo con estructura en acero Niquel satinado y elementos en vidrio hechos a mano. Iluminación led.

Hängelampe mit Stahlgestell in Nickel satiniert und Glaselementen handgearbeitet. LED Beleuchtung.

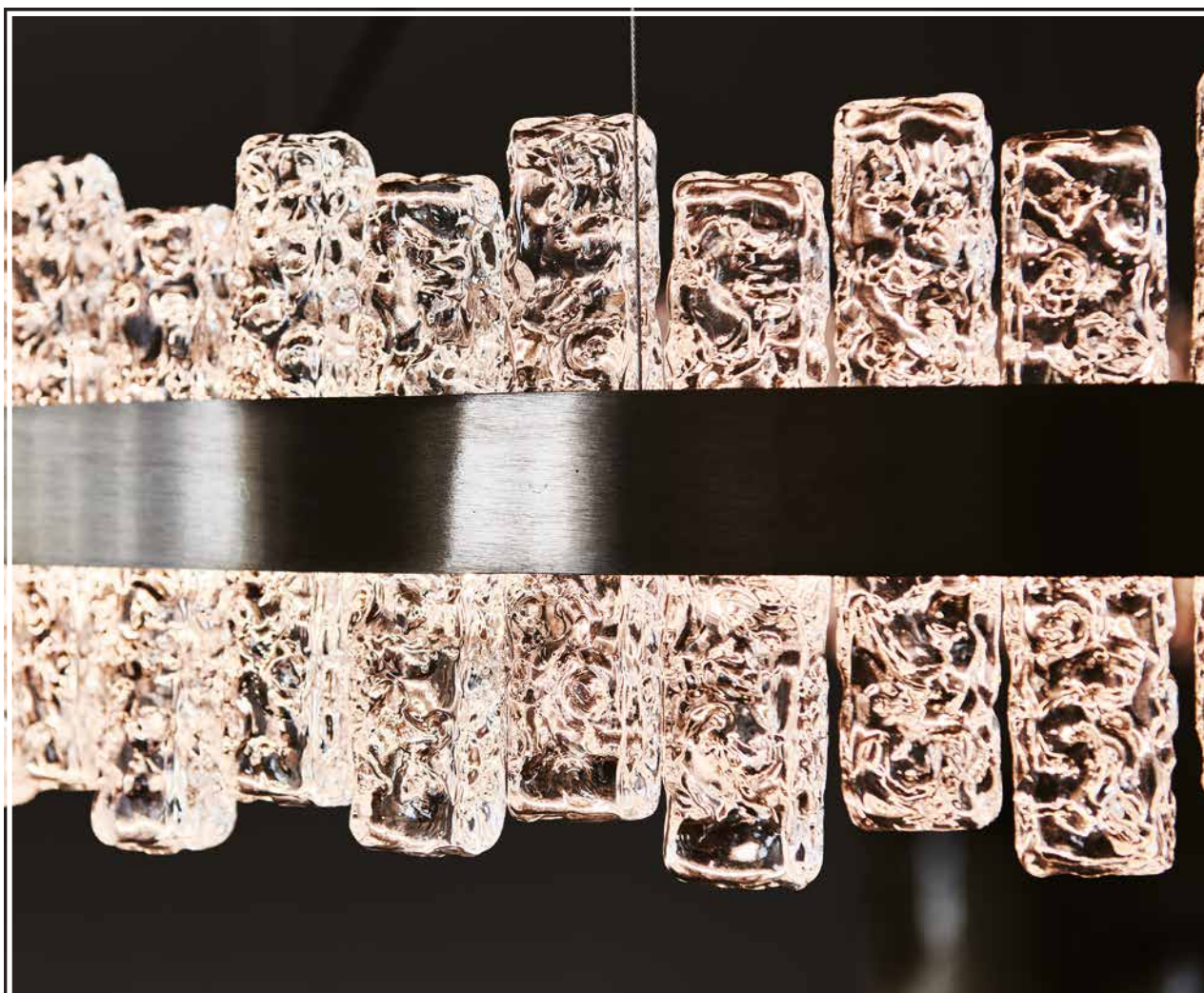
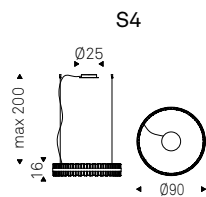
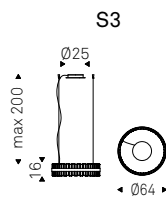
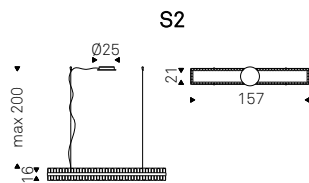
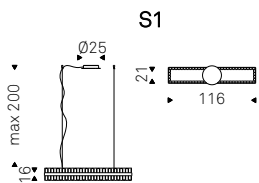



PHOENIX S4 lamp



BAMBOO**Design Studio Kronos**

Lampadario con struttura in ferro brunito e paralume in vetro soffiato fumè e vetro soffiato bianco satinato. Illuminazione integrata a led.

Ceiling lamp with frame in burnished steel, lampshade in blown fumé glass and blown satin white glass. Integrated LED light.

Lampadaire avec structure en fer bruni et diffuseur en verre soufflé fumé et verre soufflé blanc satiné. Éclairage à led intégré.

Lámpara de techo con estructura en hierro bruñido y pantalla en vidrio soplado fumè y vidrio soplado blanco translúcido. Iluminación led incluida.

Hängelampe mit Struktur in brüniertes Eisen und Lampenschirm in Blasenglas fumè und Blasenglas weiß satiniert. Integrierte LED-Beleuchtung.

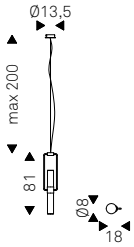

LORD

Design Archirivolto

Lampada a soffitto con struttura in metallo e particolari in cromo nero. Paralume rivestito in tessuto elasticizzato nero. Lampadina non inclusa.

Ceiling lamp with metal frame and black chrome details. Lampshade covered in black methacrylate. Bulb not included.

Lampadaire avec structure en métal et détails en chrome noir. Diffuseur revêtu en maille élastique noire. Ampoule non comprise.

Lámpara de techo con estructura de metal y detalles en cromo negro. Pantalla revestida con tejido elástico color negro. Bombilla no incluida.

Hängelampe mit Metallstruktur und Details in schwarz Chrom. Lampenschirm in schwarzem Stretch-Gewebe bezogen. Leuchtmittel nicht enthalten.

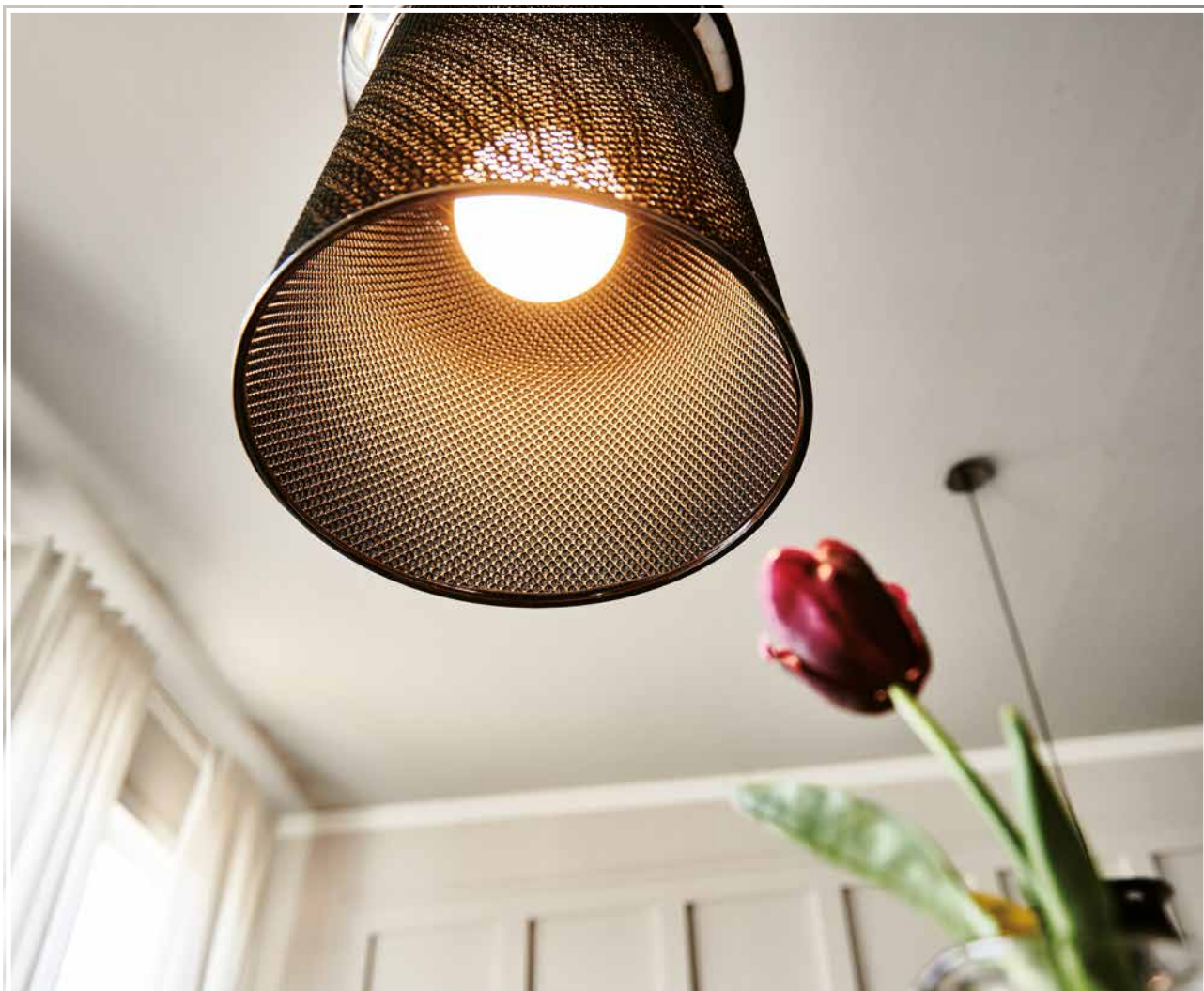
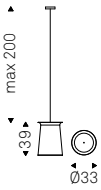



CIRCUIT

Design STC Studio

Lampadario e applique con struttura in acciaio verniciato gofrato titanio e nickel satinato. Paralume piccolo in vetro borosilicato trasparente e paralume grande in vetro borosilicato fumè. Illuminazione integrata a led.

Ceiling and wall lamp with frame in titanium embossed lacquered steel and satin Nickel. Small lampshade in borosilicate transparent glass, big lampshade in borosilicate fumè glass. Integrated LED light.

Lampadaire et applique avec structure en acier gaufré titane et nickel satiné. Petit diffuseur en verre borosilicate clair et grande diffuseur en verre borosilicate fumé. Éclairage à led intégré.

Lámpara de techo y de pared con estructura en acero barnizado gofrado titanio y níquel satinado. Pantalla pequeña en vidrio borosilicato transparente y pantalla grande en vidrio borosilicato fumè. Iluminación led incluida.

Hängelampe und Wanleuchte mit Struktur in Stahl lackiert titan gaufriert und Nickel satiniert. Kleiner Lampenschirm in transparentem Borosilikat-Glas und großer Lampenschirm in Borosilikat-Glas fumè. Integrierte LED-Beleuchtung.

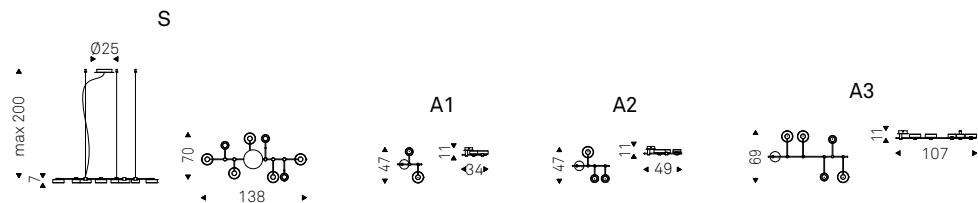









TWIN**Design STC Studio**

Piantana con struttura in acciaio verniciato gofrato graphite e acciaio ramato o cromo nero. Illuminazione a led.

Floor lamp with frame in graphite embossed lacquered steel and copper steel or black chrome. Led light.

Lampe de sol avec structure en acier gaufré graphite et acier cuivré ou chrome noir. Éclairage à led.

Lámpara de tierra con estructura en acero barnizado gofrado graphite y acero cobreado o cromo negro. Iluminación led.

Stehlampe mit Struktur in Stahl lackiert graphite gaufriert und Stahl kupferfarbig oder schwarz Chrom. LED-Beleuchtung.

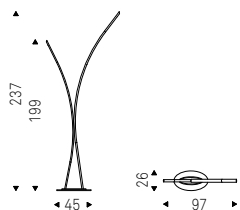

CHENNAI

Design STC Studio

Tappeto tessuto in cotone e
ciniglia a rilievo dall'aspetto
slavato e consumato.

Rug made in cotton and
chenille with relief and
with a faded and used
appearance.

Tapis en tissu de coton et
chenille, à l'aspect vieilli.

Alfombra en tejido de
algodón y felpa. Con aspecto
descolorido y gastado.

Teppich aus Baumwolle
und Chenille mit Relief-
Struktur. Mit verwaschem
und "Used-Look" Effekt.

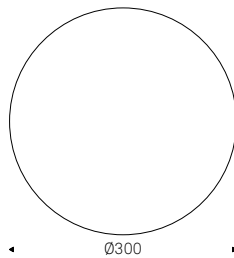
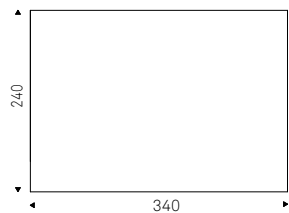
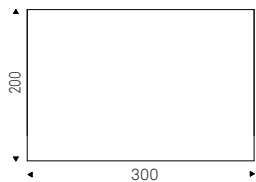



MUMBAI**Design STC Studio**

Tappeto tessuto in cotone e ciniglia a rilievo dall'aspetto slavato e consumato.

Rug made in cotton and chenille with relief and with a faded and used appearance.

Tapis en tissu de coton et chenille, à l'aspect vieilli.

Alfombra en tejido de algodón y felpa. Con aspecto descolorido y gastado.

Teppich aus Baumwolle und Chenille mit Relief-Struktur. Mit verwaschem und "Used-Look" Effekt.

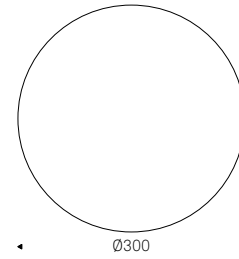
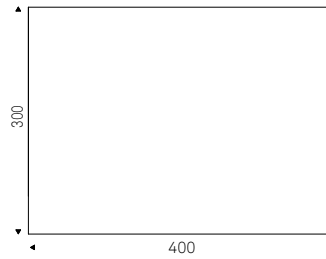
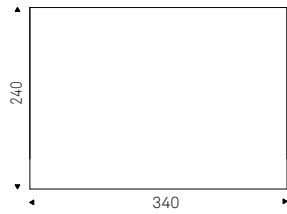
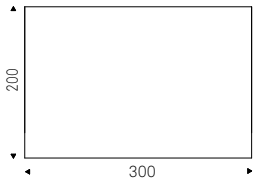

BIAGIO

Design Paolo Cattelan

Comodino reversibile con struttura verniciata gofrato titanio, graphite o bianco. Cassettiera in noce Canaletto o rovere bruciato.

Reversible nightstand with titanium, graphite or white embossed lacquered frame. Drawer unit in Canaletto walnut or burned oak.

Table de nuit reversible avec structure gaufré titane, graphite ou blanc. Tiroir en noyer Canaletto ou rouvre brûlé.

Mesa de noche reversible con estructura barnizada gofrado titanio, graphite o blanco. Cajonera en nogal Canaletto o roble ahumado.

Nachttisch reversibel mit Korpus lackiert titan, graphite oder weiß gaufriert. Schubladenelement in Nussbaum Canaletto oder "verbrannte Eiche".

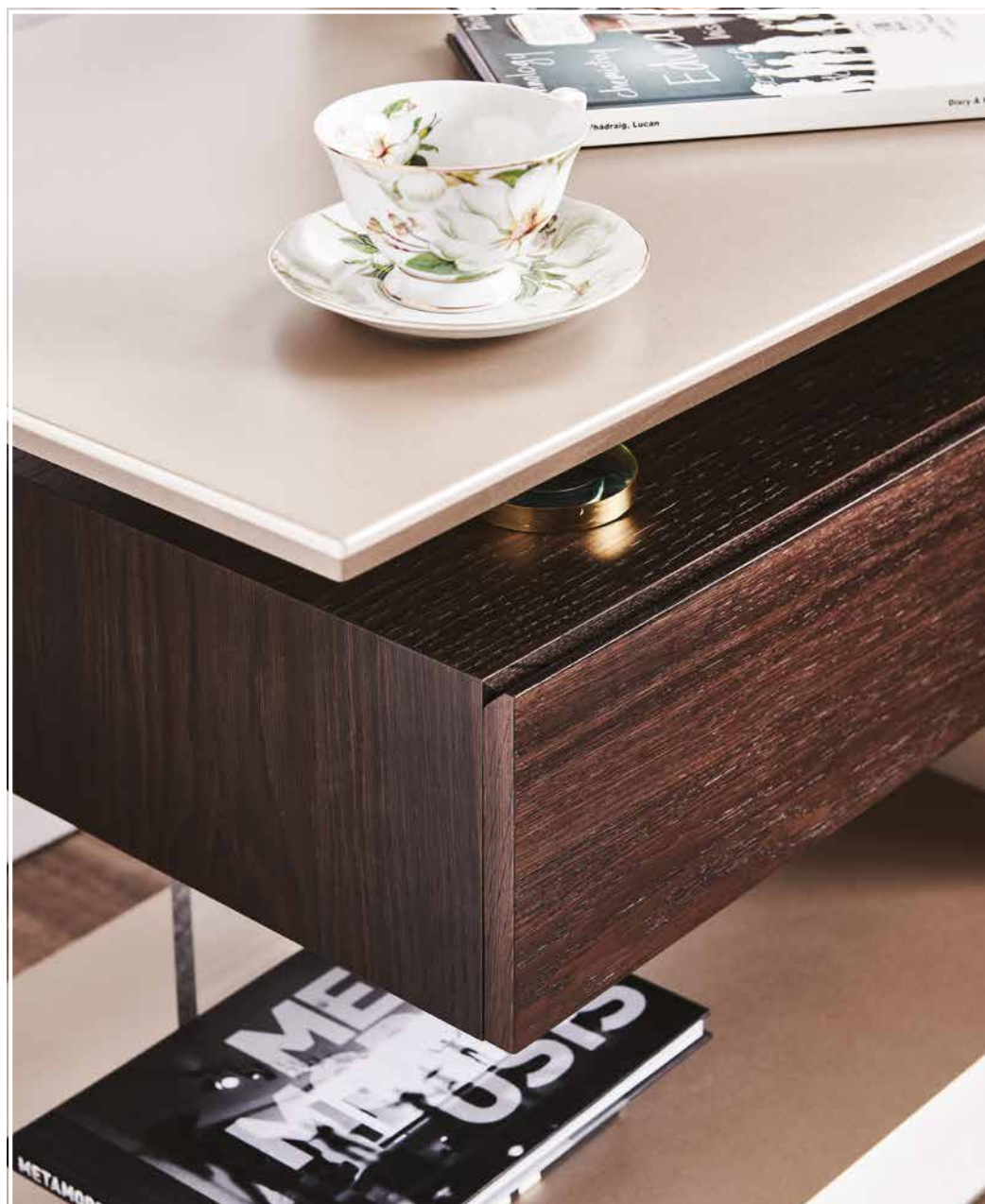
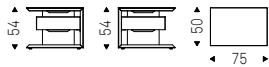





MARLON**Design Archirivolto**

Letto con struttura in legno noce Canaletto o frassino tinto rovere bruciato. Testiera rivestita in tessuto, synthetic nubuck, micro nubuck, ecopelle o pelle nei colori come da campionario. Rete inclusa.

Bed with Canaletto walnut or burned oak stained ashwood frame. Headboard covered in fabric, synthetic nubuck, micro nubuck, synthetic leather or soft leather as per sample card. Slats included.

Lit avec structure en noyer Canaletto ou frêne teinté rouvre brûlé. Tête de lit revêtue en tissu, synthetic nubuck, micro nubuck, simili-cuir ou cuir mince selon échantillons. Sommier compris.

Cama con estructura en madera nogal Canaletto o fresno barnizado roble ahumado. Cabecera tapizada en tejido, synthetic nubuck, micro nubuck, ecopiel o piel según muestrario. Somier incluido.

Bett mit Gestell in Nussbaum Canaletto oder Esche gebeizt "verbrannte Eiche". Kopfteil bezogen in Stoff, synthetic nubuck, micro nubuck, Kunstleder oder Softleder laut Musterkarte. Lattenrost inklusive.

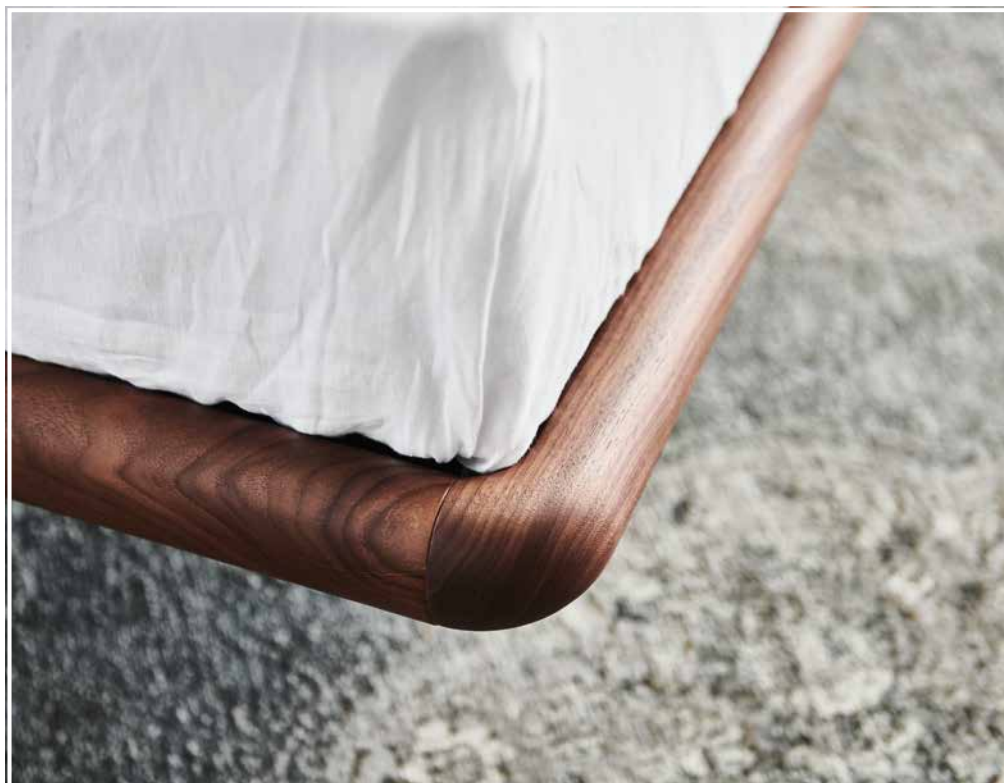
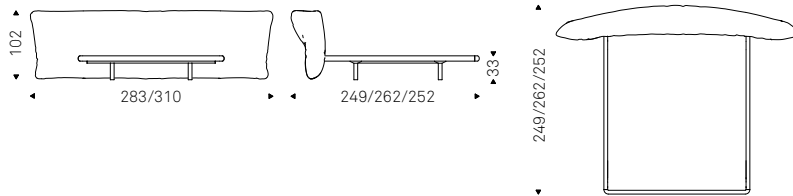





MARLON bed with Canaletto walnut frame and headboard in B232 fabric - SUNSET lamp - BILLY coffee table - CHENNAI rug - WISH MAGNUM mirror with Brushed Bronze frame













9 COLLECTION



cattelan
italia

CATTELANITALIA.COM



CATTELAN ITALIA SPA - via pilastri 19 - 36010 Carrè / Vicenza - Italy
phone +39 0445 318711 - fax +39 0445 314289 - email: info@cattelanitalia.com