

LIVE

L'ECCELLENZA DELLA SEMPLICITÀ THE EXCELLENCE OF SIMPLICITY

VISIONAIR

Ogni processo creativo ha inizio con una visione. Un nuovo punto di vista in grado di ribaltare la normalità. La cappa diventa verticale ed ergonomica, aderisce alla parete come un quadro, si trasforma in un oggetto unico dal design essenziale. E ancora, eleva l'ambiente cucina reinventandosi come elemento di arredamento, per poi trasformarsi in un punto luce sorprendente ed emozionale. Stupire significa trasformare un semplice elettrodomestico come la cappa in qualcosa di spiazzante, funzionale e meravigliosamente diverso, in una parola: *Visionair*.

Every creative process begins with a vision: a new point of view capable of overturning normality: the hood becomes vertical and ergonomic, it adheres to walls like a painting and becomes a unique object with an essential design. It also elevates the kitchen environment by reinventing itself as an element of furniture, only to turn into a surprising and emotional lighting point. To astonish means transforming a simple appliance like a kitchen hood into something surprising, functional and wonderfully different, in one word: *Visionair*.

IL FUTURO È DI CHI INNOVA

THE FUTURE IS FOR
THOSE WHO INNOVATE

Tutto nasce da un'intuizione di Ermanno Casoli, che nel 1972 realizza la sua prima cappa. Da allora, non abbiamo mai smesso di unire know-how tecnologico e design, con un solo obiettivo: rivoluzionare l'immagine della cappa da cucina nel mondo.

Oggi siamo presenti in molti Paesi, dall'America all'Asia, fieri della nostra italianità e della nostra visione internazionale. Una cultura aziendale tesa sempre all'innovazione.

La qualità dell'aria e le sue infinite sfumature, lo stile unico del Made in Italy: questo è ciò che ci ispira, che da sempre ci guida verso il futuro.

It all began from an intuition by Ermanno Casoli, who in 1972 made his first hood. Since then, we have never ceased to combine technological know-how and design, with only one objective: to revolutionize the image of kitchen hoods throughout the world.

Today we are present in numerous countries, from America to Asia, and we're proud of our Italian spirit and our international vision. A corporate culture that is always aimed at innovating.

The quality of the air and its infinite nuances, the unique Made in Italy style: this is what inspires us, which has always guided us towards the future.

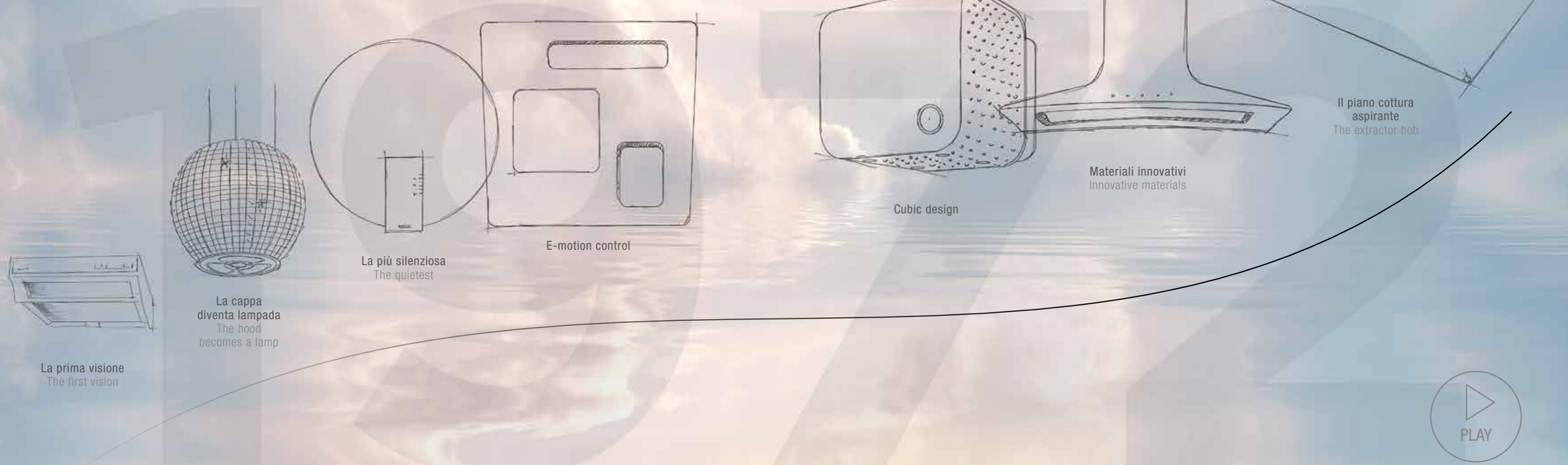

La prima visione
The first vision

La cappa
diventa lampada
The hood
becomes a lamp

La più silenziosa
The quietest

E-motion control

Cubic design

Materiali innovativi
Innovative materials

Il piano cottura
aspirante
The extractor hob



WALL 12



ACUTA
61



FLAT GLASS
45



LOL
31



SPOT NG
39



SYNTHESIS
64



BELT
28



FLAT GLASS
PLUS
43



MISSY
57



SPOT NG
URBAN
35



TAMAYA
56



CIRCUS
51



HYDRA
62



PERSONAL
63



SPOT PLUS
36



TONDA
58



CIRCUS PLUS
49



JOY
38



REEF
50



STONE
54



TRIBE
44



CRUISE
37



KUADRA
55



RUBINO
CORNER
65



STRIPE
23



TUBE PRO
53

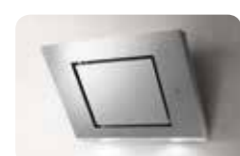

ELEKTRA
29



L'ESSENZA
17



SHIRE
27



STRIPE
URBAN
21



VEGA
59

110 ADD OR REPLACE

- 112 APPROFONDIMENTI
FURTHER
INFORMATION
- 114 ACCESSORI
ACCESSORIES
- 120 TU E LA CAPP
THE HOOD AND YOU
- 123 GARANZIA E SERVIZI
GUARANTEE AND
SERVICES

ISLAND 66



CIRCUS PLUS
ISLAND
76



REEF
ISLAND
77



FLAT GLASS
PLUS ISLAND
74



SPOT PLUS
ISLAND
73



JOY ISLAND
71



TRIBE
ISLAND
75



KUADRA
ISLAND
79



TUBE PRO
ISLAND
78

CEILING 80



CLOUD
SEVEN
85

SUSPENDED 86



JUNO
92



NAKED
93



JUNO
URBAN
91



NAKED
URBAN
95

BUILT-IN 96



BOX IN
104



ELITE 35
106



ERA S
101



ELIBLOC HT
105



ERA
103



ESTRAIBILE
108



ELITE 14
107



ERA C
102



KREA
109

INQUADRA E SCOPRI FRAME AND DISCOVER



Usa il tuo smartphone e inquadra le immagini con l'icona PLAY per avere accesso a contenuti speciali.

Use your smartphone and frame the images with the PLAY icon to get access to special contents.

Scarica gratuitamente l'applicazione Hp Reveal da App Store o da Google Play, crea il tuo account e cerca Elica. Seguici e sarà sufficiente puntare l'immagine con il PLAY per animarla.

Download the Hp Reveal app for free from the App Store or Google Play, create your account and search for Elica. Follow us and all you need to do is point at the image with PLAY to animate it.



DOWNLOAD
HP REVEAL
E CREA IL TUO
UTENTE

DOWNLOAD HP
REVEAL AND
CREATE YOUR
USER



CERCA E SEGUI
ELICA SU
HP REVEAL

SEARCH AND
FOLLOW ELICA
ON HP REVEAL



GUARDA LE
IMMAGINI
PRENDERE VITA

WATCH THE
IMAGES
COME TO LIFE

PLUS PRODOTTI PRODUCT PLUS



SMART INSTALLATION

Elica pensa il prodotto a tutto tondo, tenendo in grande considerazione anche la fase di installazione di una cappa sia essa a parete che ad incasso, sia un piano aspirante. Le operazioni di montaggio e collegamento sono semplici e intuitive.

Elica thinks of every aspect of the product, taking into great consideration even the installation phase of a hood, be it wall-mounted or recessed, or an aspiration hob. Assembly and connection operations are simple and intuitive.



BACK ASPIRATION

Maggiore flessibilità di installazione nelle cappe equipaggiate con questo particolare convogliatore dall'uscita aggiuntiva. Il funzionamento in aspirante può avvenire collegando la cappa direttamente al muro posteriore, eliminando l'utilizzo di camini e preservando l'estetica originale del prodotto.

Greater installation flexibility for hoods equipped with this particular conveyor with additional outlet. The aspiration function can be done by connecting the hood directly to the rear wall, avoiding the need for ducting and preserving the product's original aesthetics.



LONG LIFE FILTER

Filtro odori con la caratteristica principale di poter essere rigenerato e conservare le sue caratteristiche durando fino a 3 anni, evitando inutili sostituzioni e sprechi. Ha un livello elevato di efficienza che si aggira intorno al 60%.

Air filter that can be regenerated and keeps its characteristics for up to 3 years, avoiding unnecessary replacements and waste. It has a superior level of efficiency of around 60%.





WALL

Spesso è un quadro a valorizzare una parete: un'opera d'arte che non sfugge allo sguardo. La stessa attenzione la cattura L'Essenza, con il suo design magnetico e minimalista.

It often takes a painting to enhance a wall: a work of art that grabs your attention. The same attention captured by L'Essenza, with its magnetic and minimalist design.

L'ESSENZA

DESIGN FABRIZIO CRISÀ





L'ESSENZA

DESIGN FABRIZIO CRISÀ

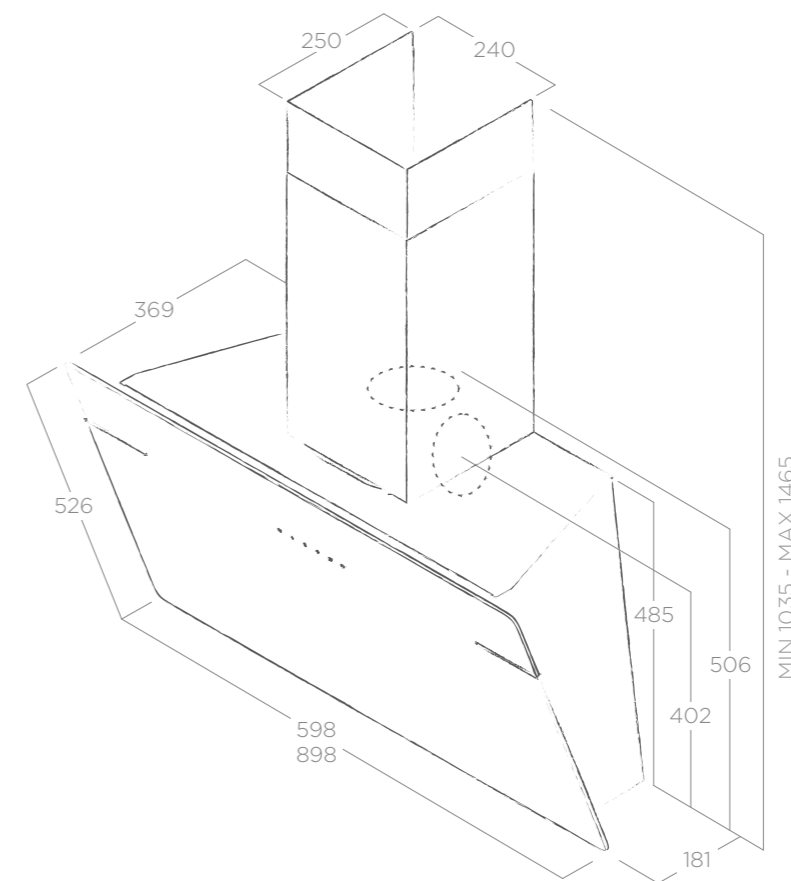

BACK
ASPIRATION



ENERGY
CLASS



SMART
INSTALLATION



CM 45



CM 50

SCHEDA TECNICA TECHNICAL FEATURES

Misure Size	60 - 90 cm
Versione Version	Aspirante Duct-out
Finiture Finish	Vetro nero - Vetro bianco Black glass - White glass

ACCESSORI ACCESSORIES

Filtro carbone Charcoal Filter	CFC0140343
--------------------------------	------------

ILLUMINAZIONE LIGHTING

Tipo Type	LED 2 x 2,5 W
Intensità Intensity	145 LUX
Temperatura Temperature	3500 K

PERFORMANCE PERFORMANCE

Comandi Controls	Touch Control 3V+I 3S+B Touch Control
Portata intensiva Booster airflow	690 m ³ /h
Livello sonoro Noise level	65 db(A)
Assorbimento totale Total absorption	255 W
Uscita Duct size	150 mm
Classe energetica Energy class	B (A**/E)

MODELLI MODELS

L'ESSENZA BL/A/60	PRF0117403A
L'ESSENZA BL/A/90	PRF0117374A
L'ESSENZA WH/A/60	PRF0124233A
L'ESSENZA WH/A/90	PRF0124234A

Filtro grassi alluminio incluso Grease aluminium Filter included

STRIPE URBAN





STRIPE URBAN

ELICA DESIGN CENTER

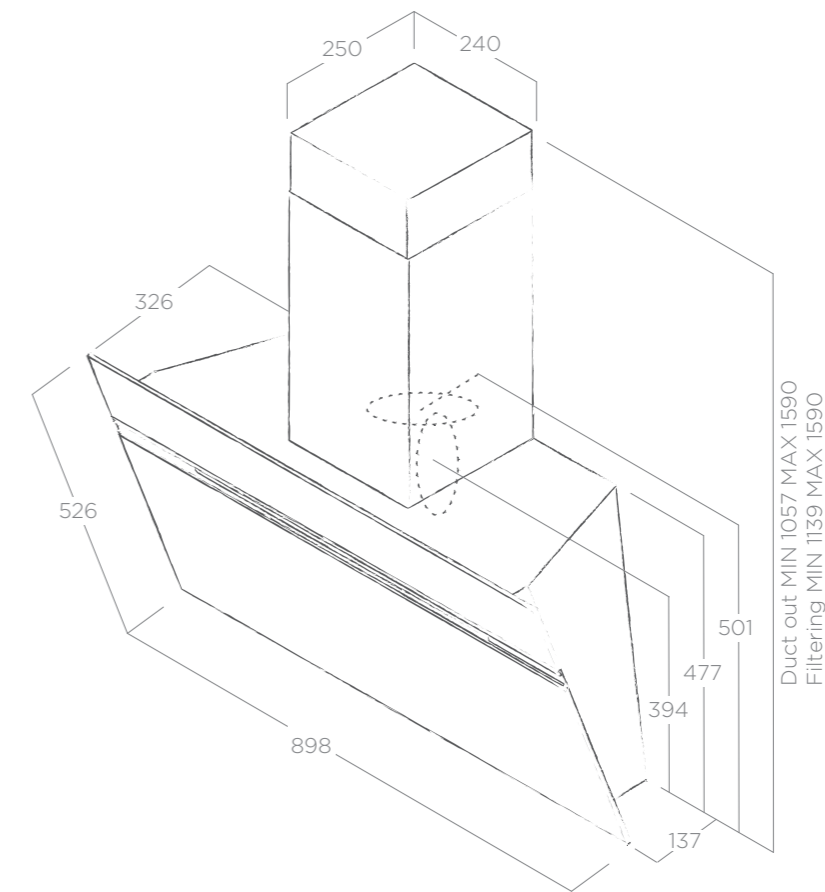

BACK
ASPIRATION



ENERGY
CLASS



SMART
INSTALLATION



CM 45



CM 65

SCHEDA TECNICA TECHNICAL FEATURES

Misure Size	90 cm
Versione Version	Aspirante Duct-out
Finiture Finish	Effetto ghisa - Effetto zincato Cast iron effect - Zinc coating effect

ACCESSORI ACCESSORIES	
Filtro carbone Charcoal Filter	CFC0140343

ILLUMINAZIONE LIGHTING	
Tipo Type	LED 2 x 2,5 W
Intensità Intensity	203 LUX
Temperatura Temperature	3500 K

PERFORMANCE PERFORMANCE	
Comandi Controls	Touch Control 3V+I 3S+B Touch Control
Portata intensiva Booster airflow	755 m ³ /h
Livello sonoro Noise level	65 db(A)
Assorbimento totale Total absorption	265 W
Uscita Duct size	150 mm
Classe energetica Energy class	B (A**/E)

Filtro grassi alluminio incluso Grease aluminium Filter included

MODELLI MODELS	
STRIPE URBAN CAST IRON/A/90	PRF0147738
STRIPE URBAN ZINC/A/90	PRF0147739



STRIPE

ELICA DESIGN CENTER

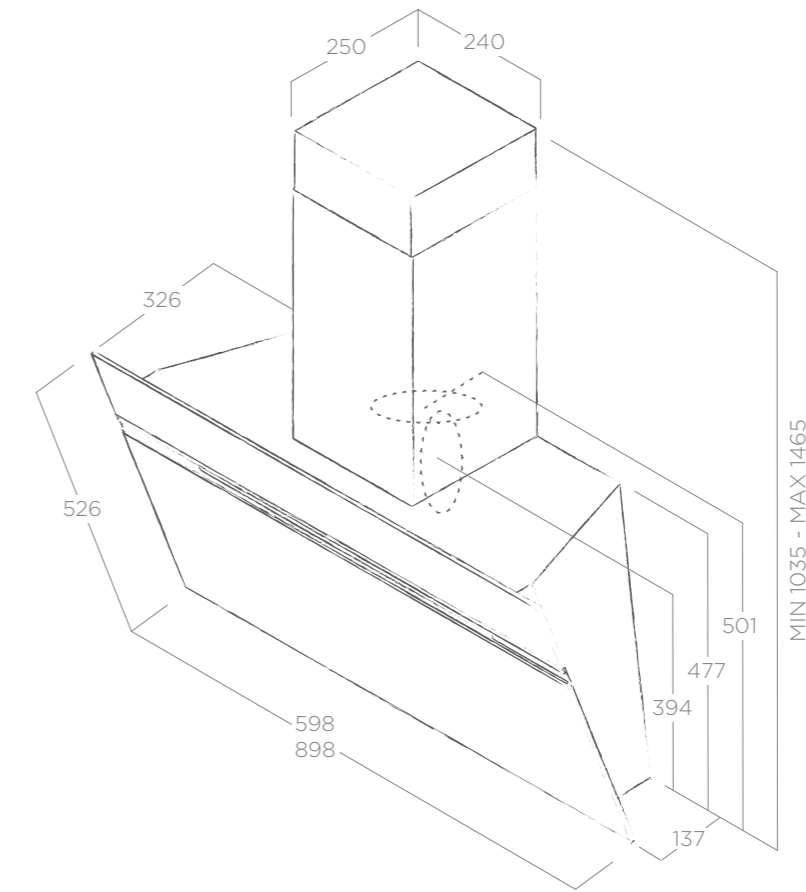

BACK ASPIRATION



ENERGY CLASS



SMART INSTALLATION



CM 45



CM 65

SCHEDA TECNICA TECHNICAL FEATURES

Misure Size	60 - 90 cm
Versione Version	Aspirante Duct-out
Finiture Finish	Vetro nero - Vetro bianco - Acciaio inox Black glass - White glass Stainless steel

ACCESSORI ACCESSORIES	
Filtro carbone Charcoal Filter	CFC0140343

ILLUMINAZIONE LIGHTING	
Tipo Type	LED 2 x 2,5 W
Intensità Intensity	203 LUX
Temperatura Temperature	3500 K

PERFORMANCE PERFORMANCE	
Comandi Controls	Touch Control 3V+I 3S+B Touch Control
Portata intensiva Booster airflow	755 m ³ /h
Livello sonoro Noise level	65 db(A)
Assorbimento totale Total absorption	265 W
Uscita Duct size	150 mm
Classe energetica Energy class	B (A ⁺ /E)

MODELLI MODELS	
STRIPE BL/A/60	PRF0101142B
STRIPE BL/A/90	PRF0101143B
STRIPE WH/A/60	PRF0101144B
STRIPE WH/A/90	PRF0101145B
STRIPE IX/A/60	PRF0110514B
STRIPE IX/A/90	PRF0110515B

Filtro grassi alluminio incluso Grease aluminium Filter included

SHIRE

DESIGN FABRIZIO CRISÀ





SHIRE

DESIGN FABRIZIO CRISÀ

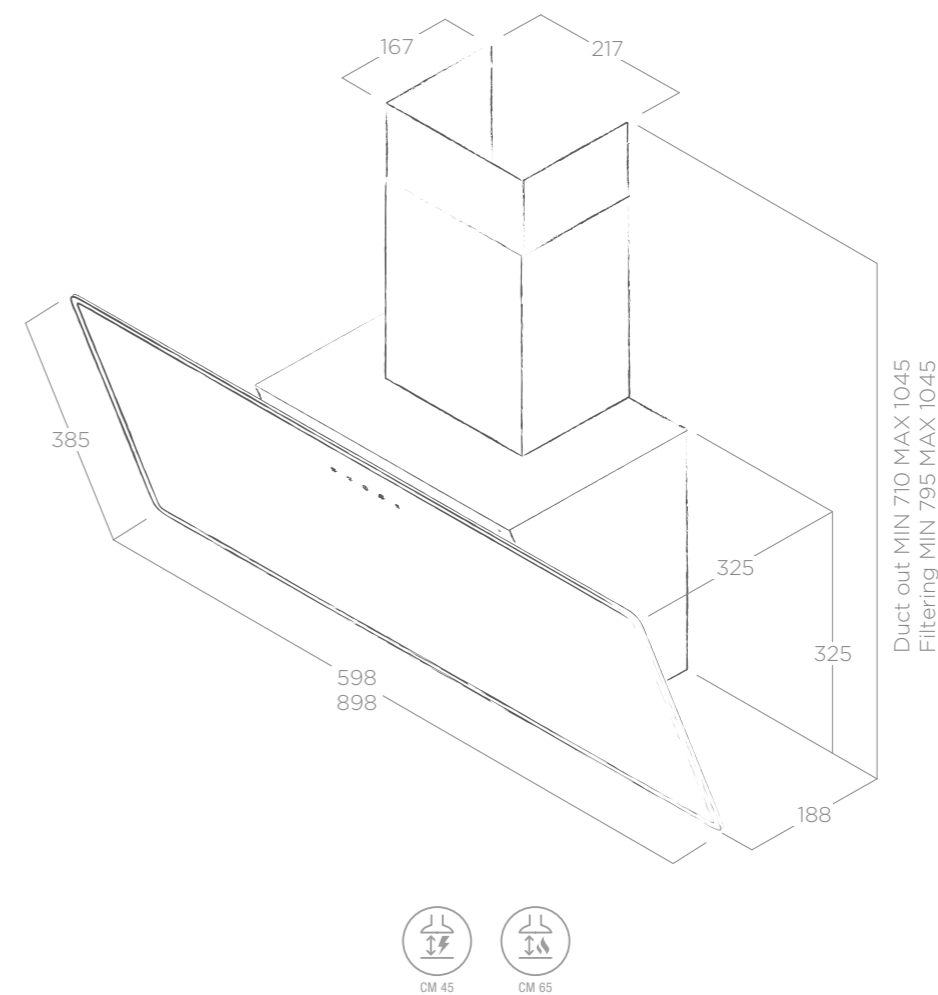

SMART
INSTALLATION

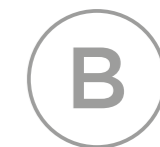

ENERGY
CLASS

WALL

SCHEDA TECNICA TECHNICAL FEATURES

Misure Size 60 - 90 cm
Versione Version Aspirante Duct-out
Finiture Finish Vetro nero - Vetro bianco
Black glass - White glass

ACCESSORI ACCESSORIES

Filtro carbone Charcoal Filter CFC0140343

ILLUMINAZIONE LIGHTING

Tipo Type LED 2 x 1 W
Intensità Intensity 58 LUX
Temperatura Temperature 4000 K

PERFORMANCE PERFORMANCE

Comandi Controls Touch Control 2V+I
2S+B Touch Control
Portata intensiva Booster airflow 710 m³/h
Livello sonoro Noise level 60 db(A)
Assorbimento totale Total absorption 272 W
Uscita Duct size 150 mm
Classe energetica Energy class B (A**/E)

MODELLI MODELS

SHIRE BL/A/60 PRF0119819
SHIRE BL/A/90 PRF0119829
SHIRE WH/A/60 PRF0119823
SHIRE WH/A/90 PRF0119828

Filtro grassi alluminio incluso Grease aluminium Filter included

BELT

DESIGN FABRIZIO CRISA



SCHEDA TECNICA TECHNICAL FEATURES

Misure Size	55 - 80 cm
Versione Version	Filtrante Recycling
Finiture Finish	Vetro nero - Vetro bianco - Acciaio Inox Black glass- White glass - Stainless steel

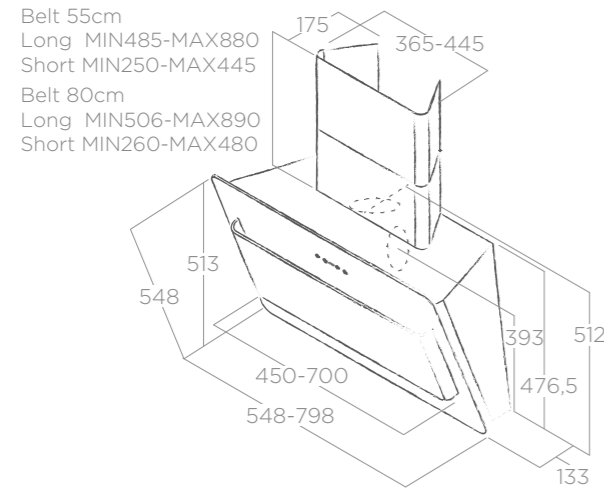

ILLUMINAZIONE LIGHTING

Tipo Type	LED 2 x 2,5 W
Intensità Intensity	301 LUX
Temperatura Temperature	3000 K

PERFORMANCE PERFORMANCE

Comandi Controls	Touch Control 3V+I 3S+B Touch Control
Portata intensiva Booster airflow	690 m³/h
Livello sonoro Noise level	68 db(A)
Assorbimento totale Total absorption	265W
Uscita Duct size	150 mm
Classe energetica Energy class	C (A++/E)

Filtro grassi alluminio incluso Grease aluminium Filter included
Filtro carbone incluso Charcoal Filter included

ACCESSORI ACCESSORIES

Filtro carbone Charcoal Filter	CFC0140343
Kit camino lungo Long chimney kit (80)	KIT0010439
Kit camino corto Short chimney kit (80)	KIT0010700
Kit camino lungo Long chimney kit (55)	KIT0010519
Kit camino corto Short chimney kit (55)	KIT0010701

MODELLI MODELS

BELT BL/F/55	PRF0034211B
BELT BL/F/80	PRF0032793B
BELT IX/F/55	PRF0034012B
BELT IX/F/80	PRF0033852B
BELT WH/F/55	PRF0038445B
BELT WH/F/80	PRF0038443B

ELEKTRA

ELICA DESIGN CENTER



SCHEDA TECNICA TECHNICAL FEATURES

Misure Size	55 - 80 cm
Versione Version	Filtrante Recycling
Finiture Finish	Acciaio Inox Stainless steel

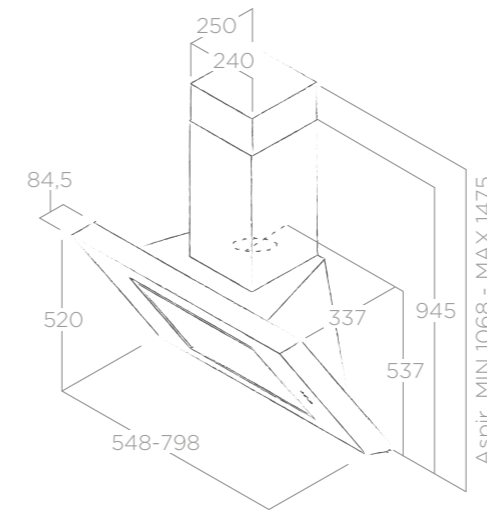

ILLUMINAZIONE LIGHTING

Tipo Type	LED 2 x 1 W
Intensità Intensity	141 LUX
Temperatura Temperature	3500 K

PERFORMANCE PERFORMANCE

Comandi Controls	Touch Control con display 3V+I 3S+B Touch Control with display
Portata intensiva Booster airflow	645 m³/h
Livello sonoro Noise level	63 db(A)
Assorbimento totale Total absorption	255W
Uscita Duct size	150 mm
Classe energetica Energy class	C (A++/E)

Filtro grassi alluminio incluso Grease aluminium Filter included
Filtro lunga durata Long Life Filter included

ACCESSORI ACCESSORIES

Filtro lunga durata Long Life Filter	CFC0140088
Kit camino Chimney kit	KIT0008747A

MODELLI MODELS

ELEKTRA IX/F/55	PRF0006407B
ELEKTRA IX/F/80	PRF0006872B





LOL

ELICA DESIGN CENTER

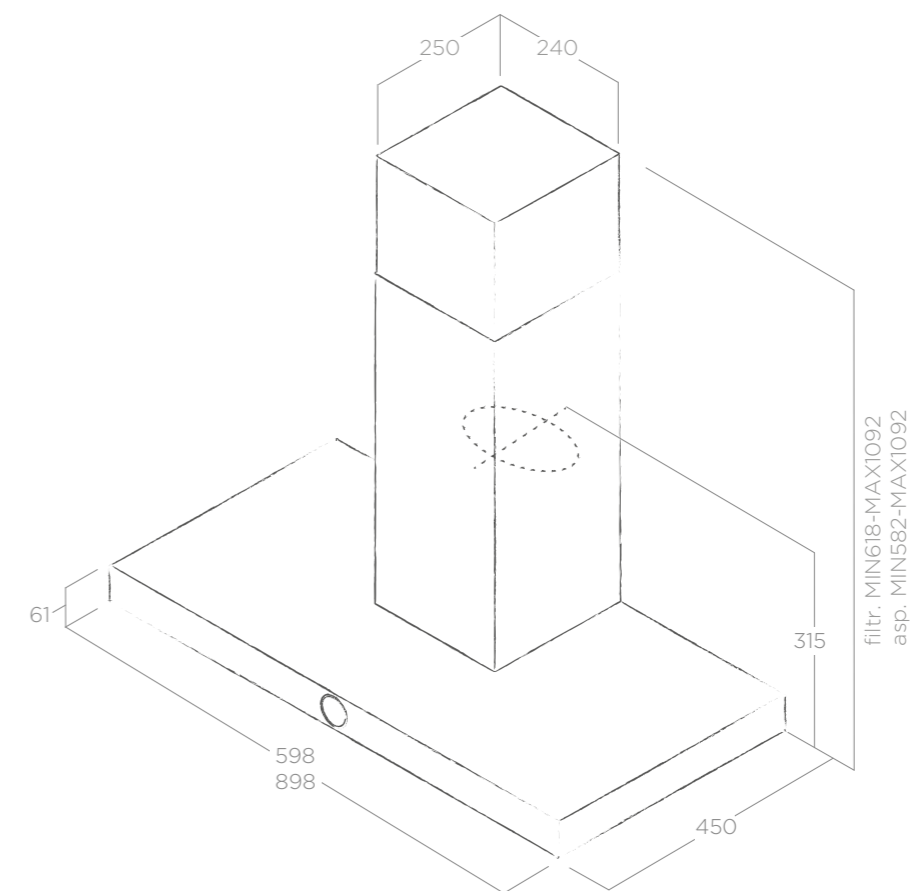

SMART
INSTALLATION



ENERGY
CLASS



LONG LIFE
FILTER



CM 50



CM 65

SCHEDA TECNICA TECHNICAL FEATURES

Misure Size	60 - 90 cm
Versione Version	Aspirante Duct-out
Finiture Finish	Nero goffrato - Acciaio inox Embossed black - Stainless steel

ACCESSORI ACCESSORIES

Filtro carbone Charcoal filter	CFC0141529
Filtro lunga durata Long life filter	CFC0141725

ILLUMINAZIONE LIGHTING

Tipo Type	LED 2 x 2,5 W
Intensità Intensity	145 LUX
Temperatura Temperature	3500 K

PERFORMANCE PERFORMANCE

Comandi Controls	Rotativo Elettronico 3V+I 3S+B Electronic Rotative
Portata intensiva Booster airflow	665 m ³ /h
Livello sonoro Noise level	65 db(A)
Assorbimento totale Total absorption	260 W
Uscita Duct size	150 mm
Classe energetica Energy class	B (A**/E)

MODELLI MODELS

LOL BL/A/60	PRF0097782
LOL BL/A/90	PRF0097906
LOL IX/A/60	PRF0097149
LOL IX/A/90	PRF0097323

Filtro grassi alluminio incluso Grease aluminium Filter included

SPOT NG URBAN





SPOT NG URBAN

ELICA DESIGN CENTER

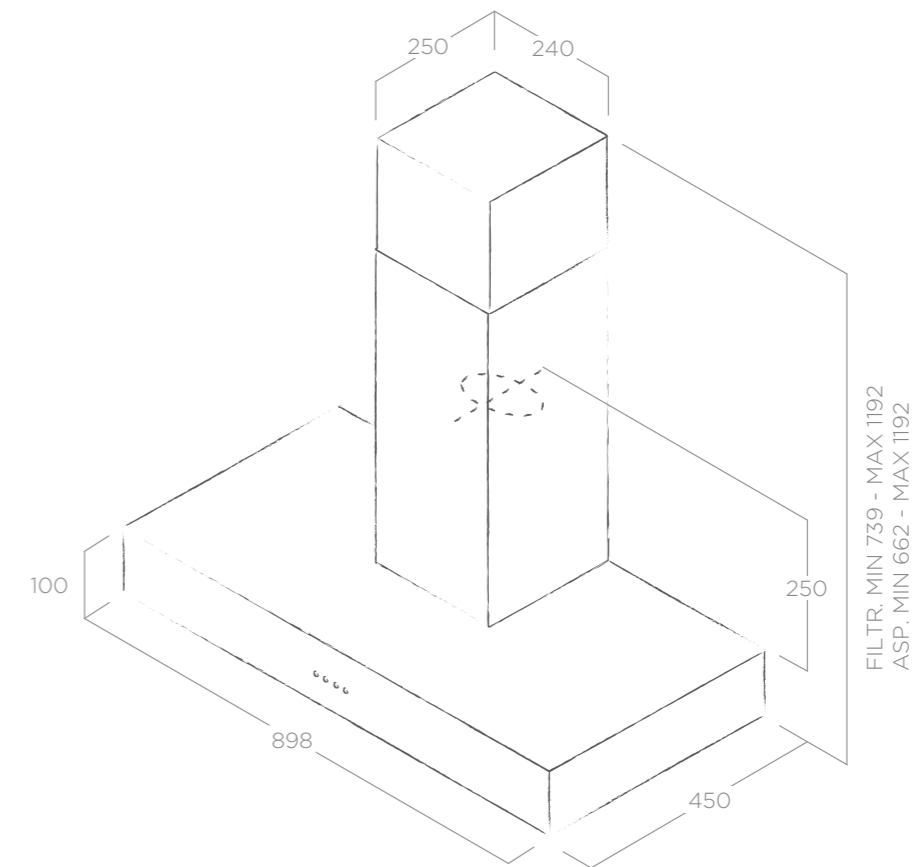

LONG LIFE FILTER



ENERGY CLASS



CM 50



CM 65



SCHEDA TECNICA TECHNICAL FEATURES

Misure Size	90 cm
Versione Version	Aspirante Duct-out
Finiture Finish	Effetto ghisa - Effetto zinco Cast iron effect - Zinc coating effect

ACCESSORI ACCESSORIES

Filtro carbone Charcoal filter	CFC0141529
Filtro lunga durata Long life filter	CFC0141725

ILLUMINAZIONE LIGHTING

Tipo Type	LED 2 x 2,5 W
Intensità Intensity	140 LUX
Temperatura Temperature	3500 K

PERFORMANCE PERFORMANCE

Comandi Controls	Pulsantiera Meccanica 3V 3S Mechanical Push Button
Portata massima Max airflow	600 m ³ /h
Livello sonoro Noise level	69 db(A)
Assorbimento totale Total absorption	255 W
Uscita Duct size	150 mm
Classe energetica Energy class	B (A ⁺⁺ /E)

MODELLI MODELS

Filtro grassi alluminio incluso Grease aluminium Filter included	
--	--

SPOT URBAN CAST IRON/A/90	PRF0147736
SPOT URBAN ZINC/A/90	PRF0147737

SPOT PLUS

ELICA DESIGN CENTER



SCHEDA TECNICA TECHNICAL FEATURES

Misure Size	60 - 90 - 120 cm
Versione Version	Aspirante Duct out
Finiture Finish	Acciaio inox Stainless steel

VERSIONE A ISOLA PAG. 73

ISLAND VERSION P. 73

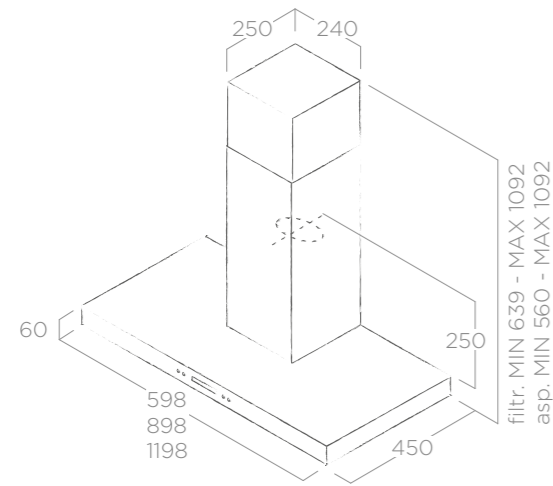

ILLUMINAZIONE LIGHTING

Tipo Type	LED 2 x 2,5 W
Intensità Intensity	145 LUX
Temperatura Temperature	4000 K

PERFORMANCE PERFORMANCE

Comandi Controls	LCD 3V+I LCD 3S+I
Portata intensiva Booster airflow	625 m³/h
Livello sonoro Noise level	62 db(A)
Assorbimento totale Total absorption	265 W
Uscita Duct size	150 mm
Classe energetica Energy class	A (A**/E)

Filtro grassi alluminio incluso Grease aluminium Filter included

ACCESSORI ACCESSORIES

Filtro carbone Charcoal filter	CFC0141529
Filtro lunga durata Long life filter	CFC0141725

MODELLI MODELS

SPOT PLUS IX/A/60	PRF0097374
SPOT PLUS IX/A/90	PRF0097373
SPOT PLUS IX/A/120	PRF0100242

CRUISE

ELICA DESIGN CENTER

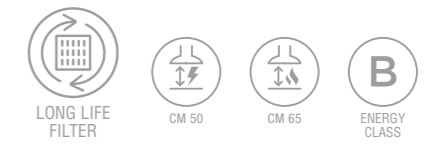

SCHEDA TECNICA TECHNICAL FEATURES

Misure Size	60 - 90 cm
Versione Version	Aspirante Duct out
Finiture Finish	Acciaio inox Stainless steel

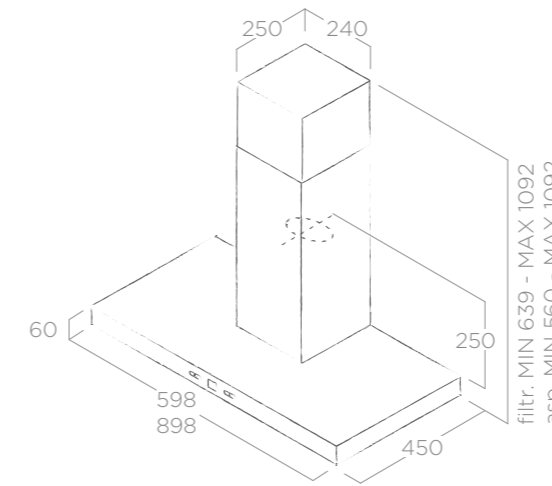

ILLUMINAZIONE LIGHTING

Tipo Type	LED 2 x 2,5 W
Intensità Intensity	145 LUX
Temperatura Temperature	3500 K

PERFORMANCE PERFORMANCE

Comandi Controls	Touch Control con display 3V+I 3S+B Touch Control with display
Portata intensiva Booster airflow	710 m³/h
Livello sonoro Noise level	69 db(A)
Assorbimento totale Total absorption	265W
Uscita Duct size	150 mm
Classe energetica Energy class	B (A**/E)

Filtro grassi alluminio incluso Grease aluminium Filter included

ACCESSORI ACCESSORIES

Filtro carbone Charcoal Filter	CFC0141529
Filtro lunga durata Long Life Filter	CFC0141725

MODELLI MODELS

CRUISE IX/A/60	PRF0147062
CRUISE IX/A/90	PRF0147074





SCHEDA TECNICA TECHNICAL FEATURES

Misure Size	60 - 90 cm
Versione Version	Aspirante Duct out
Finiture Finish	Acciaio inox + vetro bianco, acciaio inox + vetro nero Stainless steel + white glass, stainless steel + black glass

VERSIONE A ISOLA PAG. 71 ISLAND VERSION P. 71

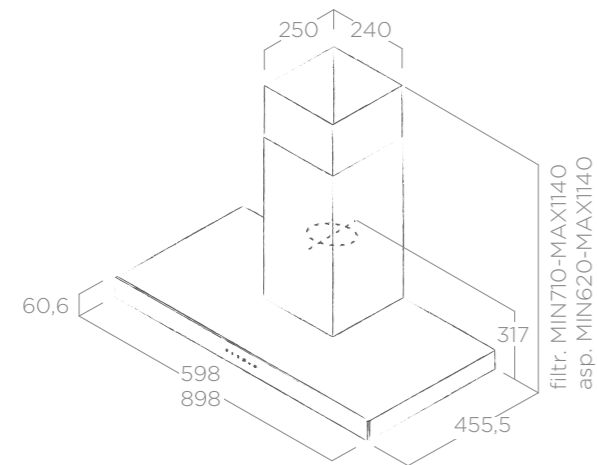

ILLUMINAZIONE LIGHTING

Tipo Type	LED 2 x 2,5 W
Intensità Intensity	141 LUX
Temperatura Temperature	3500 K

PERFORMANCE PERFORMANCE

Comandi Controls	Touch Control 3V+I 3S+B Touch Control
Portata intensiva Booster airflow	710 m³/h
Livello sonoro Noise level	69 db(A)
Assorbimento totale Total absorption	265 W
Uscita Duct size	150 mm
Classe energetica Energy class	B (A++/E)

Filtro grassi alluminio incluso Grease aluminium Filter included

ACCESSORI ACCESSORIES

Filtro carbone Charcoal filter	CFC0141529
Filtro lunga durata Long life filter	CFC0141725

MODELLI MODELS

JOY WHIX/A/60	PRF0104630A
JOY WHIX/A/90	PRF0104631A
JOY BLIX/A/60	PRF0104625A
JOY BLIX/A/90	PRF0104626A

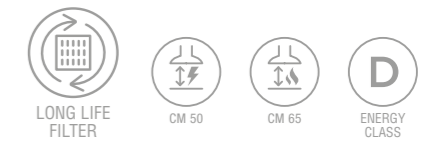

SCHEDA TECNICA TECHNICAL FEATURES

Misure Size	60 - 90 - 120 cm
Versione Version	Aspirante Duct out
Finiture Finish	Acciaio inox Stainless steel

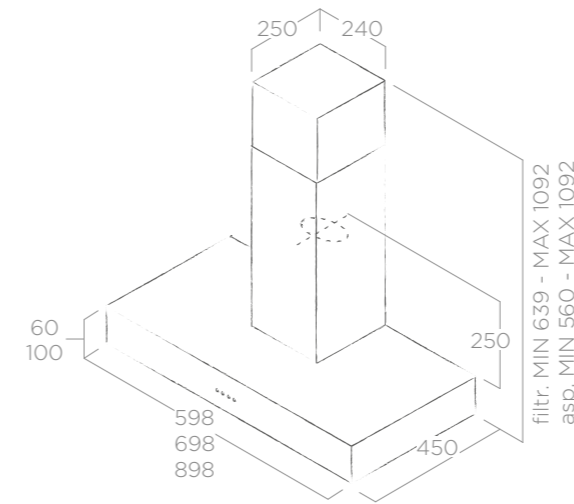

ILLUMINAZIONE LIGHTING

Tipo Type	LED 2 x 2,5 W, LED 3 x 2,5 W (120 cm)
Intensità Intensity	141 LUX, 211 LUX (120 cm)
Temperatura Temperature	3500 K

PERFORMANCE PERFORMANCE

Comandi Controls	Pulsantiera Meccanica 3V 3s Mechanical Push Button
Portata massima Max airflow	365 m³/h
Livello sonoro Noise level	62 db(A)
Assorbimento totale Total absorption	140 W, 150 W (120 cm)
Uscita Duct size	150 mm
Classe energetica Energy class	D (A++/E)

Filtro grassi alluminio incluso Grease aluminium Filter included

ACCESSORI ACCESSORIES

Filtro carbone Charcoal Filter	CFC0141529
Filtro lunga durata Long Life Filter	CFC0141725

MODELLI MODELS

SPOT NG H10 IX/A/60	55916386A
SPOT NG H10 IX/A/90	55916387A
SPOT NG H10 IX/A/120	PRF0099408A
SPOT NG H6 IX/A/60	55916388A
SPOT NG H6 IX/A/90	55916389A
SPOT NG H6 IX/A/120	PRF0099407A



FLAT GLASS PLUS





FLAT GLASS PLUS

ELICA DESIGN CENTER

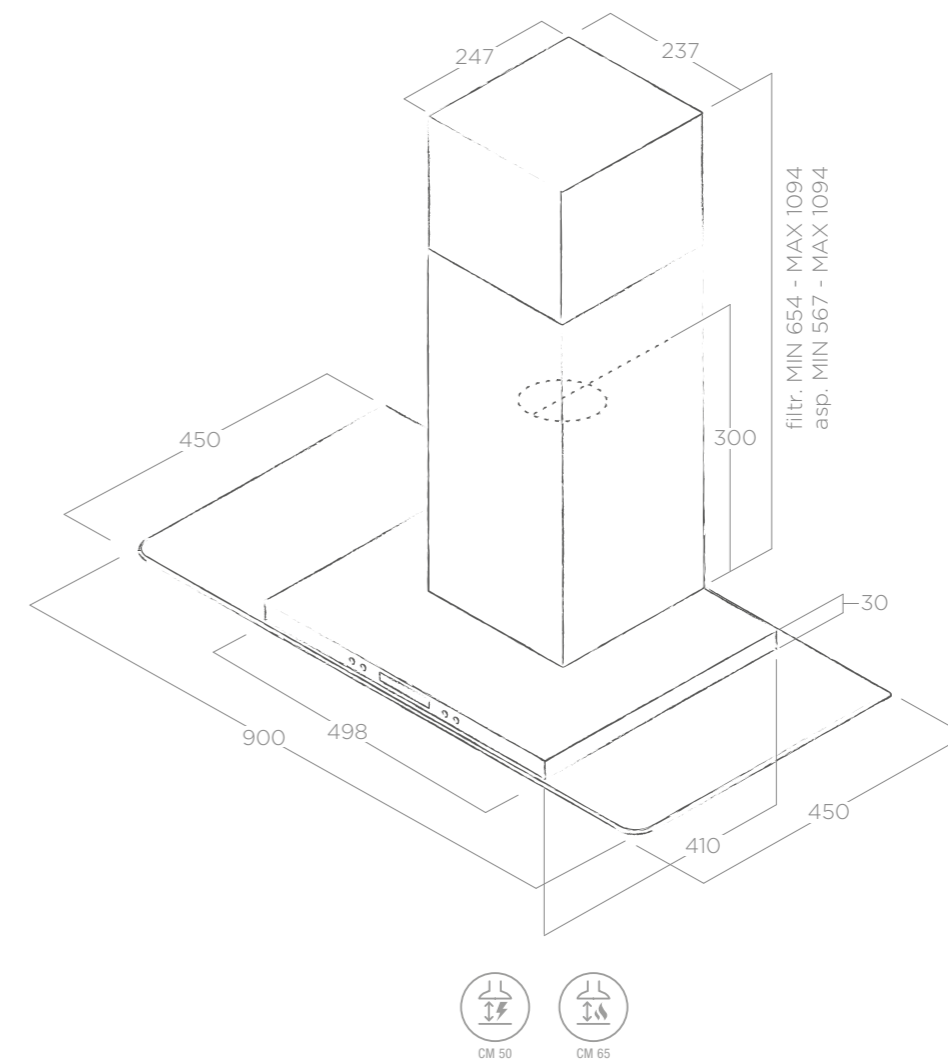

LONG LIFE FILTER



ENERGY CLASS

VERSIONE A ISOLA PAG. 74

ISLAND VERSION P. 74

SCHEDA TECNICA TECHNICAL FEATURES

Misure Size 90 cm
 Versione Version Aspirante Duct-out
 Finiture Finish Acciaio inox + vetro
 Stainless steel + glass

ACCESSORI ACCESSORIES

Filtro carbone Charcoal filter CFC0141529
 Filtro lunga durata Long life filter CFC0141725

ILLUMINAZIONE LIGHTING

Tipo Type LED 2 x 2,5 W
 Intensità Intensity 145 LUX
 Temperatura Temperature 4000 K

PERFORMANCE PERFORMANCE

Comandi Controls LCD 3V+I
 3S+B LCD
 Portata intensiva Booster airflow 600 m³/h
 Livello sonoro Noise level 62 db(A)
 Assorbimento totale Total absorption 265 W
 Uscita Duct size 150 mm
 Classe energetica Energy class A (A**/E)

MODELLI MODELS

Filtro grassi alluminio incluso Grease aluminium Filter included

FLAT GLASS PLUS IX/A/90

PRF0097368





SCHEDA TECNICA TECHNICAL FEATURES

Misure Size	60 - 90 cm
Versione Version	Aspirante Duct out
Finiture Finish	Acciaio inox + vetro Stainless steel + glass

VERSIONE A ISOLA PAG. 75 ISLAND VERSION P. 75

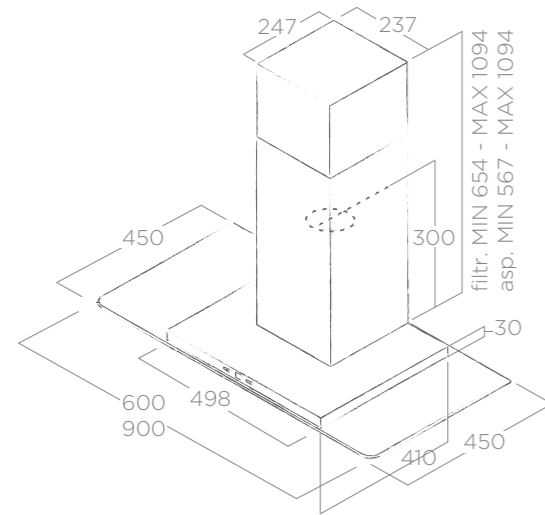

ILLUMINAZIONE LIGHTING

Tipo Type	LED 2 x 2,5 W
Intensità Intensity	145 LUX
Temperatura Temperature	3500 K

PERFORMANCE PERFORMANCE

Comandi Controls	Touch Control con display 3V+I 3S+B Touch Control with display
Portata intensiva Booster airflow	710 m ³ /h
Livello sonoro Noise level	68 db(A)
Assorbimento totale Total absorption	265 W
Uscita Duct size	150 mm
Classe energetica Energy class	B (A++/E)

Filtro grassi alluminio incluso Grease aluminium Filter included

ACCESSORI ACCESSORIES

Filtro carbone Charcoal filter	CFC0141529
Filtro lunga durata Long life filter	CFC0141725

MODELLI MODELS

TRIBE IX/A/60	PRF0049156B
TRIBE IX/A/90	PRF0049070B

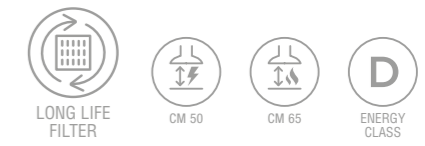

SCHEDA TECNICA TECHNICAL FEATURES

Misure Size	60 - 90 cm
Versione Version	Aspirante Duct out
Finiture Finish	Acciaio Inox + vetro Stainless steel + glass

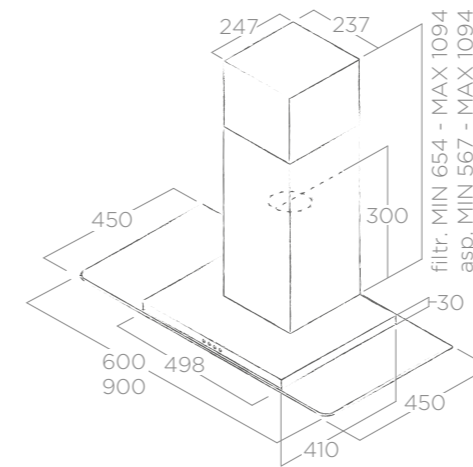

ILLUMINAZIONE LIGHTING

Tipo Type	LED 2 x 2,5 W
Intensità Intensity	141 LUX
Temperatura Temperature	3500 K

PERFORMANCE PERFORMANCE

Comandi Controls	Pulsantiera Meccanica 3V 3S Mechanical Push Button
Portata massima Max airflow	365 m ³ /h
Livello sonoro Noise level	62 db(A)
Assorbimento totale Total absorption	140 W
Uscita Duct size	150 mm
Classe energetica Energy class	D (A++/E)

Filtro grassi alluminio incluso Grease aluminium Filter included

ACCESSORI ACCESSORIES

Filtro carbone Charcoal Filter	CFC0141529
Filtro lunga durata Long Life Filter	CFC0141725

MODELLI MODELS

FLAT GLASS IX/A/60	68516391A
FLAT GLASS IX/A/90	68516390A



CIRCUS PLUS

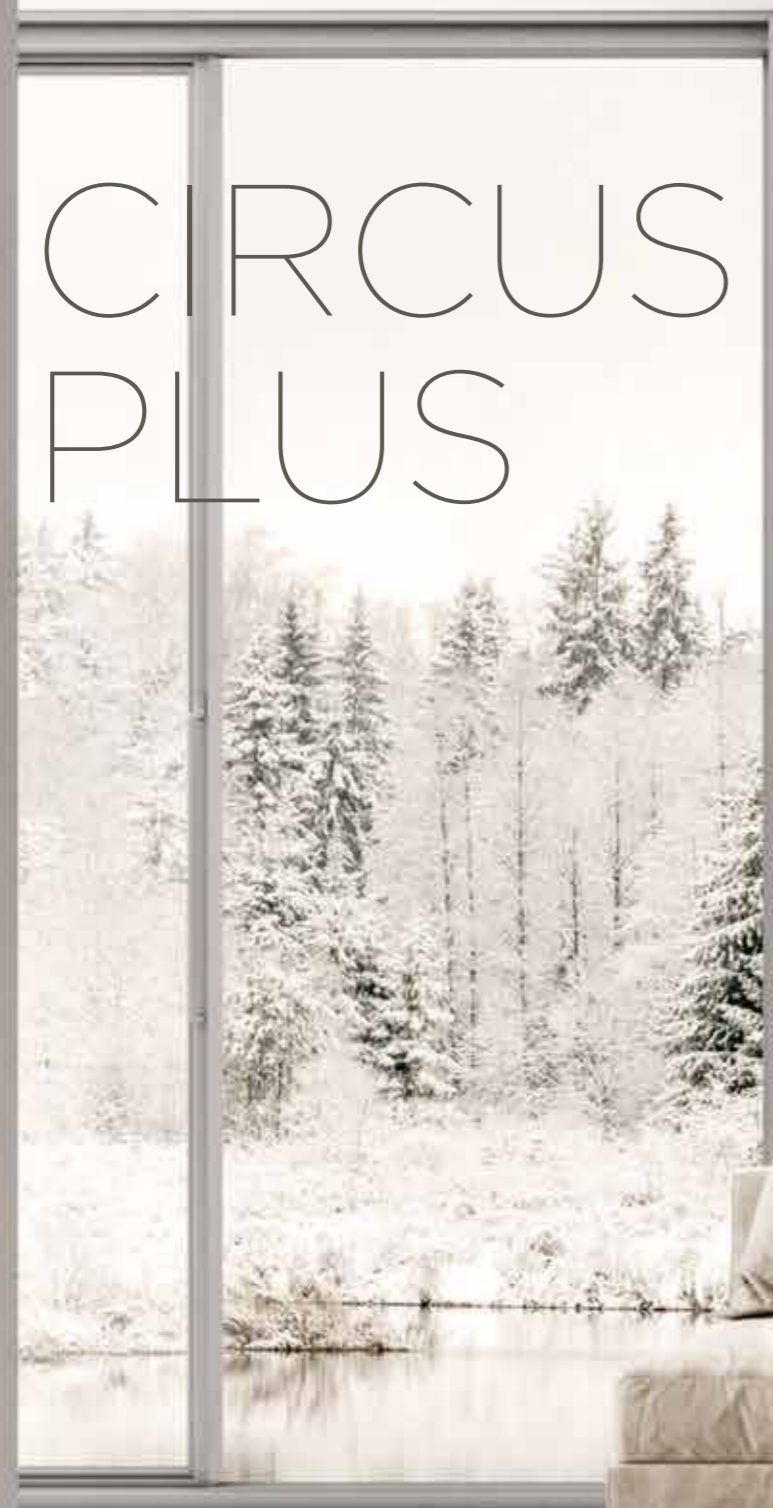



CIRCUS PLUS

ELICA DESIGN CENTER

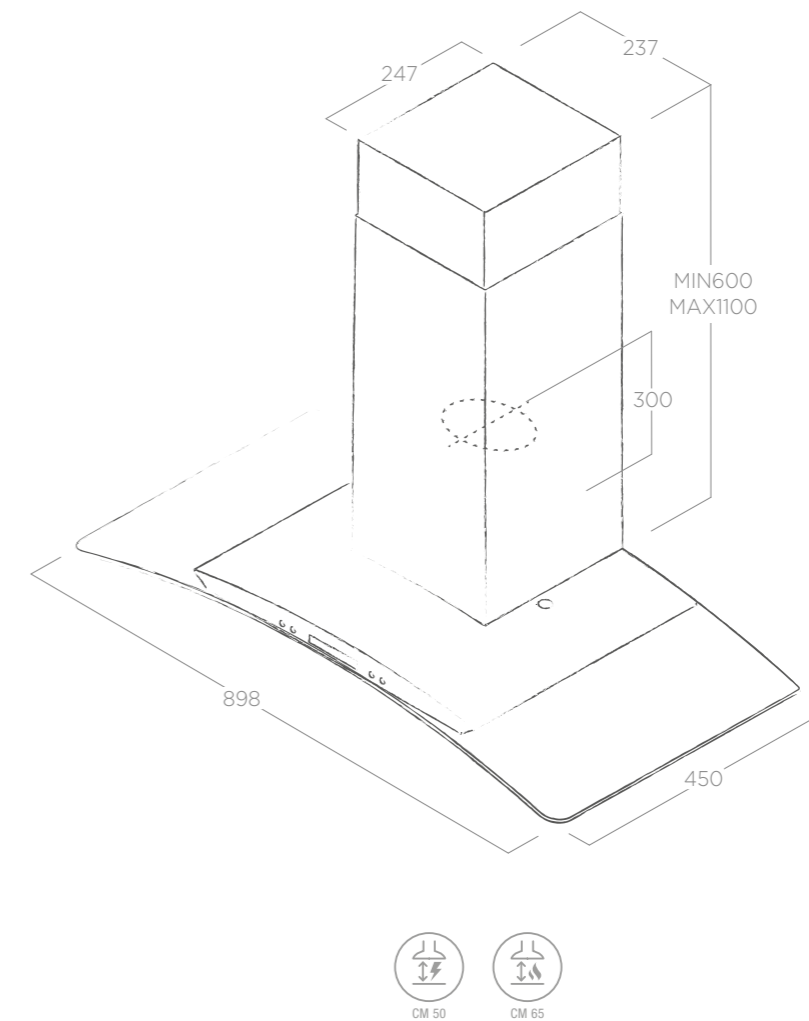

LONG LIFE FILTER



ENERGY CLASS

VERSIONE A ISOLA PAG. 76

ISLAND VERSION P. 76

SCHEDA TECNICA TECHNICAL FEATURES

Misure Size 90 cm
 Versione Version Aspirante Duct-out
 Finiture Finish Acciaio inox + vetro
 Stainless steel + glass

ACCESSORI ACCESSORIES

Filtro carbone Charcoal filter CFC0141529
 Filtro lunga durata Long life filter CFC0141725

ILLUMINAZIONE LIGHTING

Tipo Type LED 2 x 2,5 W
 Intensità Intensity 145 LUX
 Temperatura Temperature 4000 K

PERFORMANCE PERFORMANCE

Comandi Controls LCD 3V+I
 3S+B LCD
 Portata intensiva Booster airflow 600 m³/h
 Livello sonoro Noise level 62 db(A)
 Assorbimento totale Total absorption 265 W
 Uscita Duct size 150 mm
 Classe energetica Energy class A (A**/E)

MODELLI MODELS

Filtro grassi alluminio incluso Grease aluminium Filter included

CIRCUS PLUS IX/A/90

PRF0097372

REEF

ELICA DESIGN CENTER



SCHEDA TECNICA TECHNICAL FEATURES

Misure Size	60 - 90 cm
Versione Version	Aspirante Duct out
Finiture Finish	Acciaio inox + vetro Stainless steel + glass

VERSIONE A ISOLA PAG. 77

ISLAND VERSION P. 77

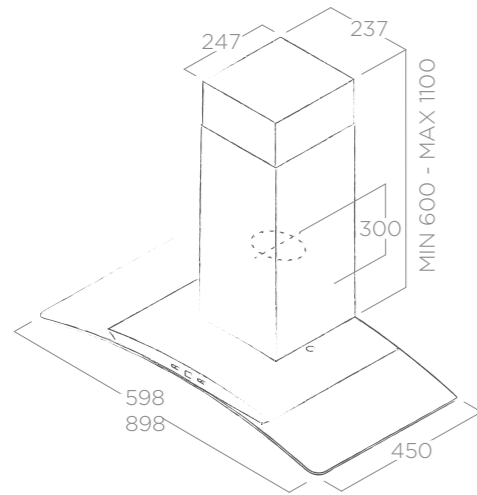

ILLUMINAZIONE LIGHTING

Tipo Type	LED 2 x 2,5 W
Intensità Intensity	145 LUX
Temperatura Temperature	3500 K

PERFORMANCE PERFORMANCE

Comandi Controls	Touch Control con display 3V+I 3S+B Touch Control with display
Portata intensiva Booster airflow	710 m³/h
Livello sonoro Noise level	68 db(A)
Assorbimento totale Total absorption	265 W
Uscita Duct size	150 mm
Classe energetica Energy class	B (A++/E)

Filtro grassi alluminio incluso Grease aluminium Filter included

ACCESSORI ACCESSORIES

Filtro carbone Charcoal filter	CFC0141529
Filtro lunga durata Long life filter	CFC0141725

MODELLI MODELS

REEF IX/A/60	PRF0048774B
REEF IX/A/90	PRF0048750B

CIRCUS

ELICA DESIGN CENTER



SCHEDA TECNICA TECHNICAL FEATURES

Misure Size	60 - 90 cm
Versione Version	Aspirante Duct out
Finiture Finish	Acciaio Inox + vetro Stainless steel + glass

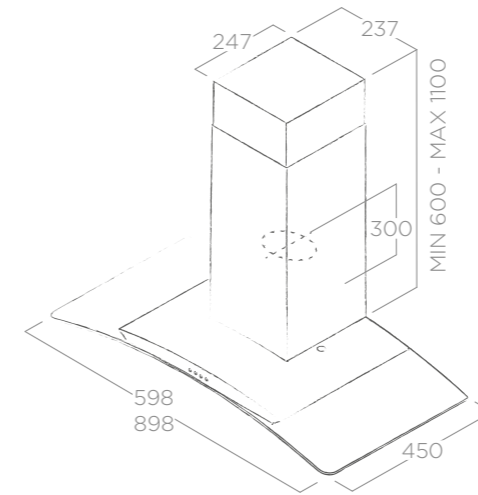

ILLUMINAZIONE LIGHTING

Tipo Type	LED 2 x 2,5 W
Intensità Intensity	141 LUX
Temperatura Temperature	3500 K

PERFORMANCE PERFORMANCE

Comandi Controls	Pulsantiera Meccanica 3V 3s Mechanical Push Button
Portata massima Max airflow	365 m³/h
Livello sonoro Noise level	62 db(A)
Assorbimento totale Total absorption	140 W
Uscita Duct size	150 mm
Classe energetica Energy class	D (A++/E)

Filtro grassi alluminio incluso Grease aluminium Filter included

ACCESSORI ACCESSORIES

Filtro carbone Charcoal Filter	CFC0141529
Filtro lunga durata Long Life Filter	CFC0141725

MODELLI MODELS

CIRCUS IX/A/60	68116393A
CIRCUS IX/A/90	68116392A





TUBE PRO

ELICA DESIGN CENTER

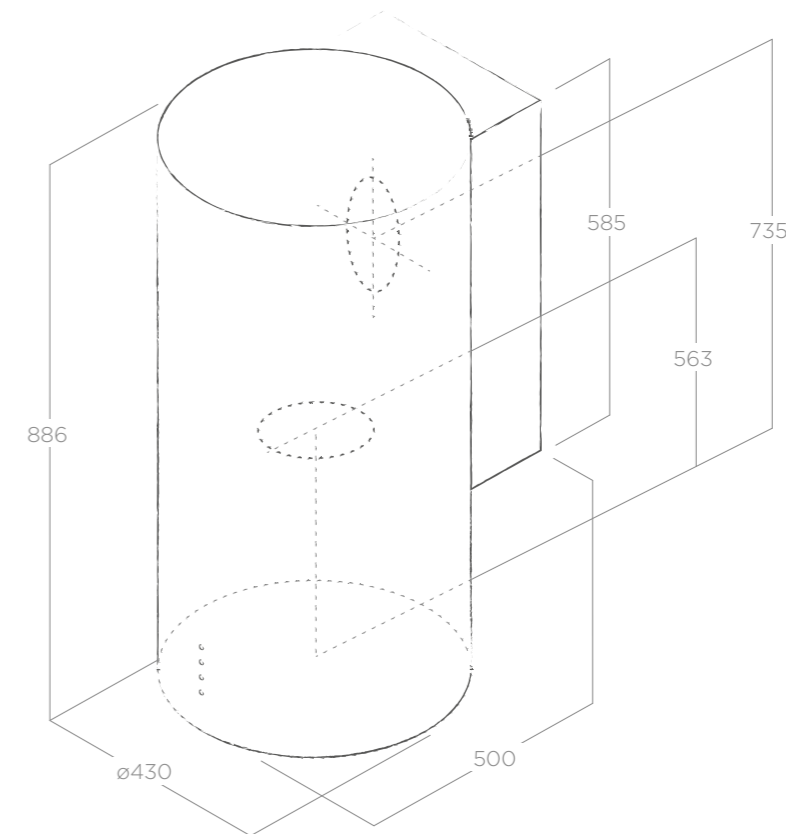

LONG LIFE FILTER



ENERGY CLASS

VERSIONE A ISOLA PAG. 78

ISLAND VERSION P. 78

SCHEDA TECNICA TECHNICAL FEATURES

Misure Size \varnothing 43 cm
 Versione Version Aspirante Duct-out
 Finiture Finish Acciaio inox, nero, bianco
 Stainless steel, black, white

ACCESSORI ACCESSORIES

Filtro lunga durata Long life filter CFC0140423

ILLUMINAZIONE LIGHTING

Tipo Type LED 2 x 3 W
 Intensità Intensity 401 LUX
 Temperatura Temperature 3500 K

PERFORMANCE PERFORMANCE

Comandi Controls Pulsantiera Meccanica 3V
 3s Mechanical Push Button
 Portata massima Max airflow 600 m³/h
 Livello sonoro Noise level 68 db(A)
 Assorbimento totale Total absorption 256 W
 Uscita Duct size 150 mm
 Classe energetica Energy class C (A**/E)

Filtro grassi alluminio incluso Grease aluminium Filter included

MODELLI MODELS

TUBE PRO IX/A/43 PRF0080075A
 TUBE PRO BL/A/43 PRF0090719A
 TUBE PRO WH/A/43 PRF0090720A



SCHEDA TECNICA TECHNICAL FEATURES

Misure Size	Ø33 cm
Versione Version	Aspirante Duct out
Finiture Finish	Acciaio inox, bianco Stainless steel, white

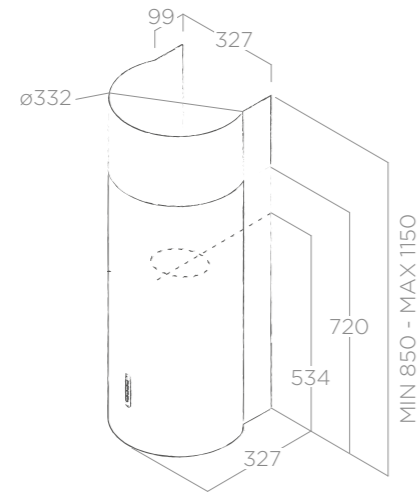

ILLUMINAZIONE LIGHTING

Tipo Type	LED 2 x 2,5 W
Intensità Intensity	141 LUX
Temperatura Temperature	2700 K

PERFORMANCE PERFORMANCE

Comandi Controls	Pulsantiera Soft Light 3V 3S Soft light Push Button
Portata massima max airflow	625 m³/h
Livello sonoro Noise level	70 db(A)
Assorbimento totale Total absorption	180 W
Uscita Duct size	150 mm
Classe energetica Energy class	C (A++/E)

Filtro grassi alluminio incluso Grease aluminium Filter included

ACCESSORI ACCESSORIES

Filtro carbone Charcoal filter	CFC0141529
Filtro lunga durata Long life filter	CFC0141725

MODELLI MODELS

STONE IX/A/33	61412862B
STONE WH/A/33	PRF0007123A

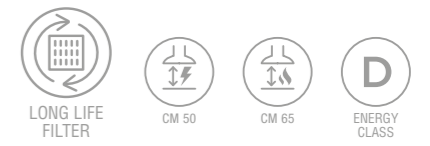

SCHEDA TECNICA TECHNICAL FEATURES

Misure Size	43 - 60 cm
Versione Version	Aspirante Duct out
Finiture Finish	Acciaio Inox Stainless steel

VERSIONE A ISOLA PAG. 79

ISLAND VERSION P. 79

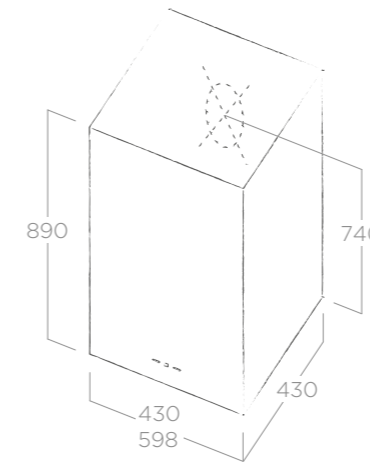

ILLUMINAZIONE LIGHTING

Tipo Type	LED 2 x 2,5 W
Intensità Intensity	101 LUX
Temperatura Temperature	2700 K

PERFORMANCE PERFORMANCE

Comandi Controls	Touch Control con display 3V+I 3S+B Touch Control with display
Portata intensiva Booster airflow	495 m³/h
Livello sonoro Noise level	62 db(A)
Assorbimento totale Total absorption	255 W
Uscita Duct size	150 mm
Classe energetica Energy class	D (A++/E)

Filtro grassi alluminio incluso Grease aluminium Filter included

ACCESSORI ACCESSORIES

Filtro lunga durata Long Life Filter	CFC0140423
--------------------------------------	------------

MODELLI MODELS

KUADRA IX/A/43	PRF0006491A
KUADRA IX/A/60	PRF0007419A





SCHEDA TECNICA TECHNICAL FEATURES

Misure Size	60 - 90 cm
Versione Version	Aspirante Duct out
Finiture Finish	Acciaio inox, nero Stainless steel, black

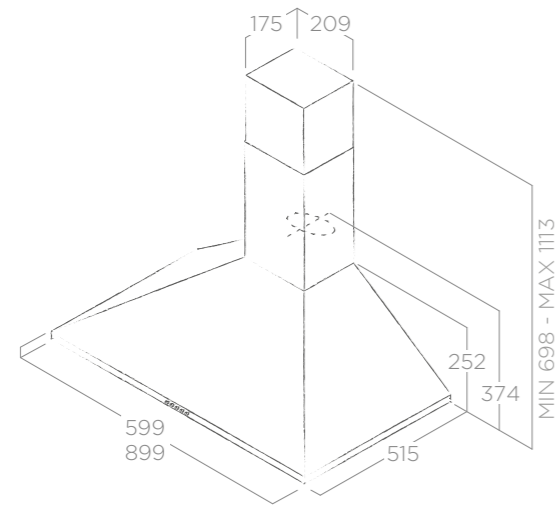

ILLUMINAZIONE LIGHTING

Tipo Type	LED 2 x 3 W
Intensità Intensity	78 LUX
Temperatura Temperature	2700 K

PERFORMANCE PERFORMANCE

Comandi Controls	Pulsantiera Meccanica 3V 3S Mechanical Push Button
Portata massima max airflow	350 m³/h
Livello sonoro Noise level	67 db(A)
Assorbimento totale Total absorption	186 W
Uscita Duct size	120 mm
Classe energetica Energy class	D (A++/E)

Filtro grassi alluminio incluso Grease aluminium Filter included

ACCESSORI ACCESSORIES

Filtro carbone Charcoal filter	CFC0140124
Filtro grassi professionale Professional grease filter	KIT01036
Est. camino Inox Ext. Chimney Inox (+200mm)	KIT00778A
Est. camino Inox Ext. Chimney Inox (+420mm)	KIT00779A

MODELLI MODELS

TAMAYA PB BL/A/60	PRF0009834B
TAMAYA PB BL/A/90	PRF0009854B
TAMAYA PB IX/A/60	PRF0009706B
TAMAYA PB IX/A/90	PRF0009794B



SCHEDA TECNICA TECHNICAL FEATURES

Misure Size	60 - 90 cm
Versione Version	Aspirante Duct out
Finiture Finish	Acciaio inox Stainless steel

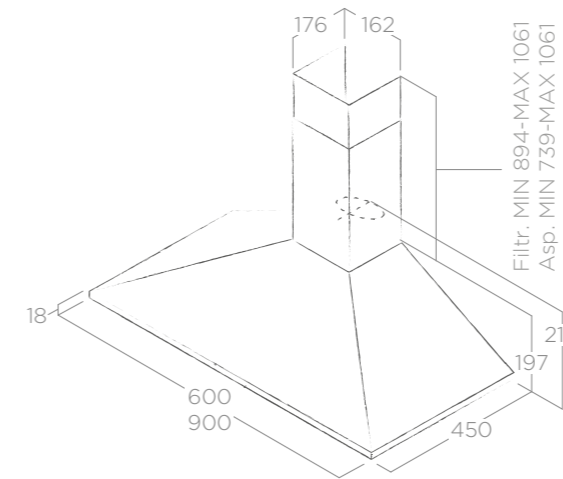

ILLUMINAZIONE LIGHTING

Tipo Type	LED 2 x 3 W
Intensità Intensity	97 LUX
Temperatura Temperature	3700 K

PERFORMANCE PERFORMANCE

Comandi Controls	Slider 3V 3S Slider
Portata massima max airflow	390 m³/h
Livello sonoro Noise level	68 db(A)
Assorbimento totale Total absorption	96 W
Uscita Duct size	150 mm
Classe energetica Energy class	D (A++/E)

Filtro grassi alluminio incluso Grease aluminium Filter included

ACCESSORI ACCESSORIES

Filtro carbone Charcoal Filter	CFC0141497
--------------------------------	------------

MODELLI MODELS

MISSY IX/A/60	PRF0004024C
MISSY IX/A/90	PRF0004022C





SCHEDA TECNICA TECHNICAL FEATURES

Misure Size	60 - 90 cm
Versione Version	Filtrante Recycling
Finiture Finish	Acciaio inox Stainless steel

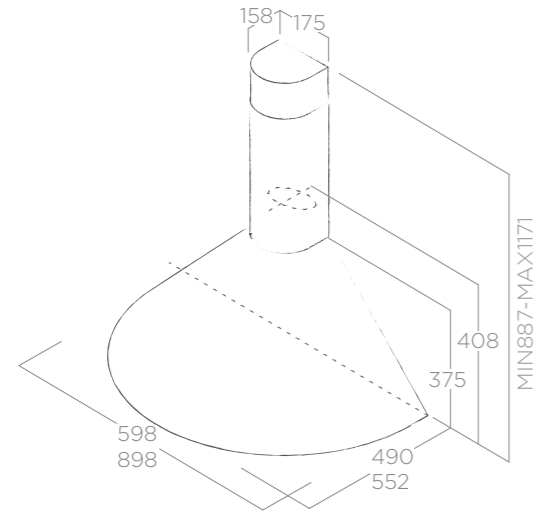

ILLUMINAZIONE LIGHTING

Tipo Type	LED 2 x 3 W
Intensità Intensity	78 LUX
Temperatura Temperature	2700 K

PERFORMANCE PERFORMANCE

Comandi Controls	Slider 3V 3s Slider
Portata massima max airflow	350 m³/h
Livello sonoro Noise level	67 db(A)
Assorbimento totale Total absorption	146 W
Uscita Duct size	120 mm
Classe energetica Energy class	D (A++/E)

Filtro grassi alluminio incluso Grease aluminium Filter included
Filtro carbone incluso Charcoal Filter included

ACCESSORI ACCESSORIES

Filtro carbone Charcoal filter	CFC0140124
--------------------------------	------------

MODELLI MODELS

TONDA IX F/60	2938000C
TONDA IX F/90	2937999C



SCHEDA TECNICA TECHNICAL FEATURES

Misure Size	60 - 90 cm
Versione Version	Filtrante Recycling
Finiture Finish	Acciaio Inox Stainless steel

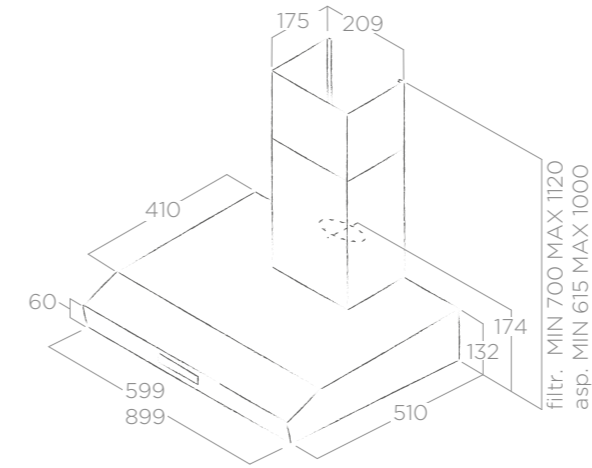

ILLUMINAZIONE LIGHTING

Tipo Type	LED 2 x 3 W
Intensità Intensity	85 LUX
Temperatura Temperature	3500 K

PERFORMANCE PERFORMANCE

Comandi Controls	Slider 3V 3s Slider
Portata massima max airflow	272 m³/h
Livello sonoro Noise level	71 db(A)
Assorbimento totale Total absorption	121 W
Uscita Duct size	120 mm
Classe energetica Energy class	D (A++/E)

Filtro grassi alluminio incluso Grease aluminium Filter included
Filtro carbone incluso Charcoal Filter included

ACCESSORI ACCESSORIES

Filtro carbone Charcoal Filter	CFC0140064
Kit camino Chimney Kit (+200mm)	KIT00778A
Kit camino Chimney Kit (+420mm)	KIT00779A

MODELLI MODELS

VEGA ST IX/F/60	56111002C
VEGA ST IX/F/90	56111004B





CORNER
MOUNTED

ACUTA
ELICA DESIGN CENTER

A
ENERGY
CLASS

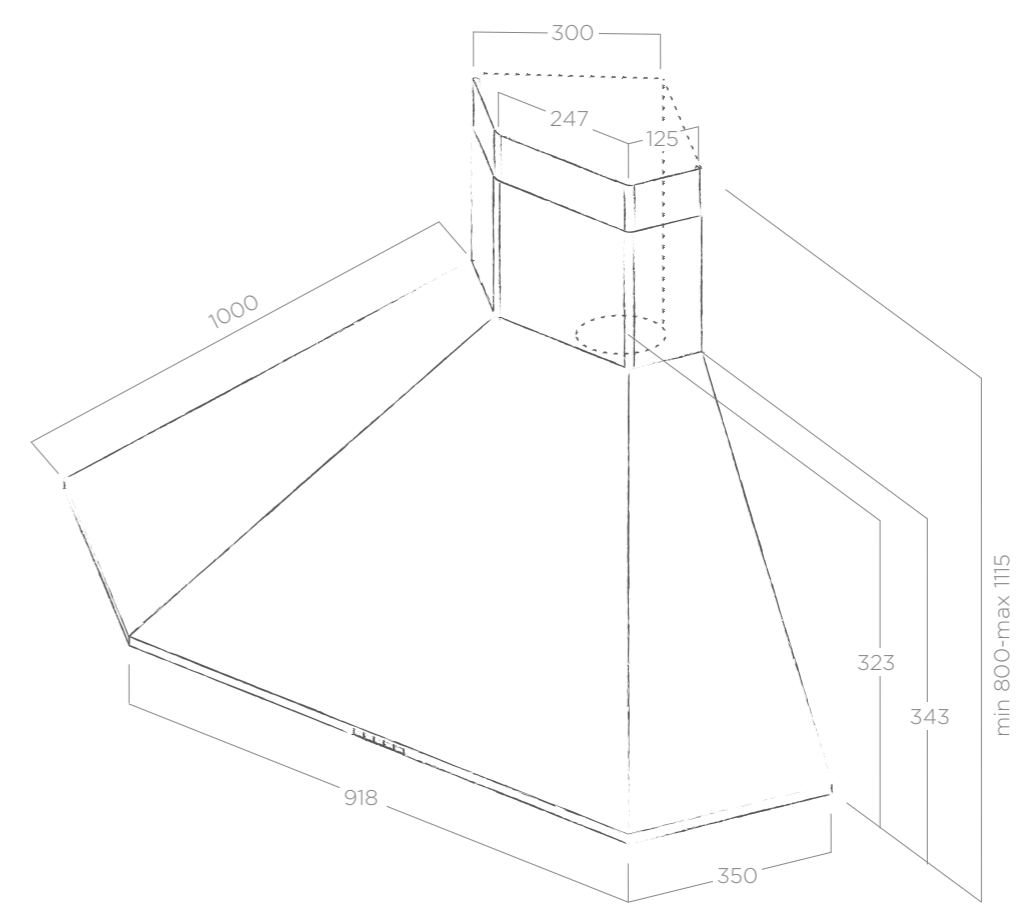

SCHEDA TECNICA TECHNICAL FEATURES

Misure Size	100 cm
Versione Version	Filtrante Recycling
Finiture Finish	Acciaio inox, nero Stainless steel, black

ACCESSORI ACCESSORIES	
Filtro carbone Charcoal Filter	CFC0140343

ILLUMINAZIONE LIGHTING	
Tipo Type	LED 4 x 2,5 W
Intensità Intensity	141 LUX
Temperatura Temperature	3500 K

PERFORMANCE PERFORMANCE	
Comandi Controls	Touch Control 3V+I 3S+B Touch Control
Portata intensiva Booster airflow	625 m ³ /h
Livello sonoro Noise level	60 db(A)
Assorbimento totale Total absorption	210 W
Uscita Duct size	150 mm
Classe energetica Energy class	A (A**/E)

Filtro grassi alluminio incluso Grease aluminium Filter included	
Filtro carbone incluso Charcoal Filter included	

MODELLI MODELS	
ACUTA IX/F/100	PRF0121267A
ACUTA BL/F/100	PRF0127462A



SCHEDA TECNICA TECHNICAL FEATURES

Misure Size	100 cm
Versione Version	Filtrante Recycling
Finiture Finish	Acciaio inox Stainless steel

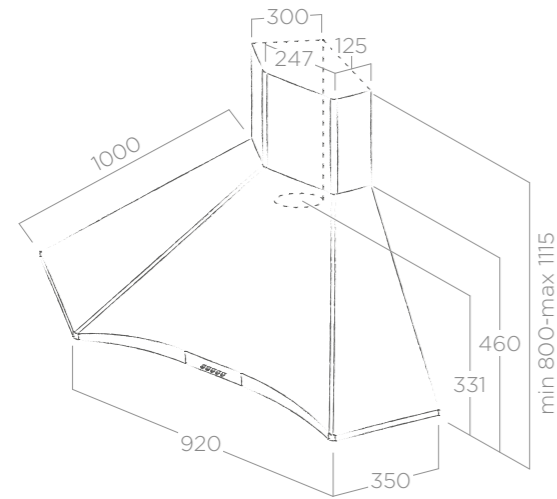

ILLUMINAZIONE LIGHTING

Tipo Type	LED 2 x 2,5 W
Intensità Intensity	141 LUX
Temperatura Temperature	3500 K

PERFORMANCE PERFORMANCE

Comandi Controls	Pulsantiera Meccanica 3V 3S Mechanical Push Button
Portata massima max airflow	495 m³/h
Livello sonoro Noise level	68 db(A)
Assorbimento totale Total absorption	170 W
Uscita Duct size	150 mm
Classe energetica Energy class	C (A++/E)

Filtro grassi alluminio incluso Grease aluminium Filter included
Filtro carbone incluso Charcoal Filter included

ACCESSORI ACCESSORIES

Filtro carbone Charcoal filter	CFC0140122
Filtro grassi inox professionale Professional stainless steel grease filter	KIT01036

MODELLI MODELS

HYDRA ANG IX F/100	1608046A
--------------------	----------



SCHEDA TECNICA TECHNICAL FEATURES

Misure Size	100 cm
Versione Version	Aspirante Duct out
Finiture Finish	Acciaio Inox + vetro Stainless steel + glass

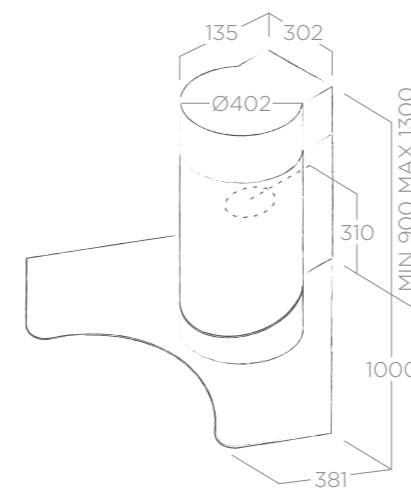

ILLUMINAZIONE LIGHTING

Tipo Type	LED 2 x 2,5 W
Intensità Intensity	141 LUX
Temperatura Temperature	3500 K

PERFORMANCE PERFORMANCE

Comandi Controls	Pulsantiera Soft Light 3V 3S Soft Light Push Button
Portata massima max airflow	545 m³/h
Livello sonoro Noise level	67 db(A)
Assorbimento totale Total absorption	180 W
Uscita Duct size	150 mm
Classe energetica Energy class	C (A++/E)

Filtro grassi alluminio incluso Grease aluminium Filter included

ACCESSORI ACCESSORIES

Filtro carbone Charcoal Filter	CFC0141529
Filtro lunga durata Long Life Filter	CFC0141725

MODELLI MODELS

PERSONAL VT+ IX/A/100	66414789A
-----------------------	-----------



SYNTHESIS

ELICA DESIGN CENTER



SCHEDA TECNICA TECHNICAL FEATURES

Misure Size	100 cm
Versione Version	Aspirante Duct out
Finiture Finish	Acciaio inox + vetro Stainless steel + glass

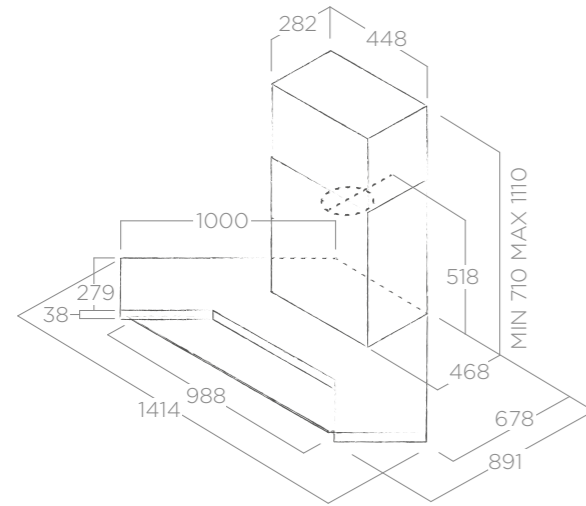

ILLUMINAZIONE LIGHTING

Tipo Type	LED 4 x 2,5
Intensità Intensity	201 LUX
Temperatura Temperature	3500 K

PERFORMANCE PERFORMANCE

Comandi Controls	Control Ball 3V+I 3S+B Control Ball
Portata intensiva Booster airflow	555 m³/h
Livello sonoro Noise level	63 db(A)
Assorbimento totale Total absorption	185 W
Uscita Duct size	150 mm
Classe energetica Energy class	C (A++/E)

Filtro grassi alluminio incluso Grease aluminium Filter included

ACCESSORI ACCESSORIES

Filtro carbone Charcoal filter	CFC0141529
Filtro lunga durata Long Life Filter	CFC0141725

MODELLI MODELS

SYNTHESIS IX A/100	64214507A
--------------------	-----------

RUBINO CORNER

ELICA DESIGN CENTER



SCHEDA TECNICA TECHNICAL FEATURES

Misure Size	100 cm
Versione Version	Aspirante Duct out
Finiture Finish	Acciaio Inox Stainless steel

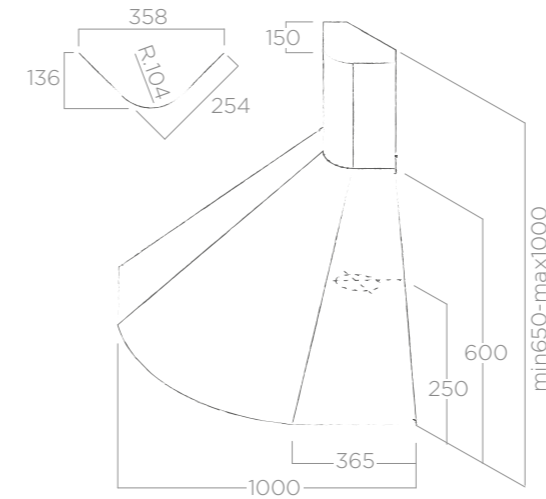

ILLUMINAZIONE LIGHTING

Tipo Type	LED 2 x 3 W
Intensità Intensity	121 LUX
Temperatura Temperature	3700 K

PERFORMANCE PERFORMANCE

Comandi Controls	Slider 3V 3S Slider
Portata massima max airflow	600 m³/h
Livello sonoro Noise level	64 db(A)
Assorbimento totale Total absorption	186 W
Uscita Duct size	150 mm
Classe energetica Energy class	C (A++/E)

Filtro grassi alluminio incluso Grease aluminium Filter included

ACCESSORI ACCESSORIES

Filtro carbone Charcoal Filter	CFC0140124
--------------------------------	------------

MODELLI MODELS

RUBINO ANG IX A/100 IX	56811101C
------------------------	-----------



ISLAND

Lontano dalla frenetica velocità della vita, ci sono isole che ci regalano la loro calda accoglienza. Comfort ed eleganza minimal: è casa, è cucina, è Joy Island.

Far from the hectic pace of life, there are islands that offer a warm welcome. Comfort and minimalist elegance: it is home, it is the kitchen, it is Joy Island.



JOY ISLAND





JOY ISLAND

ELICA DESIGN CENTER

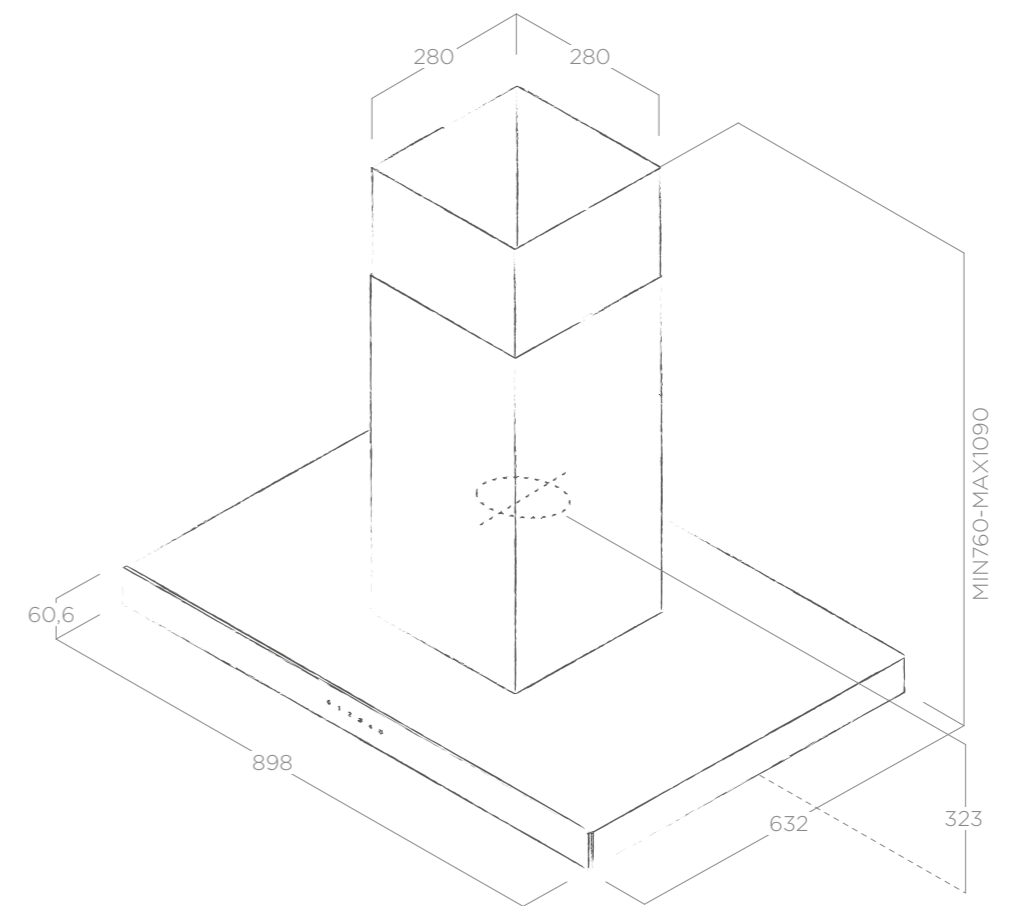

LONG LIFE FILTER

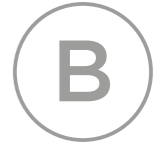

ENERGY CLASS

ISLAND



CM 50



CM 65

VERSIONE A PARETE PAG. 38

WALL VERSION P. 38

SCHEDA TECNICA TECHNICAL FEATURES

Misure Size	90x60 cm
Versione Version	Aspirante Duct-out
Finiture Finish	Acciaio inox + vetro nero, acciaio inox + vetro bianco Stainless steel + black glass, stainless steel + white glass

ACCESSORI ACCESSORIES

Filtro carbone Charcoal Filter	CFC0141529
Filtro lunga durata Long Life Filter	CFC0141725

ILLUMINAZIONE LIGHTING

Tipo Type	LED 4 x 2,5 W
Intensità Intensity	281 LUX
Temperatura Temperature	3500 K

PERFORMANCE PERFORMANCE

Comandi Controls	Touch Control 3V+I 3S+ B Touch Control
Portata intensiva Booster airflow	710 m ³ /h
Livello sonoro Noise level	69 db(A)
Assorbimento totale Total absorption	270 W
Uscita Duct size	150 mm
Classe energetica Energy class	B (A ⁺⁺ /E)

MODELLI MODELS

JOY ISLAND BLIX/A/90	PRF0104628A
JOY ISLAND WHIX/A/90	PRF0104629A

Filtro grassi alluminio incluso Grease aluminium Filter included



SPOT PLUS ISLAND

ELICA DESIGN CENTER

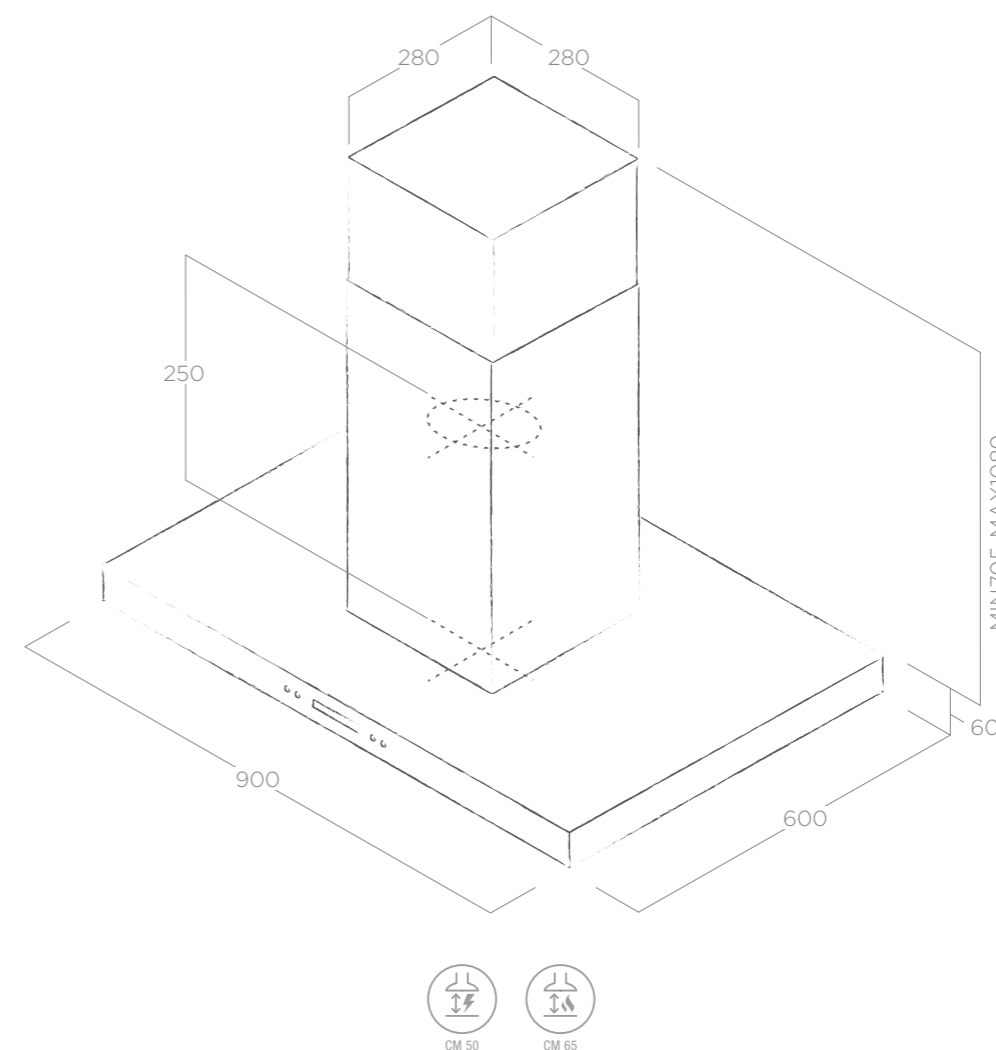

LONG LIFE FILTER



ENERGY CLASS

ISLAND

VERSIONE A PARETE PAG. 36

WALL VERSION P. 36

SCHEDA TECNICA TECHNICAL FEATURES

Misure Size 90x60 cm
 Versione Version Aspirante Duct-out
 Finiture Finish Acciaio inox
 Stainless steel

ACCESSORI ACCESSORIES

Filtro carbone Charcoal Filter CFC0141529
 Filtro lunga durata Long Life Filter CFC0141725

ILLUMINAZIONE LIGHTING

Tipo Type LED 4 x 2,5 W
 Intensità Intensity 410 LUX
 Temperatura Temperature 4000 K

PERFORMANCE PERFORMANCE

Comandi Controls LCD 3V+I
 3S+B LCD
 Portata intensiva Booster airflow 600 m³/h
 Livello sonoro Noise level 64 db(A)
 Assorbimento totale Total absorption 270 W
 Uscita Duct size 150 mm
 Classe energetica Energy class A (A**/E)

MODELLI MODELS

Filtro grassi alluminio incluso Grease aluminium Filter included

SPOT PLUS ISLAND IX/A/90

PRF0097375



FLAT GLASS PLUS ISLAND

ELICA DESIGN CENTER



SCHEDA TECNICA TECHNICAL FEATURES

Misure Size	90x60 cm
Versione Version	Aspirante Duct out
Finiture Finish	Acciaio inox + vetro Stainless steel + glass

VERSIONE A PARETE PAG. 43

WALL VERSION P. 43

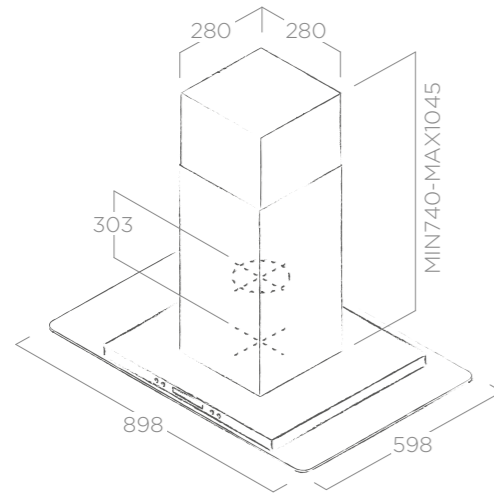

ILLUMINAZIONE LIGHTING

Tipo Type	LED 2 x 2,5 W
Intensità Intensity	145 LUX
Temperatura Temperature	4000 K

PERFORMANCE PERFORMANCE

Comandi Controls	LCD 3V+I 3S+B LCD
Portata intensiva Booster airflow	600 m³/h
Livello sonoro Noise level	62 db(A)
Assorbimento totale Total absorption	265 W
Uscita Duct size	150 mm
Classe energetica Energy class	A (A**/E)

Filtro grassi alluminio incluso Grease aluminium Filter included

ACCESSORI ACCESSORIES

Filtro carbone Charcoal filter	CFC0141529
Filtro lunga durata Long Life Filter	CFC0141725

MODELLI MODELS

FLAT GLASS ISLAND PLUS IX/A/90	PRF0097369
--------------------------------	------------

TRIBE ISLAND

ELICA DESIGN CENTER

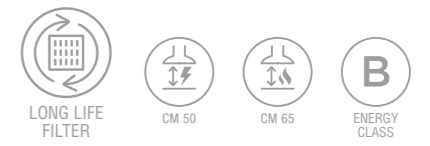

SCHEDA TECNICA TECHNICAL FEATURES

Misure Size	90x60 cm
Versione Version	Aspirante Duct out
Finiture Finish	Acciaio inox + vetro Stainless steel + glass

VERSIONE A PARETE PAG. 44

WALL VERSION P. 44

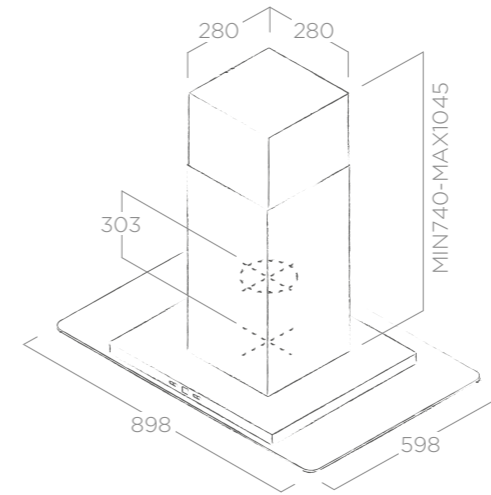

ILLUMINAZIONE LIGHTING

Tipo Type	LED 2 x 2,5 W
Intensità Intensity	145 LUX
Temperatura Temperature	3500 K

PERFORMANCE PERFORMANCE

Comandi Controls	Touch Control con display 3V+I 3S+B Touch Control with display
Portata intensiva Booster airflow	710 m³/h
Livello sonoro Noise level	68 db(A)
Assorbimento totale Total absorption	265 W
Uscita Duct size	150 mm
Classe energetica Energy class	B (A**/E)

Filtro grassi alluminio incluso Grease aluminium Filter included

ACCESSORI ACCESSORIES

Filtro carbone Charcoal Filter	CFC0141529
Filtro lunga durata Long Life Filter	CFC0141725

MODELLI MODELS

TRIBE ISLAND IX/A/90X60	PRF0049160B
-------------------------	-------------



CIRCUS PLUS ISLAND

ELICA DESIGN CENTER



SCHEDA TECNICA TECHNICAL FEATURES

Misure Size	90x60 cm
Versione Version	Aspirante Duct out
Finiture Finish	Acciaio inox + vetro Stainless steel + glass

VERSIONE A PARETE PAG. 49

WALL VERSION P. 49

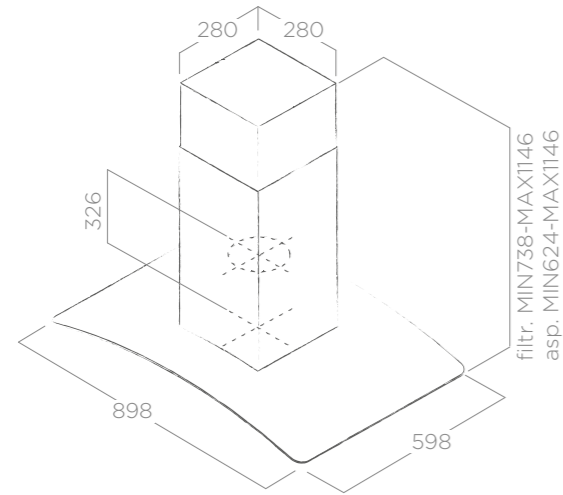

ILLUMINAZIONE LIGHTING

Tipo Type	LED 2 x 2,5 W
Intensità Intensity	145 LUX
Temperatura Temperature	4000 K

PERFORMANCE PERFORMANCE

Comandi Controls	LCD 3V + I 3S + B LCD
Portata intensiva Booster airflow	600 m³/h
Livello sonoro Noise level	62 db(A)
Assorbimento totale Total absorption	265 W
Uscita Duct size	150 mm
Classe energetica Energy class	A (A**/E)

Filtro grassi alluminio incluso Grease aluminium Filter included

ACCESSORI ACCESSORIES

Filtro carbone Charcoal filter	CFC0141529
Filtro lunga durata Long Life Filter	CFC0141725

MODELLI MODELS

CIRCUS PLUS ISLAND IX/A/90	PRF0097370
----------------------------	------------

REEF ISLAND

ELICA DESIGN CENTER

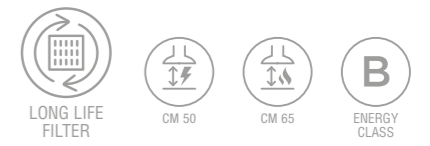

SCHEDA TECNICA TECHNICAL FEATURES

Misure Size	90x60 cm
Versione Version	Aspirante Duct out
Finiture Finish	Acciaio inox + vetro Stainless steel + glass

VERSIONE A PARETE PAG. 50

WALL VERSION P. 50

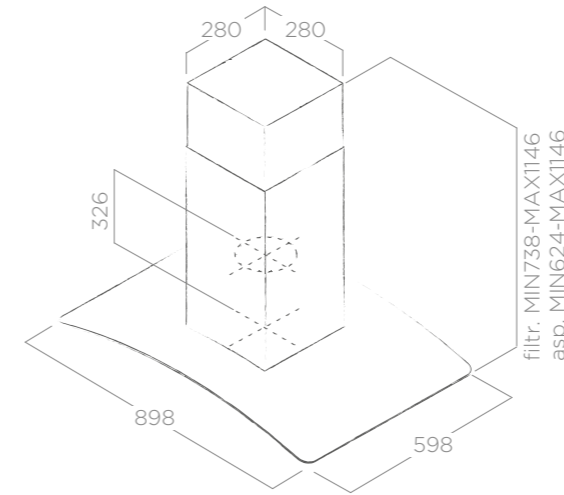

ILLUMINAZIONE LIGHTING

Tipo Type	LED 2 x 2,5 W
Intensità Intensity	145 LUX
Temperatura Temperature	3500 K

PERFORMANCE PERFORMANCE

Comandi Controls	Touch Control con display 3V + I 3S + B Touch Control with display
Portata intensiva Booster airflow	710 m³/h
Livello sonoro Noise level	68 db(A)
Assorbimento totale Total absorption	265 W
Uscita Duct size	150 mm
Classe energetica Energy class	B (A**/E)

Filtro grassi alluminio incluso Grease aluminium Filter included

ACCESSORI ACCESSORIES

Filtro carbone Charcoal Filter	CFC0141529
Filtro lunga durata Long Life Filter	CFC0141725

MODELLI MODELS

REEF ISLAND IX/A/90X60	PRF0048780B
------------------------	-------------



TUBE PRO ISLAND

ELICA DESIGN CENTER



SCHEDA TECNICA TECHNICAL FEATURES

Misure Size	Ø43 cm
Versione Version	Aspirante Duct out
Finiture Finish	Acciaio inox, nero, bianco Stainless steel, black, white

VERSIONE A PARETE PAG. 53

WALL VERSION P. 53

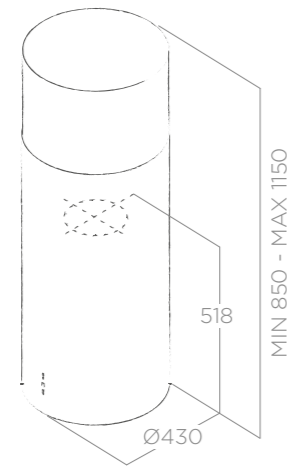

ILLUMINAZIONE LIGHTING

Tipo Type	LED 2 X 3 W
Intensità Intensity	401 LUX
Temperatura Temperature	3500 K

PERFORMANCE PERFORMANCE

Comandi Controls	Pulsantiera Meccanica 3V 3s mechanical Push Button
Portata massima Max airflow	600 m³/h
Livello sonoro Noise level	68 db(A)
Assorbimento totale Total absorption	256 W
Uscita Duct size	150 mm
Classe energetica Energy class	C (A++/E)

Filtro grassi alluminio incluso Grease aluminium Filter included

ACCESSORI ACCESSORIES

Filtro lunga durata Long Life Filter	CFC0140423
--------------------------------------	------------

MODELLI MODELS

TUBE PRO ISLAND IX/A/43	PRF0044794A
TUBE PRO ISLAND BL/A/43	PRF0090717A
TUBE PRO ISLAND WH/A/43	PRF0090718A

KUADRA ISLAND

ELICA DESIGN CENTER



SCHEDA TECNICA TECHNICAL FEATURES

Misure Size	43x43 - 60x43 cm
Versione Version	Aspirante Duct out
Finiture Finish	Acciaio inox Stainless steel

VERSIONE A PARETE PAG. 55

WALL VERSION P. 55

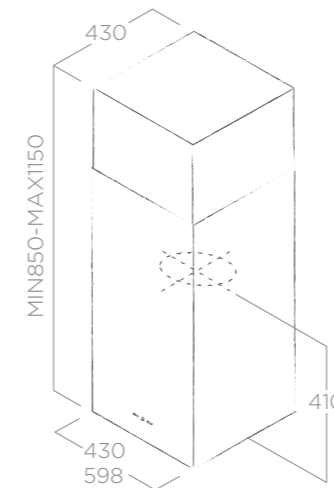

ILLUMINAZIONE LIGHTING

Tipo Type	LED 2 x 2,5 W
Intensità Intensity	101 LUX
Temperatura Temperature	2700 K

PERFORMANCE PERFORMANCE

Comandi Controls	Touch Control con display 3V+I 3S+B Touch Control with display
Portata intensiva booster airflow	495 m³/h
Livello sonoro Noise level	62 db(A)
Assorbimento totale Total absorption	255 W
Uscita Duct size	150 mm
Classe energetica Energy class	D (A++/E)

Filtro grassi alluminio incluso Grease aluminium Filter included

ACCESSORI ACCESSORIES

Filtro lunga durata Long Life Filter	CFC0140423
--------------------------------------	------------

MODELLI MODELS

KUADRA ISLAND IX/A/43	PRF0007655A
KUADRA ISLAND IX/A/60	PRF0007028A



CEILING

Le Ceiling sono sofisticate come solo il design ispirato dalla leggerezza sa essere.
Cloud Seven è eleganza e linearità allo stato puro.

Ceiling hoods are sophisticated, as only design inspired by lightness can be.
Cloud Seven is elegance and linearity in the purest form.

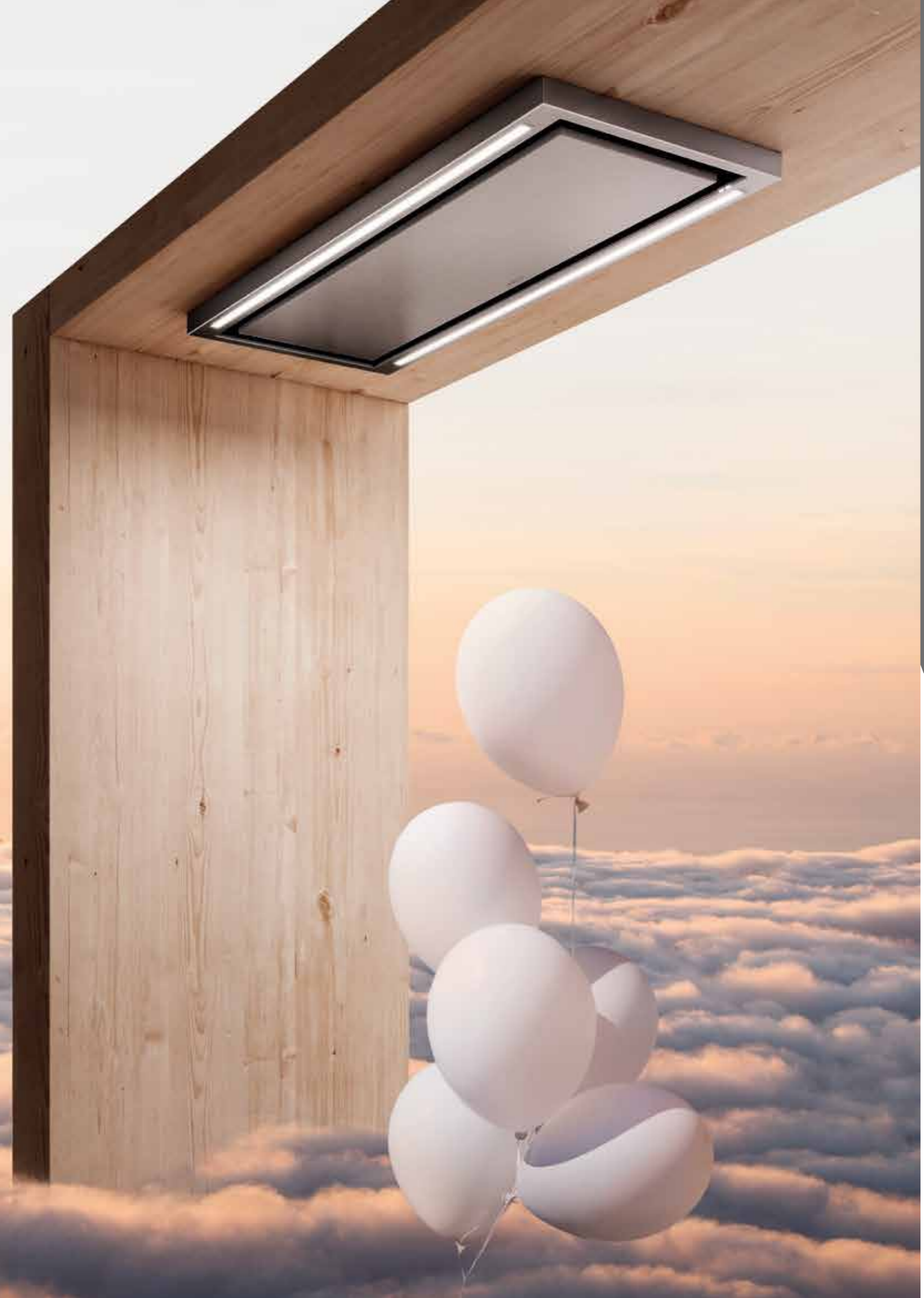

CLOUD SEVEN

DESIGN FABRIZIO CRISÀ



CLOUD SEVEN

DESIGN FABRIZIO CRISÀ

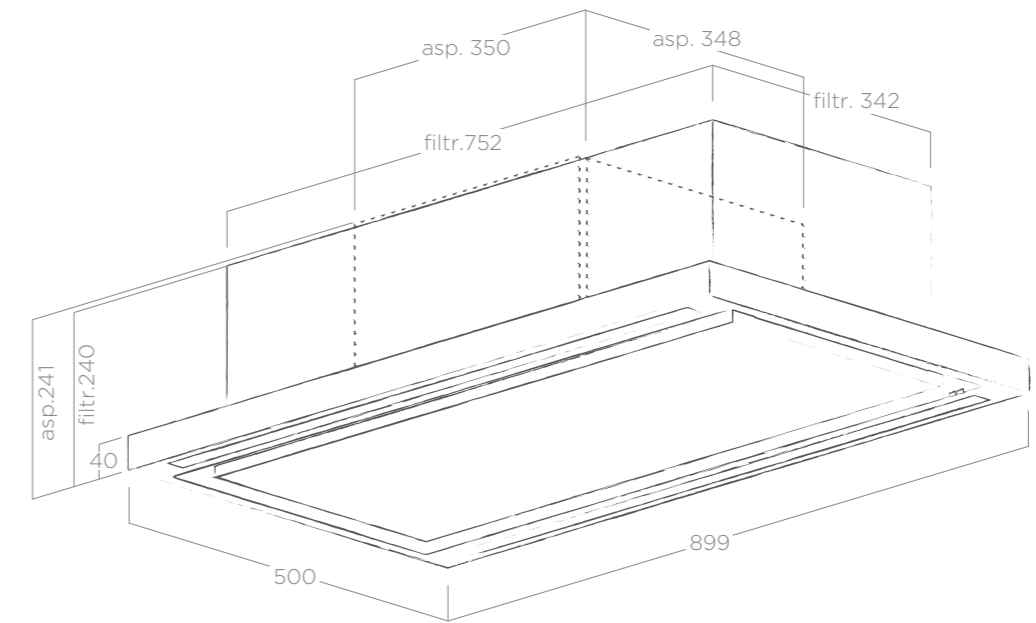

FALSE CEILING CUT: 480X880



SMART
INSTALLATION



ENERGY
CLASS



KG 16,1



KG 18,4*

SCHEDA TECNICA TECHNICAL FEATURES

Misure Size	90 cm
Versione Version	Aspirante/filtrante Duct-out/recycling
Finiture Finish	Acciaio inox Stainless steel

ILLUMINAZIONE LIGHTING

Tipo Type	STRIP LED 2 X 7 W
Intensità Intensity	393 LUX
Temperatura Temperature	3500 K

PERFORMANCE PERFORMANCE

Comandi Controls	Radiocomando	(*) Radiocomando
	3V+2I 3S+2B Remote Control	3V+I 3S+B Remote Control
Portata intensiva Booster airflow	760 m ³ /h	550 m ³ /h
Livello sonoro Noise level	61 db(A)	71 db(A)
Assorbimento totale Total absorption	174 W	214 W
Uscita Duct size	150 mm	N/A
Classe energetica Energy class	A++ (A+/E)	N/A

Filtro grassi alluminio incluso Grease aluminium filter included
Filtro carbone incluso* Charcoal filter included*

ACCESSORI ACCESSORIES

Filtro lunga durata Long Life Filter	CFC0140426
Radiocomando bianco White remote control	KIT0121468
Radiocomando nero Black remote control	KIT0121469



Radiocomando incluso. Estetiche a pag. 117
Kit remote control included. See page 117 for available design.
Modello non soggetto a certificazione energetica obbligatoria.*
Model not subject to compulsory energy certification.*



CORPO CAPPA BIANCO VERNICIABILE
PAINTABLE WHITE HOOD STRUCTURE

MODELLI MODELS

CLOUD SEVEN IX/A/90	PRF0142094
CLOUD SEVEN IX/F/90 (*)	PRF0141953



SUSPENDED

Ceci n'est pas un lustre, questo non è un lampadario. Le sospese sono eleganti oggetti di design e cappe multifunzionali. Juno è il modello più ricercato, nelle versioni nero, bianco e acciaio inox.

Ceci n'est pas un lustre, this is no lamp. Suspended hoods are elegant design objects and multi-functional hoods. Juno is the most popular design. It comes in black, white and stainless steel.

JUNO





JUNO URBAN

ELICA DESIGN CENTER

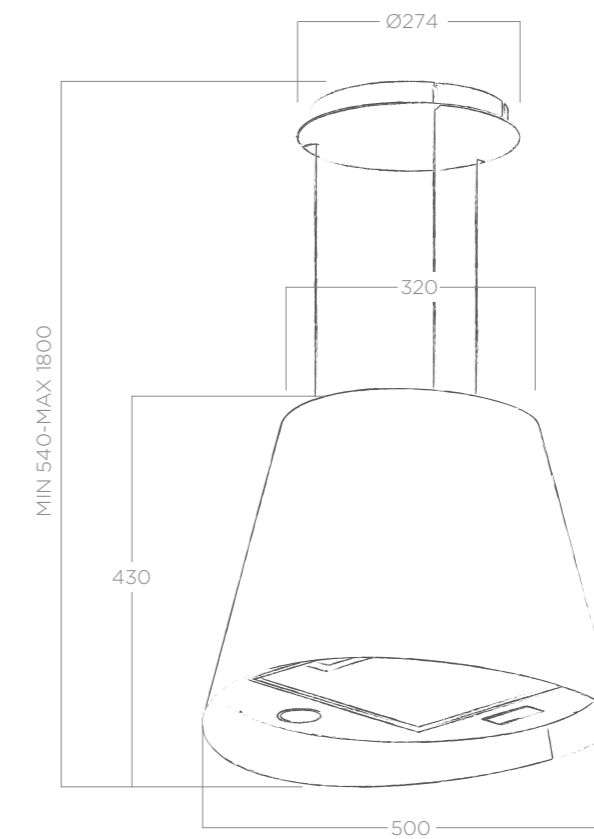

LONG LIFE
FILTER



ENERGY
CLASS

SCHEDA TECNICA TECHNICAL FEATURES

Misure Size	Ø 50 cm
Versione Version	Filtrante Recycling
Finiture Finish	Effetto ghisa - Effetto zincato Cast iron effect - Zinc coating effect

ILLUMINAZIONE LIGHTING

Tipo Type	LED 2 X 2,5 W
Intensità Intensity	140 LUX
Temperatura Temperature	3500 K

PERFORMANCE PERFORMANCE

Comandi Controls	Pulsantiera Soft Light 3V 3S Soft Light Push Button
Portata massima Max airflow	600 m ³ /h
Livello sonoro Noise level	67 db(A)
Assorbimento totale Total absorption	250 W
Uscita Duct size	150 mm
Classe energetica Energy class	A (A**/E)

Filtro grassi alluminio incluso Grease aluminium filter included
Filtro lunga durata incluso Long Life filter included

ACCESSORI ACCESSORIES

Filtro lunga durata Long Life Filter	CFC0140088
Kit installazione a parete wall mounted kit	KIT02263
Kit prolunga cavi (2,5m) Extension cable kit (2,5m)	KIT01889
Kit prolunga cavi (5m) Extension cable kit (5m)	KIT01921

MODELLI MODELS

JUNO URBAN CAST IRON/F/50	PRF0147728
JUNO URBAN ZINC/F/50	PRF0147730



SCHEDA TECNICA TECHNICAL FEATURES

Misure Size	Ø 50 cm
Versione Version	Filtrante Recycling
Finiture Finish	Acciaio inox, bianco, nero Stainless steel, white, black

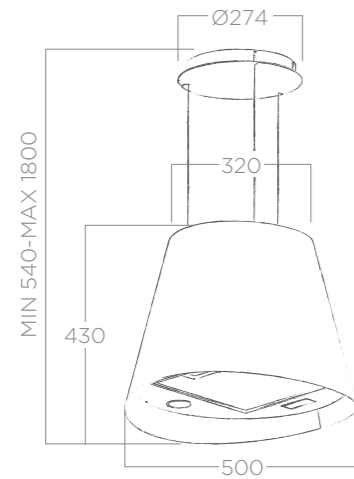

ILLUMINAZIONE LIGHTING

Tipo Type	LED 2 X 2,5 W
Intensità Intensity	140 LUX
Temperatura Temperature	3500 K

PERFORMANCE PERFORMANCE

Comandi Controls	Pulsantiera Soft Light 3V 3S Soft Light Push Button
Portata massima Max airflow	600 m³/h
Livello sonoro Noise level	67 db(A)
Assorbimento totale Total absorption	250 W
Uscita Duct size	150 mm
Classe energetica Energy class	A (A**/E)

Filtro grassi alluminio incluso Grease aluminium filter included
Filtro lunga durata incluso Long Life filter included

ACCESSORI ACCESSORIES

Filtro lunga durata Long Life Filter	CFC0140088
Kit installazione a parete wall mounted kit	KIT02263
Kit prolunga cavi (2,5m) Extension cable kit (2,5m)	KIT01889
Kit prolunga cavi (5m) Extension cable kit (5m)	KIT01921

MODELLI MODELS

JUNO IX/F/50	PRF0089651B
JUNO WH/F/50	PRF0071972B
JUNO BL/F/50	PRF0071970B



SCHEDA TECNICA TECHNICAL FEATURES

Misure Size	Ø 25 cm
Versione Version	Filtrante Recycling
Finiture Finish	Acciaio inox Stainless steel

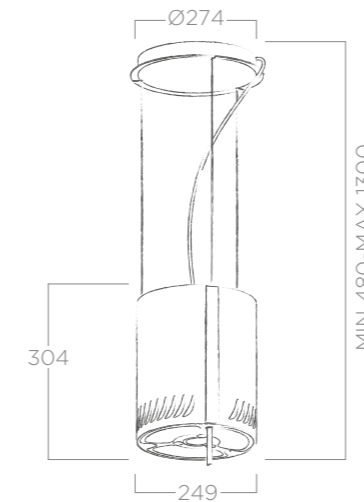

ILLUMINAZIONE LIGHTING

Tipo Type	LED 1 X 5 W
Intensità Intensity	145 LUX
Temperatura Temperature	4000 K

PERFORMANCE PERFORMANCE

Comandi Controls	Magic Wand 3V+I 3S+B Magic Wand
Portata intensiva Booster airflow	515 m³/h
Livello sonoro Noise level	66 db(A)
Assorbimento totale Total absorption	225 W
Uscita Duct size	150 mm
Classe energetica Energy class	B (A**/E)

Filtro grassi alluminio incluso Grease aluminium filter included
Filtro lunga durata incluso Long Life filter included

ACCESSORI ACCESSORIES

Filtro lunga durata Long Life Filter	CFC0140384
Kit prolunga cavi (2,5m) Extension cable kit (2,5m)	KIT01889
Kit prolunga cavi (5m) Extension cable kit (5m)	KIT01921
Radiocomando bianco White remote control	KIT0121468
Radiocomando nero Black remote control	KIT0121469



Radiocomando a richiesta. Estetiche disponibili a pag. 117
Kit remote control optional. See page 117 for available design.

MODELLI MODELS

NAKED IX/F/25	64714985/1
---------------	------------



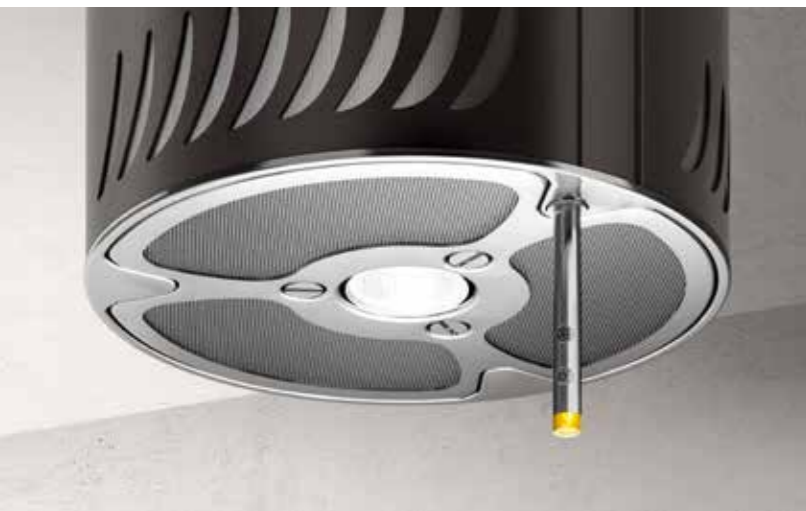

NAKED URBAN

ELICA DESIGN CENTER

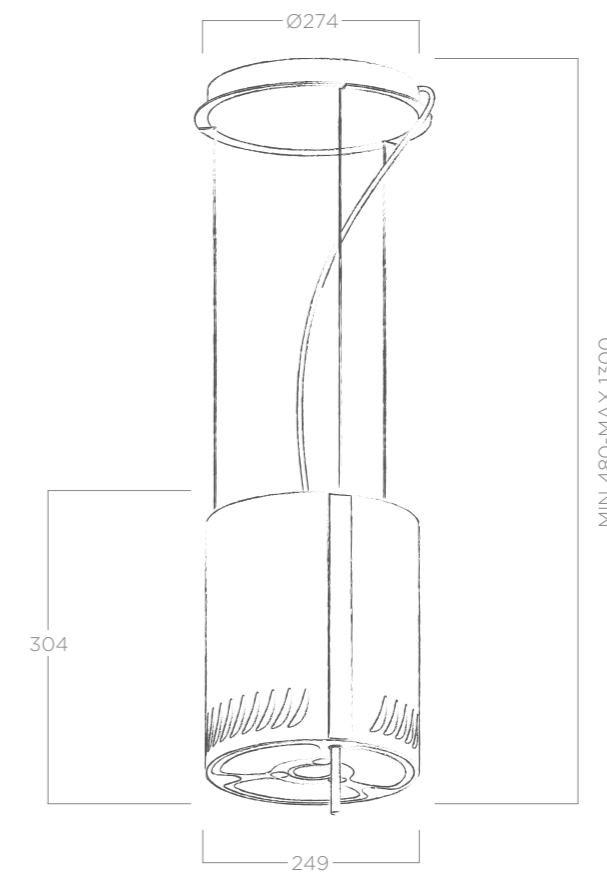

LONG LIFE FILTER



ENERGY CLASS

SCHEDA TECNICA TECHNICAL FEATURES

Misure Size	Ø 25 cm
Versione Version	Filtrante Recycling
Finiture Finish	Effetto ghisa - Effetto zincato Cast iron effect - Zinc coating effect

ILLUMINAZIONE LIGHTING

Tipo Type	LED 1 X 5 W
Intensità Intensity	145 LUX
Temperatura Temperature	4000 K

PERFORMANCE PERFORMANCE

Comandi Controls	Magic Wand 3V+I 3S+B Magic Wand
Portata intensiva Booster airflow	515 m ³ /h
Livello sonoro Noise level	66 db(A)
Assorbimento totale Total absorption	225 W
Uscita Duct size	150 mm
Classe energetica Energy class	B (A**/E)

ACCESSORI ACCESSORIES

Filtro lunga durata Long Life Filter	CFC0140384
Kit prolunga cavi (2,5m) Extension cable kit (2,5m)	KIT01889
Kit prolunga cavi (5m) Extension cable kit (5m)	KIT01921
Radiocomando bianco White remote control	KIT0121468
Radiocomando nero Black remote control	KIT0121469



Radiocomando a richiesta. Estetiche disponibili a pag. 117
Kit remote control optional. See page 117 for available design.

MODELLI MODELS

NAKED URBAN CAST IRON/F/25	PRF0147733
NAKED URBAN ZINC/F/25	PRF0147734

Filtro grassi alluminio incluso Grease aluminium filter included
Filtro lunga durata incluso Long Life filter included



BUILT-IN

C'è una bellezza visibile agli occhi. E ce n'è una invisibile, nascosta e silenziosa, che cattura nel momento esatto della sua scomparsa. Come il fascino della cappa a incasso Era.

There is beauty visible to the eye. And there is invisible beauty, hidden and quiet, that you only realise at the precise moment of its disappearance. Like the charm of the Era built-in hood.



ERA S

DESIGN FABRIZIO CRISÀ



ERA S

ELICA DESIGN CENTER

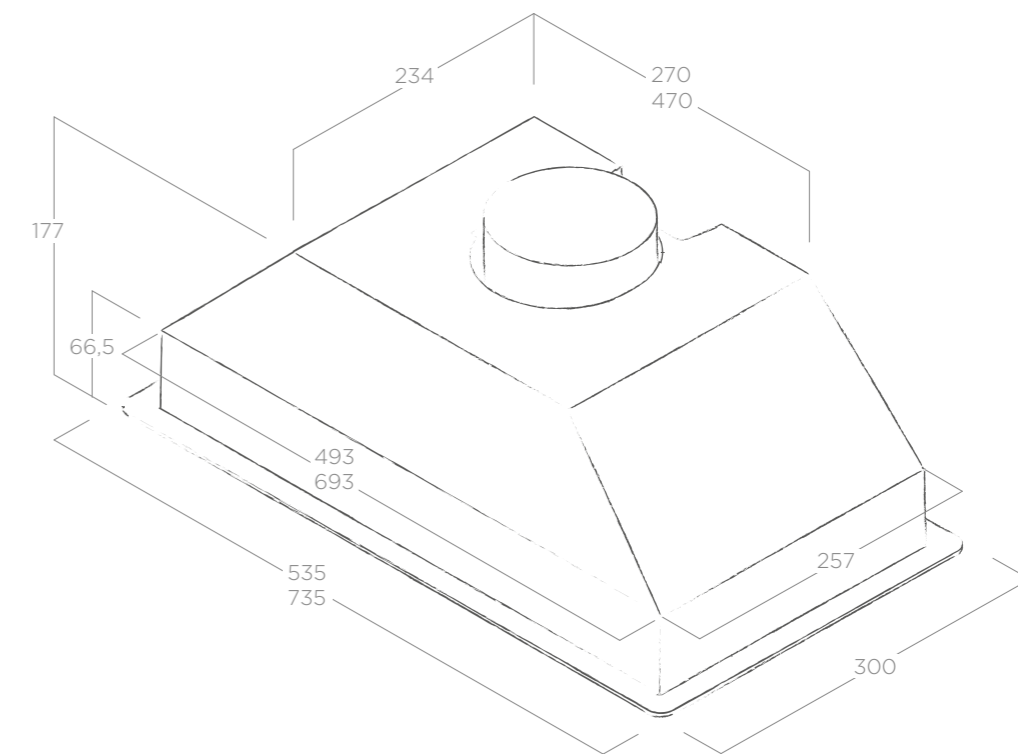

SMART
INSTALLATION



ENERGY
CLASS



CM 50



CM 65

SCHEDA TECNICA TECHNICAL FEATURES

Misure Size	60 - 80 cm
Versione Version	Aspirante Duct-out
Finiture Finish	Acciaio inox Stainless steel

ACCESSORI ACCESSORIES	
Filtro carbone Charcoal Filter	CFC0141571

ILLUMINAZIONE LIGHTING	
Tipo Type	LED 3 W
Intensità Intensity	73 LUX
Temperatura Temperature	2700 K

PERFORMANCE PERFORMANCE	
Comandi Controls	Rotativo 3V 3S Rotative
Portata massima Max airflow	420 m ³ /h
Livello sonoro Noise level	68 db(A)
Assorbimento totale Total absorption	121 W
Uscita Duct size	120 mm
Classe energetica Energy class	B (A ⁺⁺ /E)

Filtro grassi alluminio incluso Grease aluminium filter included

MODELLI MODELS	
ERA S IX/A/60	PRF0142886
ERA S IX/A/80	PRF0142744



SCHEDA TECNICA TECHNICAL FEATURES

Misure Size	60 - 80 cm
Versione Version	Aspirante Duct-out
Finiture Finish	Acciaio inox, bianco Stainless steel, white

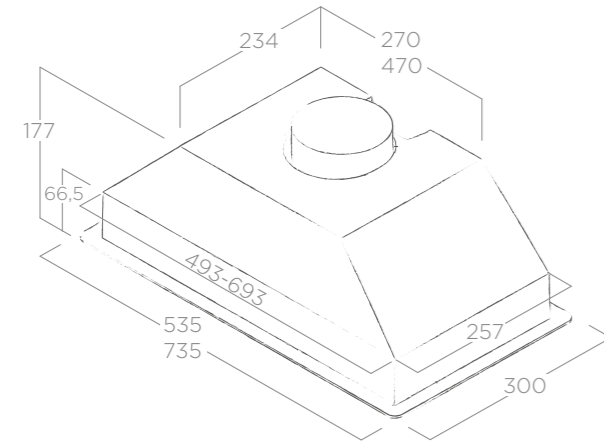

ILLUMINAZIONE LIGHTING

Tipo Type	LED 3 W
Intensità Intensity	73 LUX
Temperatura Temperature	2700 K

PERFORMANCE PERFORMANCE

Comandi Controls	Push Button 3V 3S Push Button
Portata massima Max airflow	365 m³/h
Livello sonoro Noise level	66 db(A)
Assorbimento totale Total absorption	146 W
Uscita Duct size	120 mm
Classe energetica Energy class	D (A++/E)

Filtro grassi alluminio incluso Grease aluminium filter included

ACCESSORI ACCESSORIES

Filtro carbone Charcoal Filter	CFC0141571
--------------------------------	------------

MODELLI MODELS

ERA C WH/A/60	PRF0142716
ERA C WH/A/80	PRF0142728
ERA C IX/A/60	PRF0142723
ERA C IX/A/80	PRF0142741



SCHEDA TECNICA TECHNICAL FEATURES

Misure Size	60 - 80 cm
Versione Version	Aspirante Duct-out
Finiture Finish	Silver Silver

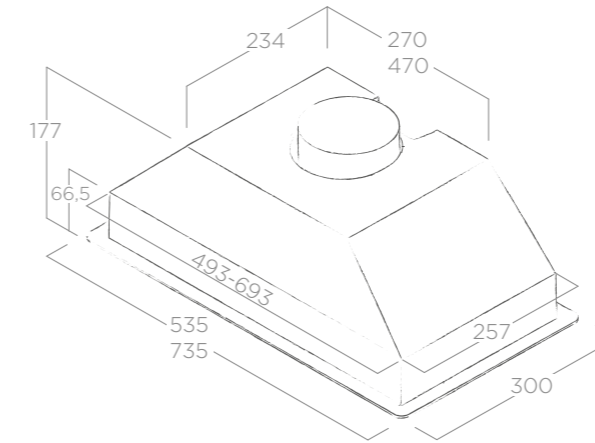

ILLUMINAZIONE LIGHTING

Tipo Type	LED 3 W
Intensità Intensity	73 LUX
Temperatura Temperature	2700 K

PERFORMANCE PERFORMANCE

Comandi Controls	Slider 3V 3S Slider
Portata massima Max airflow	220 m³/h
Livello sonoro Noise level	54 db(A)
Assorbimento totale Total absorption	90 W
Uscita Duct size	120 mm
Classe energetica Energy class	C (A++/E)

Filtro grassi alluminio incluso Grease aluminium filter included

ACCESSORI ACCESSORIES

Filtro carbone Charcoal Filter	CFC0141571
--------------------------------	------------

MODELLI MODELS

ERA GR/A/60	PRF0142633
ERA GR/A/80	PRF0142701



BOX IN

ELICA DESIGN CENTER



SCHEDA TECNICA TECHNICAL FEATURES

Misure Size	60 - 90 - 120 cm
Versione Version	Aspirante Duct-out
Finiture Finish	Acciaio inox Stainless steel

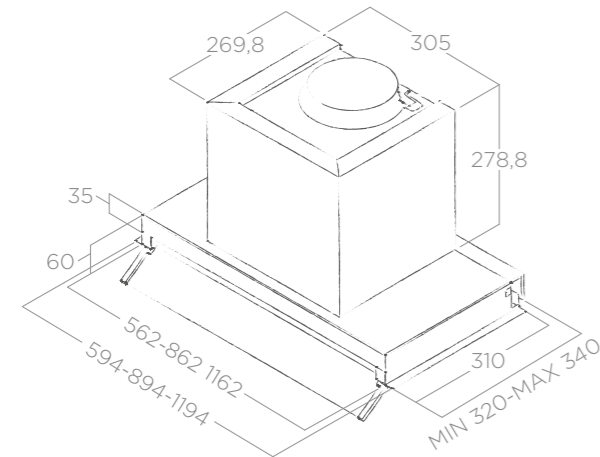

ILLUMINAZIONE LIGHTING

Tipo Type	STD	LUX
Intensità Intensity	LED 2 x 2,5 W	LED 2 x 2,5 W
Temperatura Temperature	145 LUX	145 LUX
	3500 K	4000 K

PERFORMANCE PERFORMANCE

Comandi Controls	STD	LUX
	Rotativo 3V	Rotativo 3V
	3S Rotative	3S Rotative
Portata massima Max airflow	370 m³/h	580 m³/h
Livello sonoro Noise level	67 db(A)	67 db(A)
Assorbimento totale Total absorption	95 W	180 W
Uscita Duct size	150 mm	150 mm
Classe energetica Energy class	D (A+/E)	B (A+/E)

Filtro grassi alluminio incluso Grease aluminium filter included

ACCESSORI ACCESSORIES

Filtro carbone Charcoal Filter	CFC0140343
Filtro carbone* Charcoal Filter*	CFC0141497
Kit camino H12 Chimney Kit H12	KIT0091876
Kit camino telescopico H18+H18 Telescopic Chimney Kit H18+H18	KIT0141458

MODELLI MODELS

BOXIN IX/A/60*	PRF0097835B
BOXIN IX/A/90*	PRF0097839B
BOXIN IX/A/120*	PRF0097842B
BOXIN LX/IX/A/60	PRF0114760
BOXIN LX/IX/A/90	PRF0114761
BOXIN LX/IX/A/120	PRF0114762

ELIBLOC HT

ELICA DESIGN CENTER



SCHEDA TECNICA TECHNICAL FEATURES

Misure Size	60 - 80 cm
Versione Version	Aspirante Duct-out
Finiture Finish	Silver Silver

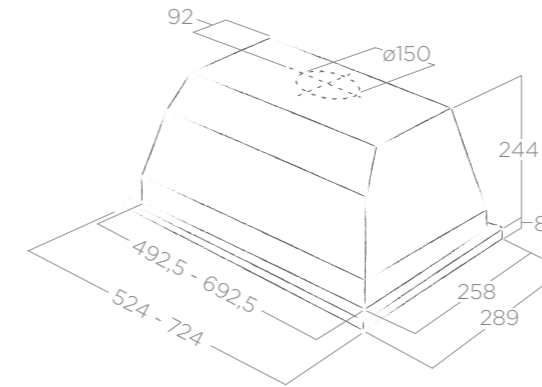

ILLUMINAZIONE LIGHTING

Tipo Type	LED 2 x 5 W
Intensità Intensity	281 LUX
Temperatura Temperature	3000 K

PERFORMANCE PERFORMANCE

Comandi Controls	Slider 4V 4s Slider
Portata massima Max airflow	645 m³/h
Livello sonoro Noise level	71 db(A)
Assorbimento totale Total absorption	210 W
Uscita Duct size	150 mm
Classe energetica Energy class	C (A+/E)

Filtro grassi alluminio incluso Grease aluminium filter included

ACCESSORI ACCESSORIES

Filtro carbone Charcoal Filter	CFC0140122
--------------------------------	------------

MODELLI MODELS

ELIBLOC HT GR A/60	1768336A
ELIBLOC HT GR/A/80	17614580A



ELITE 35

ELICA DESIGN CENTER



SCHEDA TECNICA TECHNICAL FEATURES

Misure Size	60 - 90 cm
Versione Version	Aspirante Duct-out
Finiture Finish	Silver + acciaio inox Silver + stainless steel

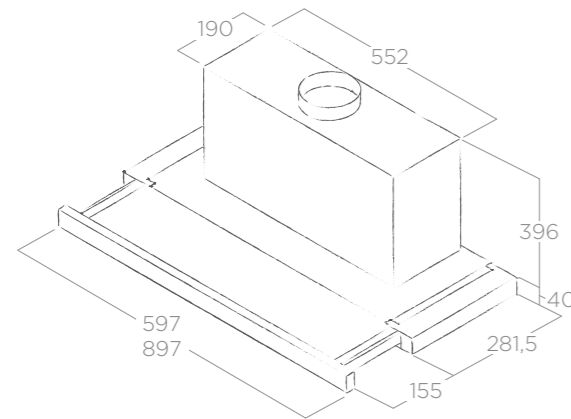

ILLUMINAZIONE LIGHTING

Tipo Type	LED 2 x 3 W
Intensità Intensity	54 LUX
Temperatura Temperature	2700 K

PERFORMANCE PERFORMANCE

Comandi Controls	Touch Control 3V+I 3S+B Touch Control
Portata intensiva Booster airflow	645 m³/h
Livello sonoro Noise level	63 db(A)
Assorbimento totale Total absorption	206 W
Uscita Duct size	150 mm
Classe energetica Energy class	A (A**/E)

Filtro grassi alluminio incluso Grease aluminium filter included

ACCESSORI ACCESSORIES

Filtro carbone Charcoal Filter	CFC0140075
--------------------------------	------------

MODELLI MODELS

ELITE 35 GRIX/A/60	PRF0139077
ELITE 35 GRIX/A/90	PRF0139069

ELITE 14

ELICA DESIGN CENTER



SCHEDA TECNICA TECHNICAL FEATURES

Misure Size	60 - 90 cm
Versione Version	Aspirante Duct-out
Finiture Finish	Silver + acciaio inox Silver + stainless steel

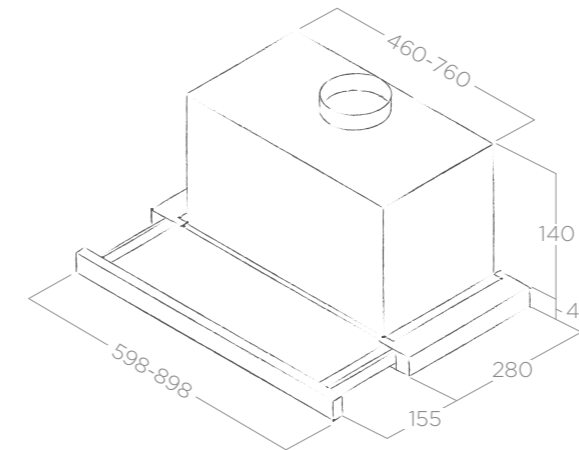

ILLUMINAZIONE LIGHTING

Tipo Type	LED 2 x 3 W
Intensità Intensity	78 LUX
Temperatura Temperature	3500 K

PERFORMANCE PERFORMANCE

Comandi Controls	Pulsantiera Meccanica 3V 3s Mechanical Push Button
Portata massima Max airflow	304 m³/h
Livello sonoro Noise level	62 db(A)
Assorbimento totale Total absorption	121 W
Uscita Duct size	120 mm
Classe energetica Energy class	D (A**/E)

Filtro grassi alluminio incluso Grease aluminium filter included

ACCESSORI ACCESSORIES

Filtro carbone Charcoal Filter	CFC0141571
--------------------------------	------------

MODELLI MODELS

ELITE 14 LUX GRIX/A/60	PRF0037989B
ELITE 14 LUX GRIX/A/90	PRF0037992B



ESTRAIBILE

ELICA DESIGN CENTER



SCHEDA TECNICA TECHNICAL FEATURES

Misure Size	60 - 90 cm
Versione Version	Filtrante Recycling
Finiture Finish	Silver, Silver + acciaio inox Silver, Silver + stainless steel

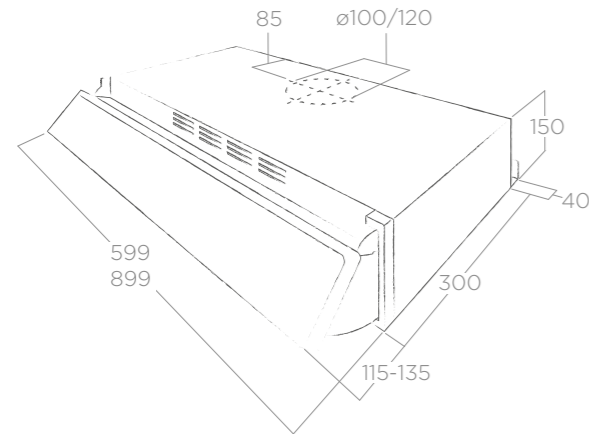

ILLUMINAZIONE LIGHTING

Tipo Type	STD	LUX
Intensità Intensity	LED 1 x 3 W	2 x 3 W
Temperatura Temperature	49 LUX	98 LUX
	2700 K	2700 K

PERFORMANCE PERFORMANCE

Comandi Controls	STD	LUX
	Slider 3V	Slider 3V
	3S Slider	3S Slider
Portata massima Max airflow	175 m³/h	280 m³/h
Livello sonoro Noise level	65 db(A)	73 db(A)
Assorbimento totale Total absorption	93 W	176 W
Uscita Duct size	120 mm	120 mm
Classe energetica Energy class	D (A++/E)	E (A++/E)

Filtro grassi alluminio incluso Grease aluminium filter included
Filtro carbone incluso Charcoal filter included

ACCESSORI ACCESSORIES

Filtro carbone Charcoal Filter	CFC0141601
--------------------------------	------------

MODELLI MODELS

ESTRAIBILE T ST GR/F/60	67014903A
ESTRAIBILE T ST GR/F/90	67014904A
ESTRAIBILE T LX GR/F/60	67014905A
ESTRAIBILE T LX GR/F/90	67014906A
ESTRAIBILE T LX GR-FR.IX/F/60	67014907A
ESTRAIBILE T LX GR-FR.IX/F/90	67014909A

KREA

ELICA DESIGN CENTER



SCHEDA TECNICA TECHNICAL FEATURES

Misure Size	60 - 90 cm
Versione Version	Filtrante Recycling
Finiture Finish	Acciaio inox, bianco, nero Stainless steel, white, black

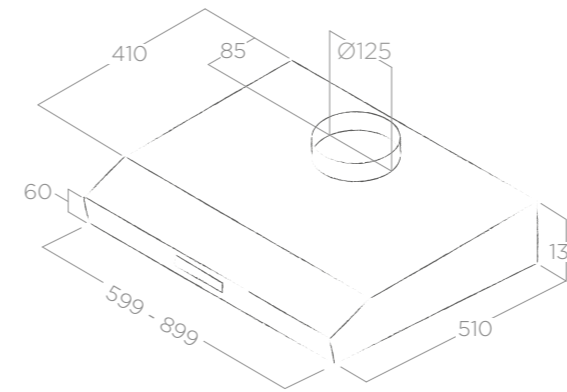

ILLUMINAZIONE LIGHTING

Tipo Type	STD	GFA	LUX
Intensità Intensity	LED 1 x 3 W	LED 2 x 3 W	LED 2 x 3 W
Temperatura Temperature	42 LUX	85 LUX	85 LUX
	2700 K	2700 K	2700 K

PERFORMANCE PERFORMANCE

Comandi Controls	ST	GFA	LX
	Slider 3V	Slider 3V	Slider 3V
	3S Slider	3S Slider	3S Slider
Portata massima Max airflow	272 m³/h	272 m³/h	335 m³/h
Livello sonoro Noise level	71 db(A)	71 db(A)	73 db(A)
Assorbimento totale Total absorption	118 W	121 W	166 W
Uscita Duct size	120 mm	120 mm	120 mm
Classe energetica Energy class	D (A++/E)	D (A++/E)	D (A++/E)

Filtro grassi alluminio incluso Grease aluminium filter included
Filtro carbone incluso Charcoal filter included

ACCESSORI ACCESSORIES

Filtro carbone Charcoal Filter	CFC0140064
--------------------------------	------------

MODELLI MODELS

KREA ST IX F/60	55311065B
KREA ST IX F/90	55311075B
KREA GFA WH/F/60	55310774B
KREA GFA WH/F/90	PRF0104636B
KREA GFA BL/F/60	PRF0104634B
KREA GFA BL/F/90	PRF0104635B
KREA LX IX F/60	55311112A
KREA LX IX F/90	55311129A





ADD OR REPLACE

Performance nel tempo e versatilità. Elica è sempre presente, grazie alla sua gamma di accessori originali e al supporto di un Servizio Clienti a completa disposizione.

Performance over time and versatility. Elica is always ready, thanks to its range of original accessories and its Customer Service team, at your complete disposal.

APPROFONDIMENTI PERFORMANCE
LEARN MORE ABOUT PERFORMANCE

	ENERGY CLASS	1 SPEED (airflow-noise)	2 SPEED (airflow-noise)	3 SPEED (airflow-noise)	4 SPEED * (airflow-noise)	5 SPEED * (airflow-noise)	NO RETURN VALVE
Acuta	A	270 m³/h - 46 db(A)	365 m³/h - 53 db(A)	515 m³/h - 60 db(A)	625 m³/h - 65 db(A)	---	√
Belt	C	280 m³/h - 50 db(A)	450 m³/h - 58 db(A)	600 m³/h - 68 db(A)	690 m³/h - 71 db(A)	---	√
Boxin Lux	B	240 m³/h - 46 db(A)	365 m³/h - 56 db(A)	580 m³/h - 67 db(A)	---	---	
Boxin Std	D	195 m³/h - 48 db(A)	215 m³/h - 54 db(A)	365 m³/h - 67 db(A)	---	---	
Circus	D	195 m³/h - 55 db(A)	220 m³/h - 56 db(A)	365 m³/h - 62 db(A)	---	---	
Circus Plus	A	220 m³/h - 45 db(A)	290 m³/h - 51 db(A)	445 m³/h - 62 db(A)	600 m³/h - 69 db(A)	---	
Circus Plus Island	A	220 m³/h - 45 db(A)	290 m³/h - 51 db(A)	445 m³/h - 62 db(A)	600 m³/h - 69 db(A)	---	
Cloud Seven (Duct-out)	A++	225 m³/h - 46 db(A)	400 m³/h - 57 db(A)	460 m³/h - 61 db(A)	700 m³/h - 71 db(A)	760 m³/h - 72 db(A)	√
Cloud Seven (Filtering)	N/A **	215 m³/h - 52 db(A)	340 m³/h - 62 db(A)	475 m³/h - 71 db(A)	550 m³/h - 74 db(A)	---	
Cruise	B	285 m³/h - 51 db(A)	410 m³/h - 60 db(A)	580 m³/h - 69 db(A)	710 m³/h - 73 db(A)	---	√
Elektra	C	255 m³/h - 45 db(A)	370 m³/h - 55 db(A)	515 m³/h - 63 db(A)	645 m³/h - 68 db(A)	---	
Elibloc HT	C	255 m³/h - 49 db(A)	365 m³/h - 58 db(A)	485 m³/h - 65 db(A)	645 m³/h - 71 db(A)	---	
Elite 14	D	125 m³/h - 46 db(A)	160 m³/h - 50 db(A)	304 m³/h - 62 db(A)	---	---	√
Elite 35	A	255 m³/h - 46 db(A)	380 m³/h - 55 db(A)	535 m³/h - 63 db(A)	645 m³/h - 67 db(A)	---	√
Era	C	125 m³/h - 45 db(A)	155 m³/h - 47 db(A)	220 m³/h - 54 db(A)	---	---	√
Era C	D	270 m³/h - 58 db(A)	325 m³/h - 63 db(A)	365 m³/h - 66 db(A)	---	---	√
Era S	B	250 m³/h - 56 db(A)	335 m³/h - 63 db(A)	420 m³/h - 68 db(A)	---	---	√
Estraibile Lux	E	115 m³/h - 53 db(A)	205 m³/h - 69 db(A)	280 m³/h - 73 db(A)	---	---	
Estraibile Std	D	75 m³/h - 45 db(A)	95 m³/h - 75 db(A)	175 m³/h - 65 db(A)	---	---	
Flat Glass	D	195 m³/h - 55 db(A)	220 m³/h - 56 db(A)	365 m³/h - 62 db(A)	---	---	√
Flat Glass Plus	A	220 m³/h - 45 db(A)	290 m³/h - 51 db(A)	445 m³/h - 62 db(A)	600 m³/h - 69 db(A)	---	
Flat Glass Plus Island	A	220 m³/h - 45 db(A)	290 m³/h - 51 db(A)	445 m³/h - 62 db(A)	600 m³/h - 69 db(A)	---	
Hydra	C	195 m³/h - 46 db(A)	350 m³/h - 49 db(A)	495 m³/h - 68 db(A)	---	---	
Joy	B	285 m³/h - 51 db(A)	420 m³/h - 61 db(A)	580 m³/h - 69 db(A)	710 m³/h - 73 db(A)	---	
Joy Island	B	285 m³/h - 51 db(A)	420 m³/h - 61 db(A)	580 m³/h - 69 db(A)	710 m³/h - 73 db(A)	---	√
Juno	A	240 m³/h - 47 db(A)	320 m³/h - 54 db(A)	600 m³/h - 67 db(A)	---	---	
Juno Urban	A	240 m³/h - 47 db(A)	320 m³/h - 54 db(A)	600 m³/h - 67 db(A)	---	---	
Krea ST	D	115 m³/h - 52 db(A)	208 m³/h - 62 db(A)	272 m³/h - 71 db(A)	---	---	

* Velocità intensive temporizzate *Booster time speeds

** Modello non soggetto a certificazione energetica obbligatoria *Model not subject to compulsory energy certification.

APPROFONDIMENTI PERFORMANCE
LEARN MORE ABOUT PERFORMANCE

	ENERGY CLASS	1 SPEED (airflow-noise)	2 SPEED (airflow-noise)	3 SPEED (airflow-noise)	4 SPEED * (airflow-noise)	5 SPEED * (airflow-noise)	NO RETURN VALVE
Krea LX	D	135 m³/h - 52 db(A)	185 m³/h - 59 db(A)	335 m³/h - 73 db(A)	---	---	
Krea GFA	D	115 m³/h - 52 db(A)	208 m³/h - 62 db(A)	272 m³/h - 71 db(A)	---	---	
Kuadra	D	220 m³/h - 48 db(A)	320 m³/h - 55 db(A)	415 m³/h - 62 db(A)	495 m³/h - 66 db(A)	---	√
Kuadra Island	D	220 m³/h - 48 db(A)	320 m³/h - 55 db(A)	415 m³/h - 62 db(A)	495 m³/h - 66 db(A)	---	√
L'Essenza	B	280 m³/h - 49 db(A)	430 m³/h - 57 db(A)	600 m³/h - 65 db(A)	690 m³/h - 68 db(A)	---	√
Lol	B	270 m³/h - 49 db(A)	380 m³/h - 56 db(A)	515 m³/h - 65 db(A)	665 m³/h - 70 db(A)	---	√
Missy	D	165 m³/h - 49 db(A)	245 m³/h - 51 db(A)	392 m³/h - 68 db(A)	---	---	√
Naked	B	205 m³/h - 51 db(A)	275 m³/h - 59 db(A)	380 m³/h - 66 db(A)	515 m³/h - 72 db(A)	---	
Naked Urban	B	205 m³/h - 51 db(A)	275 m³/h - 59 db(A)	380 m³/h - 66 db(A)	515 m³/h - 72 db(A)	---	
Personal	C	225 m³/h - 48 db(A)	350 m³/h - 57 db(A)	545 m³/h - 67 db(A)	---	---	
Reef	B	285 m³/h - 50 db(A)	410 m³/h - 60 db(A)	580 m³/h - 68 db(A)	710 m³/h - 73 db(A)	---	√
Reef Island	B	285 m³/h - 50 db(A)	410 m³/h - 59 db(A)	580 m³/h - 68 db(A)	710 m³/h - 73 db(A)	---	√
Rubino Corner	C	220 m³/h - 42 db(A)	330 m³/h - 51 db(A)	600 m³/h - 64 db(A)	---	---	
Shire	B	460 m³/h - 60 db(A)	625 m³/h - 60 db(A)	N/A m³/h - N/A db(A)	710 m³/h - 66 db(A)	---	√
Spot Ng	D	195 m³/h - 55 db(A)	220 m³/h - 56 db(A)	365 m³/h - 62 db(A)	---	---	√
Spot Plus	A	220 m³/h - 44 db(A)	295 m³/h - 50 db(A)	445 m³/h - 62 db(A)	625 m³/h - 69 db(A)	---	
Spot Plus Island	A	220 m³/h - 44 db(A)	295 m³/h - 50 db(A)	535 m³/h - 64 db(A)	600 m³/h - 70 db(A)	---	
Spot Urban	B	240 m³/h - 46 db(A)	335 m³/h - 55 db(A)	600 m³/h - 69 db(A)	---	---	√
Stone	C	255 m³/h - 49 db(A)	360 m³/h - 57 db(A)	625 m³/h - 70 db(A)	---	---	
Stripe	B	280 m³/h - 50 db(A)	430 m³/h - 58 db(A)	600 m³/h - 65 db(A)	755 m³/h - 69 db(A)	---	√
Stripe Urban	B	280 m³/h - 50 db(A)	430 m³/h - 58 db(A)	600 m³/h - 65 db(A)	755 m³/h - 69 db(A)	---	√
Synthesis	C	240 m³/h - 44 db(A)	370 m³/h - 55 db(A)	495 m³/h - 63 db(A)	555 m³/h - 67 db(A)	---	
Tamaya	D	266 m³/h - 60 db(A)	320 m³/h - 65 db(A)	350 m³/h - 67 db(A)	---	---	
Tonda	D	266 m³/h - 60 db(A)	320 m³/h - 65 db(A)	350 m³/h - 67 db(A)	---	---	
Tribe	B	285 m³/h - 50 db(A)	410 m³/h - 60 db(A)	580 m³/h - 68 db(A)	710 m³/h - 73 db(A)	---	√
Tribe Island	B	285 m³/h - 50 db(A)	410 m³/h - 59 db(A)	580 m³/h - 68 db(A)	710 m³/h - 73 db(A)	---	√
Tube Pro	C	240 m³/h - 47 db(A)	365 m³/h - 56 db(A)	600 m³/h - 68 db(A)	---	---	√
Tube Pro Island	C	240 m³/h - 47 db(A)	365 m³/h - 56 db(A)	600 m³/h - 68 db(A)	---	---	√
Vega	D	115 m³/h - 52 db(A)	208 m³/h - 62 db(A)	272 m³/h - 71 db(A)	---	---	

FILTRO LUNGA DURATA LONG LIFE FILTER



Il long life filter ha le stesse caratteristiche del revolution filter ma con un'efficienza di filtraggio che si aggira tra il 40-60%.

The Long Life Filter has the same characteristics of the revolution filter, but with a filtering efficiency that ranges from 40-60%.

FILTRO CARBONE CHARCOAL FILTER



Il filtro odori tradizionale, composto da una miscela di carboni attivi, perde la sua efficacia attraverso il suo utilizzo ed ha una vita media di 3-6 mesi.

The traditional odour filter, made up of a mix of activated carbons, loses its efficiency through use and has an average life of 3-6 months.

	CODICE FILTRO FILTER CODE	TIPO FILTRO FILTER TYPE
ACUTA	CFC0140343	Carbone/Charcoal
BELT	CFC0140343	Carbone/Charcoal
BOXIN LUX	CFC0140343	Carbone/Charcoal
BOXIN STD	CFC0141497	Carbone/Charcoal
CIRCUS	CFC0141529	Carbone/Charcoal
	CFC0141725	Long Life
CIRCUS PLUS	CFC0141529	Carbone/Charcoal
	CFC0141725	Long Life
CIRCUS PLUS ISLAND	CFC0141529	Carbone/Charcoal
	CFC0141725	Long Life
CLOUD SEVEN	CFC0140426	Long Life
CRUISE	CFC0141529	Carbone/Charcoal
	CFC0141725	Long Life
ELEKTRA	CFC0140088	Long Life
ELIBLOC HT	CFC0140122	Carbone/Charcoal
ELITE 14	CFC0141571	Carbone/Charcoal
ELITE 35	CFC0140075	Carbone/Charcoal
ERA	CFC0141571	Carbone/Charcoal
ERA C	CFC0141571	Carbone/Charcoal
ERA S	CFC0141571	Carbone/Charcoal
ESTRAIBILE	CFC0141601	Carbone/Charcoal
FLAT GLASS	CFC0141529	Carbone/Charcoal
	CFC0141725	Long Life
FLAT GLASS PLUS	CFC0141529	Carbone/Charcoal
	CFC0141725	Long Life
FLAT GLASS PLUS ISLAND	CFC0141529	Carbone/Charcoal
	CFC0141725	Long Life
HYDRA	CFC0140122	Carbone/Charcoal
JOY	CFC0141529	Carbone/Charcoal
	CFC0141725	Long Life
JOY ISLAND	CFC0141529	Carbone/Charcoal
	CFC0141725	Long Life
JUNO	CFC0140088	Long Life
JUNO URBAN	CFC0140088	Long Life
KREA	CFC0140064	Carbone/Charcoal
KUADRA	CFC0140423	Long Life
KUADRA ISLAND	CFC0140423	Long Life

	CODICE FILTRO FILTER CODE	TIPO FILTRO FILTER TYPE
L'ESSENZA	CFC0140343	Carbone/Charcoal
LOL	CFC0141529	Carbone/Charcoal
	CFC0141725	Long Life
MISSY	CFC0141497	Carbone/Charcoal
NAKED	CFC0140384	Long Life
NAKED URBAN	CFC0140384	Long Life
PERSONAL	CFC0141529	Carbone/Charcoal
	CFC0141725	Long Life
REEF	CFC0141529	Carbone/Charcoal
	CFC0141725	Long Life
REEF ISLAND	CFC0141529	Carbone/Charcoal
	CFC0141725	Long Life
RUBINO CORNER	CFC0140124	Carbone/Charcoal
SHIRE	CFC0140343	Carbone/Charcoal
SPOT NG	CFC0141529	Carbone/Charcoal
	CFC0141725	Long Life
SPOT PLUS	CFC0141529	Carbone/Charcoal
	CFC0141725	Long Life
SPOT PLUS ISLAND	CFC0141529	Carbone/Charcoal
	CFC0141725	Long Life
SPOT URBAN	CFC0141529	Carbone/Charcoal
	CFC0141725	Long Life
STONE	CFC0141529	Carbone/Charcoal
	CFC0141725	Long Life
STRIPE	CFC0140343	Carbone/Charcoal
STRIPE URBAN	CFC0140343	Carbone/Charcoal
SYNTHESIS	CFC0141529	Carbone/Charcoal
	CFC0141725	Long Life
TAMAYA	CFC0140124	Carbone/Charcoal
TONDA	CFC0140124	Carbone/Charcoal
TRIBE	CFC0141529	Carbone/Charcoal
	CFC0141725	Long Life
TRIBE ISLAND	CFC0141529	Carbone/Charcoal
	CFC0141725	Long Life
TUBE PRO	CFC0140423	Long Life
TUBE PRO ISLAND	CFC0140423	Long Life
VEGA	CFC0140064	Carbone/Charcoal

FILTRI GRASSI GREASE FILTERS

FILTRO GRASSI ALLUMINIO GREASE FILTER ALUMINIUM



Filtro grassi a strati in alluminio (GFA). Questo filtro è il più diffuso sul mercato anche perché grazie alla sua dimensione può essere facilmente lavato a mano e in lavastoviglie.

Layered aluminum grease filter (GFA). This filter is the most common on the market, also because, thanks to its size it can be easily washed by hand, or in the dishwasher.

KIT GREASE FILTER ALUMINIUM

KIT0010805

DISPONIBILE PER Available for
ACUTA / CRUISE / HYDRA / JOY / JOY ISLAND / JUNO / JUNO URBAN /
L'ESSENZA / MISSY / RUBINO CORNER / SPOT PLUS / SPOT PLUS ISLAND /
SPOT URBAN / STRIPE / STRIPE URBAN / TAMAYA

FILTRO PROFESSIONAL BUFFLE PROFESSIONAL FILTER BUFFLE



Filtro grassi completamente in acciaio che dà al prodotto un aspetto tipico delle cappe industriali. Grazie al labirinto degli strati in acciaio, questo filtro ha un'elevata captazione dei grassi.

All steel grease filter that gives the product a typical industrial hood look. Thanks to the labyrinth of steel layers, this filter has a high grease capturing capacity.

KIT PROFESSIONAL BUFFLE

KIT0010804

DISPONIBILE PER Available for
ACUTA / CRUISE / HYDRA / JOY / JOY ISLAND / JUNO / JUNO URBAN /
L'ESSENZA / MISSY / RUBINO CORNER / SPOT PLUS / SPOT PLUS ISLAND /
SPOT URBAN / STRIPE / STRIPE URBAN / TAMAYA

FILTRO PROFESSIONAL INOX PROFESSIONAL STAINLESS STEEL FILTER



Filtro grassi con primo strato in acciaio e lamiera microforata posteriore, facilmente lavabile e con un'elevata captazione dei grassi.

Grease filter with the first layer in steel and a microperforated back metal sheet, easily washable and with high grease capturing capacity.

KIT PROFESSIONAL INOX ALEPH

KIT0010806

DISPONIBILE PER Available for
ACUTA / CRUISE / HYDRA / JOY / JOY ISLAND / JUNO / JUNO URBAN /
L'ESSENZA / MISSY / RUBINO CORNER / SPOT PLUS / SPOT PLUS ISLAND /
SPOT URBAN / STRIPE / STRIPE URBAN / TAMAYA

RADIOCOMANDI REMOTE CONTROLS

Il nuovo radiocomando Elica, disegnato da Fabrizio Crisà, è ultrasottile, resistente e pratico grazie ai magneti che ne consentono il posizionamento su oggetti metallici. In vetro e alluminio. Disponibile nella versione bianca o nera.

The new Elica radio control, designed by Fabrizio Crisà, is super thin, resistant and practical, thanks to the magnets that allow it to be placed on metal object. It comes in glass and aluminum, in black or white.

KIT0121468 BIANCO WHITE

KIT0121469 NERO BLACK



CONSENTE DI ACCENDERE LA LUCE AMBIENTE.
CON UNA PRESSIONE PROLUNGATA SI HA LA POSSIBILITÀ DI REGOLARE L'INTENSITÀ DELLA LUCE.

Allows you to turn on the AMBIENT LIGHT. Hold down for a longer time to adjust the brightness of the light.

BATTERIA RICARICABILE CON PRESA MICRO USB (CAVO IN DOTAZIONE).

Rechargeable battery with micro USB plug. (cord included).



IL TASTO + AUMENTA LA POTENZA DI ASPIRAZIONE MENTRE IL - LA RIDUCE.
TENENDO PREMUTO QUEST'ULTIMO LA CAPPA, A PRESCINDERE DALLA VELOCITÀ IN CUI SI TROVA, SI SPENGE.

The + key increases the aspiration power, while the - key decreases it. By holding down the latter, the hood switches off regardless of its current speed.

LA LUCE SUL PIANO COTTURA SI ACCENDE CON UNA LEGGERA PRESSIONE DEL TASTO.
CON UNA PRESSIONE PROLUNGATA SI ATTIVANO, A SECONDA DEI MODELLI, LE FUNZIONALITÀ AVANZATE: LA DIM-LIGHT (CHE REGOLA L'INTENSITÀ DELLA LUCE) O LA TUNE-WHITE (CHE PERMETTE LA VARIAZIONE DELLA TEMPERATURA DEI LED).

The LIGHT above the HOB is switched on by lightly pressing the key. By holding it down for a longer period, you can activate the advanced features, according to your model: the DIM-LIGHT (that adjusts brightness) or the TUNE-WHITE (that allows for the variation of the led light temperature)

SERIE 150X70 Ø 125

1052A



150x70x1000mm

1052B



150x70x1500mm

1052C



150x70x1000mm

1052F



90° 150x70mm

1052G



150x70 - Ø125mm

1052L



Ø125-100mm

1052N



Ø125x1000mm

1052W



Ø125x3000mm

1052O



Ø125x1000mm

1052P



Ø125

1052Q



150x70 - Ø125mm

1052R



90° Ø125mm

1052D



150x70mm

1052E



90° 150x70mm

KIT0094727



Ø125x750mm + fascette

SERIE 220X90 Ø 150

1053M



220x90x1000mm

1052AD



Ø150x3000mm

1053R



90° 220x90mm

1053S



90° 220x90mm

1053W



Ø150x1000mm

1053Y



90° Ø150mm

1053Q



220x90 - Ø150mm

1053Z



Ø150

1053N



220x90mm

1052M



Ø150-125mm

1053P



220x90 - Ø150mm

KIT0094725



Ø150x750mm + fascette

TU E LA CAPP THE HOOD AND YOU

PERCHÉ LA CAPP

LA CAPP È FONDAMENTALE PER RESPIRARE ARIA PULITA IN CUCINA.

La sua funzione principale consiste nel migliorare la qualità dell'aria, eliminando i fumi della combustione, i cattivi odori e i vapori della cottura, dannosi sia per le persone che per mobili e pareti.

La cappa è un prezioso alleato del tuo benessere. Per questo, scegliendo una cappa ci si deve assicurare che garantisca:

- Una performance di aspirazione adeguata alle tue necessità e al tuo ambiente, così da ottenere il giusto ricambio dell'aria e un minore consumo di energia elettrica
- Una fonte di luce efficace per rendere più confortevole la preparazione dei cibi
- Un design in linea con i tuoi gusti e le tue esigenze
- Una buona usabilità e silenziosità

COME SCEGLIERLA

SCEGLI UNA CAPP CHE FACILITI IL TUO LAVORO IN CUCINA, CHE TI DIA LIBERTÀ DI MOVIMENTO E SEMPLIFICHI LA PREPARAZIONE DEI CIBI.

La cappa deve avere anche la giusta potenza di aspirazione. Valuta le dimensioni della tua cucina e le tue abitudini culinarie: solo così otterrai il giusto ricambio dell'aria e un minor consumo di energia elettrica.

Con un semplice calcolo è possibile definire quale sia la portata più adatta a ogni cucina. Basta moltiplicare per 10 il volume della stanza per ottenere la portata ideale.

Scegli con cura la tua cappa e porta aria nuova nella tua cucina.

MOLTEPLICI SONO LE POSSIBILITÀ DI INSTALLAZIONE. TROVA IL MODELLO CHE PIÙ SI ADATTA AL TUO AMBIENTE, AL TUO STILE DI VITA, AL TUO MODO DI ESSERE

- 1 A parete**
La cucina è posizionata contro la parete con il piano cottura in adiacenza al muro. Cappa da installare a parete.
- 2 A isola**
La cucina è posizionata al centro della stanza con il piano cottura distante dal muro. Cappa da installare a soffitto.
- 3 Ad angolo**
La cucina è sviluppata tra due pareti della stanza e il piano cottura è posizionato a ridosso dell'angolo. Cappa da installare tra le pareti adiacenti.
- 4 A incasso**
Il piano cottura è posizionato sotto un pensile. Cappa da installare all'interno del pensile.

WHY THE HOOD

THE HOOD IS ESSENTIAL TO BREATHE CLEAN AIR IN THE KITCHEN.

Its main function is to improve the quality of air, by eliminating burning fumes, bad cooking odours and vapours that are harmful to both people, furniture and walls.

The hood is a valuable ally for your wellbeing. This is why, when choosing one, you need to make sure that it provides:

- Suction performance suitable for your needs and environment, in order to obtain proper air flow and lower electricity consumption
- Effective light source to facilitate food preparation
- Design that suits your taste and needs
- Good usability and low noise level

HOW TO CHOOSE IT

CHOOSE A HOOD THAT FACILITATES YOUR WORK IN THE KITCHEN, AFFORDS FREEDOM OF MOVEMENT AND SIMPLIFIES FOOD PREPARATION.

The hood should also have the right suction power. Consider the size of your kitchen and your cooking habits: this is the only way to obtain the right air flow and lower electricity consumption.

A simple calculation allows understanding the most suitable capacity for every kitchen. Just multiply the volume of the room by 10 to obtain the ideal capacity.

Choose your hood carefully and bring new air into your kitchen.

THERE IS A WIDE RANGE OF INSTALLATION OPTIONS. FIND THE MODEL THAT BEST SUITS YOUR ROOM, LIFESTYLE AND WAY OF BEING

- 1 Wall-mounted**
The kitchen unit is located against the wall with the cooktop adjacent to the wall. Hood to be mounted on the wall.
- 2 Island**
The kitchen unit is located at the center of the room with the cooktop away from the wall. Hood to be mounted on the ceiling.
- 3 Corner**
The kitchen unit extends along two walls of the room and the cooktop is located in the corner. Hood to be installed between the adjacent walls.
- 4 Built-in**
The cooktop is located under a wall unit. Hood to be installed inside the wall unit.

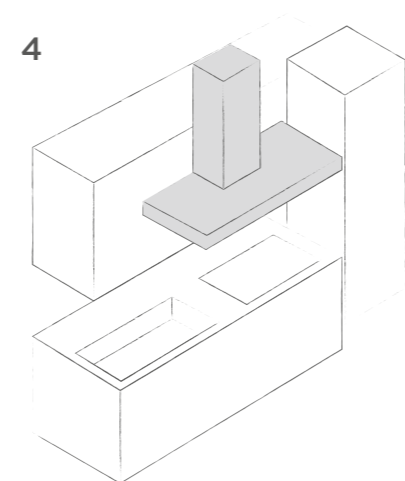
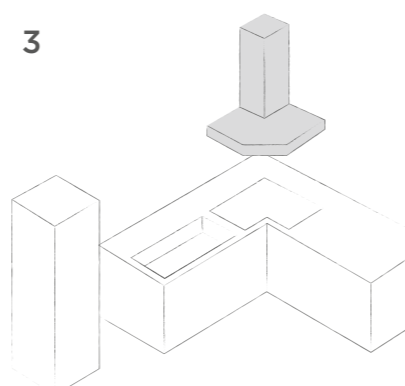
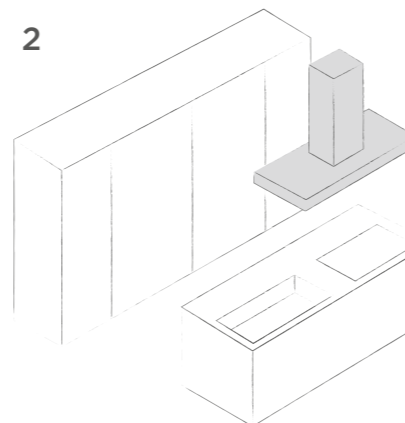
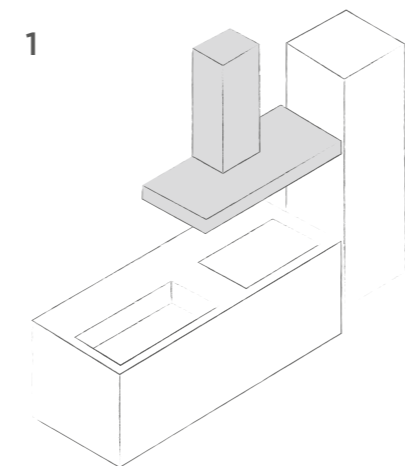

TU E LA CAPP THE HOOD AND YOU

COME INSTALLARLA

IL PERFETTO FUNZIONAMENTO DELLA CAPP È ASSICURATO DA UNA CORRETTA INSTALLAZIONE, GARANTITA DA PERSONALE SPECIALIZZATO. IL MONTAGGIO E LA MANUTENZIONE VARIANO IN BASE ALLE DUE TIPOLOGIE DI CAPP: ASPIRANTE E FILTRANTE.

Molti i modelli elica sono predisposti per lavorare in entrambe le versioni. Prima di procedere all'installazione della tua cappa, tieni a mente queste semplici regole di base:

- Segui tutte le fasi indicate nel libretto di istruzioni del prodotto;
- Collega la cappa aspirante all'esterno con una tubazione dedicata dal diametro 120-150 millimetri: una lunghezza ridotta e l'assenza di curvature garantiscono prestazioni ottimali.
- Rispetta la distanza minima dal piano cottura indicata nel libretto, al fine di evitare danni alle parti funzionali e salvaguardare la sicurezza delle persone;
- Controlla che la posizione della presa elettrica sia in prossimità del prodotto per il collegamento.
- In caso di difficoltà richiedi l'intervento di un tecnico specializzato di tua fiducia;

Il montaggio e la manutenzione variano in base alla tipologia di cappa, aspirante o filtrante

5 Cappa aspirante

La cappa aspirante espelle l'aria all'esterno dell'abitazione. È la tipologia più diffusa in quanto garantisce elevate prestazioni, alta portata e bassa rumorosità.

6 Cappa filtrante

La cappa filtrante sottrae i cattivi odori con il filtro dedicato e reimmette l'aria nell'ambiente cucina. Questa tipologia è adatta in situazioni prive del foro di evacuazione, evitando dispersioni di calore verso l'esterno.

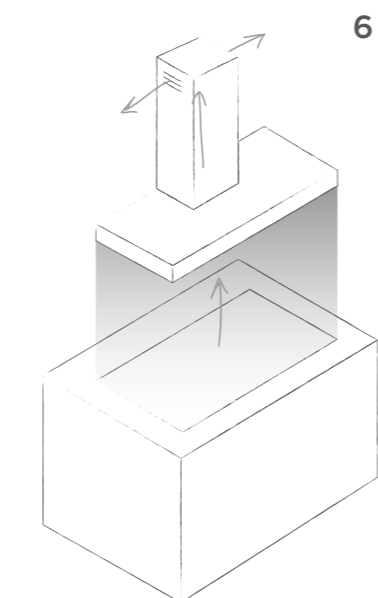
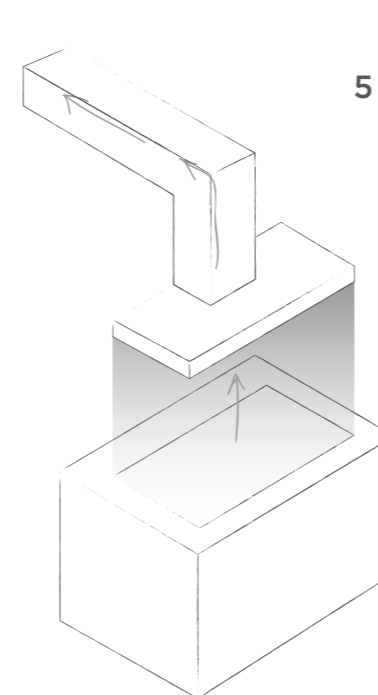

COME AVERNE CURA

PER ASSICURARE UNA LUNGA DURATA E UN CORRETTO FUNZIONAMENTO DELLA TUA CAPP, IL PRIMO PASSO È MANTENERE IN OTTIMO STATO IL SISTEMA DI FILTRAGGIO.

Due sono le tipologie di filtro:

- Il filtro grassi protegge la tua cappa trattenendo le particelle di grasso. Il filtro grassi in alluminio o inox richiede una pulizia periodica a mano con detergente neutro o in lavastoviglie a basse temperature(*). Mentre il filtro grassi carta va sostituito ogni mese in base all'utilizzo.
- Il filtro odori, a carboni attivi, installato sulle cappe filtranti, cattura e trattiene le particelle odorose dell'aria. Ricorda di sostituirlo ogni 3-4 mesi. I filtri odori long life hanno invece una durata maggiore: vanno sostituiti ogni due anni.

Semplici e piccole accortezze ti aiuteranno a mantenere sana ed efficiente la tua cappa.

(*). Verificare sempre come lavare il filtro sul libretto d'istruzione del prodotto

HOW TO INSTALL IT

THE CORRECT OPERATION OF YOUR HOOD IS ONLY ENSURED IF IT IS INSTALLED BY SPECIALIZED TECHNICIANS. ASSEMBLY AND MAINTENANCE VARY ACCORDING TO THE TWO TYPES OF HOOD: DUCT-OUT AND RECIRCULATING.

Many elica models can operate in both versions. When installing your hood, bear in mind these simple basic rules:

- Follow all the steps shown in the instruction manual of the product;
- Connect the duct-out hood to the outside with a dedicated pipe: minimized length and absence of bends ensure better performance.
- Comply with the minimum distance from the cooktop specified in the manual, in order to avoid damaging working parts and ensuring people's safety;
- Make sure that the outlet che is close to the product for connection.
- In the event of difficulties, seek assistance from a reliable specialized technician;

Assembly varies according to the type of hood, duct-out or recirculating

5 Duct-out hood

The duct-out hood exhausts air to the outside. This is the most used type, because it ensures high performance, high capacity and low noise level.

6 Recirculating hood

The recirculating hood removes bad odours by means of a dedicated charcoal filter and reintroduces air into the kitchen. This type is suitable for rooms with no extractor duct, affords air saving and avoids thermal losses to the outside.

TAKING CARE OF IT

TO ENSURE THE LONG LIFE AND CORRECT OPERATION OF YOUR HOOD IN BOTH DUCT-OUT AND RECIRCULATING VERSIONS, THE FIRST STEP IS TO KEEP THE FILTERING SYSTEM IN GOOD CONDITION.

There are two types of filters:

- The grease filter protects your hood by trapping particles of grease. The aluminum or stainless steel grease filter requires periodic cleaning by hand with neutral detergent or in the dishwasher at low temperature (*). The paper grease filter must be replaced every month depending on use.
- The active charcoal filter installed on recirculating hoods, traps odour particles of air. Remember to replace it every 3-4 months. Long life filters have a longer life: they must be replaced every two years.

Simple precautions will help you keep your hood in perfect condition.

(*). Always follow the instructions for washing the filter on the manual of the product

ETICHETTA ENERGETICA ENERGY LABEL

L'Etichetta Energetica, introdotta dalla Commissione Europea con il regolamento EU N°65/2014 ed il regolamento di Ecodesign EU N°66/2014 che fissa vari requisiti minimi di efficienza, è uno strumento fondamentale per scegliere la cappa aspirante più idonea alle proprie esigenze.

Dalla sua lettura, infatti, è possibile ottenere immediatamente informazioni non solo in merito ai suoi consumi di energia, ma anche un quadro semplice e chiaro dell'efficienza con cui essa espleta le sue funzioni. L'immagine sotto presenta un esempio di etichetta energetica e la spiegazione di ciascun suo campo. In ciascuna pagina del nostro catalogo trovate un simbolo che indica la Classe Energetica del prodotto presentato. Per ottenere informazioni dettagliate di ciascuna versione del modello di interesse, tra cui tutti i parametri riportati nell'etichetta energetica, visitate il nostro sito web www.elica.com

The Energy Label, introduced by the European Commission through Regulation (EU) No. 65/2014 and Ecodesign Regulation (EU) No. 66/2014 which defines the minimum efficiency requirements, constitutes a fundamental tool for choosing the most suitable extractor hood for the user's needs.

Indeed, the label provides instant information on energy consumption and the level of efficiency of the product's performances. The image below shows an example of an energy label with the explanation of its various sections. Each page of our catalogue contains a symbol indicating the energy class of the product presented. For obtaining detailed information on each version of the desired model, including all the parameters appearing on the energy label, visit our website at www.elica.com

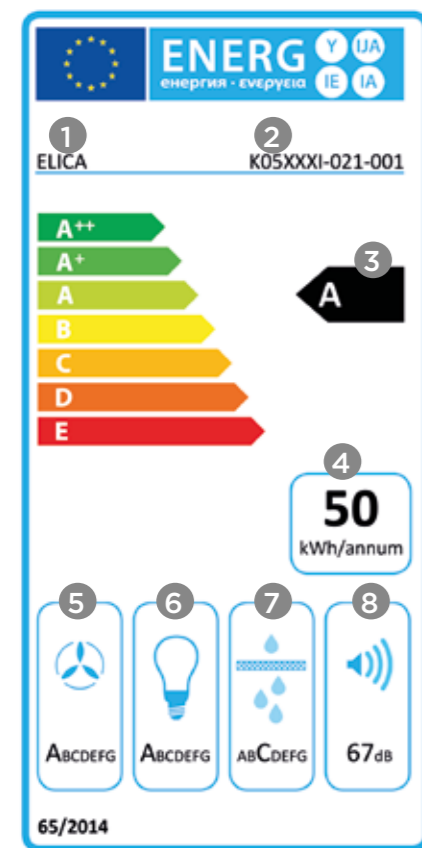

- NOME O MARCHIO DEL FORNITORE.**
SUPPLIER NAME OR BRAND.
- IDENTIFICATIVO DEL MODELLO.**
MODEL IDENTIFICATION CODE.
- CLASSE DI EFFICIENZA ENERGETICA: A++ INDICANO I LIVELLI DI MASSIMA EFFICIENZA, E QUELLO DI MINIMA.**
ENERGY EFFICIENCY CLASS: A++ DENOTE THE MAXIMUM EFFICIENCY LEVELS, E THE MINIMUM LEVEL.
- CONSUMO ANNUO DI ENERGIA STIMATO PER UTILIZZO STANDARD.**
ESTIMATED ANNUAL ENERGY CONSUMPTION FOR STANDARD USE.
- CLASSE DI EFFICIENZA FLUIDODINAMICA: INDICA L'EFFICIENZA CON CUI LA CAPP A È IN GRADO DI ASPIRARE I VAPORI GENERATI DALLA COTTURA (A MASSIMA - G MINIMA EFF.).**
FLUID DYNAMIC EFFICIENCY CLASS: INDICATES THE EFFICIENCY WITH WHICH THE HOOD IS ABLE TO EXTRACT VAPOURS GENERATED THROUGH COOKING (A MAXIMUM - G MINIMUM EFFICIENCY).
- CLASSE DI EFFICIENZA LUMINOSA: INDICA L'EFFICIENZA CON CUI LA CAPP A ILLUMINA IL PIANO COTTURA (A MASSIMA - G MINIMA EFF.).**
LIGHTING EFFICIENCY CLASS: INDICATES THE EFFICIENCY WITH WHICH THE HOOD IS ABLE TO ILLUMINATE THE COOKER HOB (A MAXIMUM - G MINIMUM EFFICIENCY).
- CLASSE DI EFFICIENZA DEL FILTRAGGIO DEI GRASSI: INDICA L'EFFICIENZA CON CUI LA CAPP A FILTRA I GRASSI GENERATI DALLA COTTURA (A MASSIMA - G MINIMA EFF.).**
GREASE FILTERING EFFICIENCY CLASS: INDICATES THE EFFICIENCY WITH WHICH THE HOOD FILTERS GREASE GENERATED THROUGH COOKING (A MAXIMUM - G MINIMUM EFFICIENCY).
- LIVELLO DI RUMOROSITÀ: INDICA IL MASSIMO LIVELLO DI RUMORE GENERATO DAL PRODOTTO NELL'UTILIZZO NORMALE.**
NOISE LEVEL: INDICATES THE MAXIMUM NOISE LEVEL GENERATED BY THE PRODUCT DURING NORMAL USE.

GARANZIA E SERVIZI WARRANTY AND SERVICES

BENVENUTO NEL SERVICE DI ELICA

NUMERO VERDE 800 888 444

Un centro informativo specializzato a disposizione di clienti finali e operatori dal lunedì al venerdì dalle 08:00 alle 20:00 e il sabato dalle 08:00 alle 14:00.

CENTRI ASSISTENZA

Il Servizio Clienti Elica ti garantisce una copertura capillare del territorio nazionale con oltre 200 centri assistenza autorizzati.

SUPPORTO DEDICATO SU elica.com

È possibile eseguire il download dei libretti di istruzioni direttamente su elica.com. Inoltre, per ulteriori approfondimenti, è disponibile il servizio assistenza da contattare tramite e-mail.

ACCESSORI E RICAMBI ORIGINALI

Una corretta manutenzione e la regolare sostituzione dei filtri carbone sono fondamentali per garantire il perfetto funzionamento dei nostri prodotti.

GARANZIA 24 MESI

Tutti i prodotti Elica godono della garanzia legale di 2 anni a partire dalla data di acquisto del prodotto.

Ma perché accontentarsi
quando puoi avere di più?

ACQUISTA DEEP BREATHE ASSISTANCE PER AVERE FINO A 5 ANNI DI GARANZIA

- Estensione dell'assistenza a cinque anni
- Nessun costo aggiuntivo per intervento
- Ricambi originali Elica
- Centri assistenza selezionati

Chiama il numero verde o collegati al sito shop.elica.com

WELCOME TO ELICA SERVICE

TOLL FREE NUMBER 800 888 444

A specialist information centre is available to customers and operators from Monday to Friday, from 8.00am to 8.00pm and Saturdays from 8.00am to 2.00pm.

SERVICE CENTRES

Elica Customer Service guarantees capillary coverage throughout the national territory with more than 200 authorised service centres.

DEDICATED SUPPORT ON elica.com

Instruction handbooks can be downloaded directly on elica.com. Moreover, for more information, the help service can be contacted via email.

ACCESSORIES AND ORIGINAL SPARE PARTS

Proper maintenance and the regular replacement of carbon filters is essential in guaranteeing the perfect operation of our products.

24-MONTH WARRANTY

All Elica products enjoy a 2-year manufacturer's warranty, effective from the date of purchase.

Why settle
when you can have more?

PURCHASE DEEP BREATHE ASSISTANCE FOR AN EXTENDED WARRANTY UP TO 5 YEARS

- Extension of service up to five years
- No additional labour costs
- Elica original spare parts
- Selected service centres

Call the toll free number or visit the website shop.elica.com



shop.elica.com

REALIZED BY ELICA TEAM
BARBARA PERSIGILLI
LUCIO BUSELLI
Graphic Design
and Coordination

IN COLLABORATION WITH

YOUNG & RUBICAM - MILANO
Project Art Direction

ARCHÈ AGENCY - PESARO
Scenic Art Direction
Photorealistic 3D

SELECOLOR - FIRENZE
Post Production
Color Separation

GRAFICHE ANTIGA - TREVISO
Printing

**Il catalogo è proprietà di Elica spa. Tutti i diritti sono riservati.
È vietata ogni forma di riproduzione anche parziale.**

This catalogue is of exclusive property of Elica spa.
All rights are reserved. Any form of total or partial reproduction of
catalogue is strictly forbidden.

**La stampa tipografica non sempre riproduce fedelmente le tinte
ed i materiali originali.**

The printing process do not always permit a faithful reproducton
of tones and materials of originals.

**Elica si riserva di apportare modifiche ai dati e ai dettagli dei
prodotti presenti su questo catalogo anche senza preavviso.**

Elica may at any time modify the specifications and details of the
products present in the catalogue.

SETTEMBRE 2018
September 2018

Elica
Via Ermanno Casoli, 2
60044 Fabriano AN Italy
T +39 0732 6101
F +39 0732 610249